

STANDARD FEATURES

- Heavy-gauge aluminum construction with continuous welded seams for water tightness and extra strength.

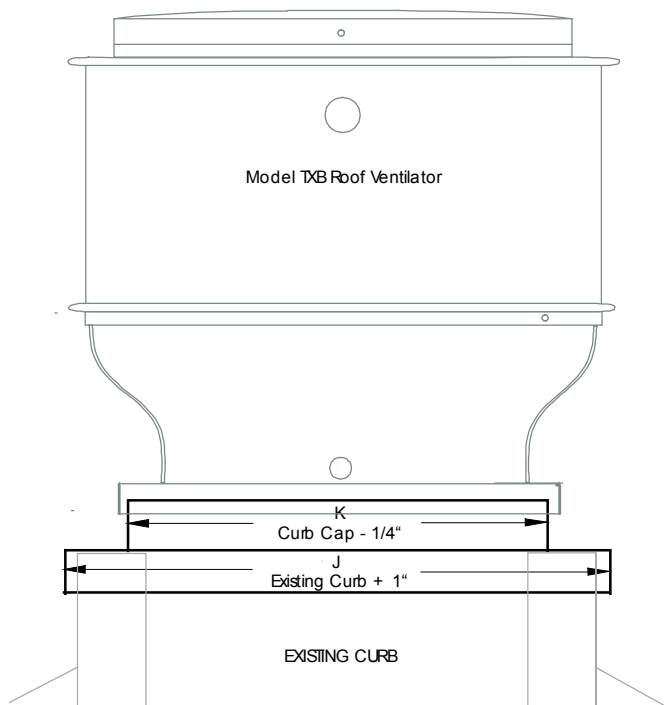

PROJECT	
LOCATION	
ARCHITECT	
ENGINEER	
CONTRACTOR	
SUBMITTED BY	
DATE	P.O. NO.

K - MEASUREMENT
1/4" LESS THAN FAN BASE

J - MEASUREMENT
1" LARGER THAN EXISTING CURB O.D.

SPECIFICATIONS AND DIMENSIONS				
REFERENCE	QUANTITY	K	J	OPTIONS