

FAN SIZE	DAMPER				OPTIONAL MOTOR
	PART NUMBER	MODEL	"A" SQ.	"B" SQ.	
6-10	411012	411	12	-	411611
12-14	411014	411	14	-	411611
15-16	411018	411	18	-	411611
18-22	411024	411	24	-	411611
24-27	411030	411	30	-	411611
30-36	611036	611	36	-	411611
42-48 (UP TO 3HP)	611048	611	48	-	411611
42-48 (5-10HP)	S3GA47RF	S3G	47	49.50	MA220

Model S3G

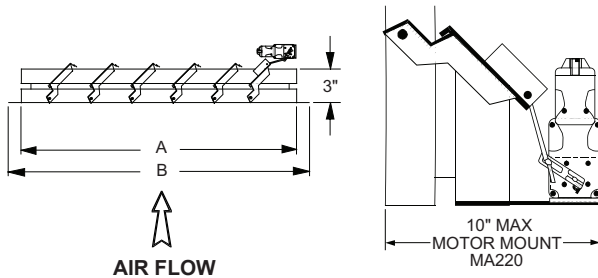
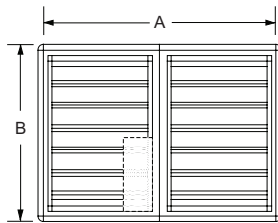

For low velocity (CFM) field adjustment a spring tension may be required to ensure that damper blades open completely.

MODEL S3G STANDARD SPECIFICATIONS:	
Maximum Face Velocity	3000 fpm
Temperature Limits	-40°F to 200°F
Frame	20 gauge galvanized steel
Blades	.025 thick aluminum
Seals	Extruded vinyl mechanically locked into blades
Axles	Stainless steel
Linkage	Stainless steel pins, galvanized steel tie bar
Finish	Mill

CAUTION: Motor kits are not suitable for use in explosive or flammable areas or airflows.
For all supply applications, a motor kit is recommended.

NOTES:

- (1) Do not mount fan less than 12 inches from the shutter.
- (2) Motors available in 24V, 120V, & 240V.
- (3) Dampers shipped in individual cartons.
- (4) Motors and mounting hardware ship separately.
- (5) Multiple section assemblies may require bracing to support the weight of the assembly and to hold against system pressure. **BRACING SUPPLIED BY OTHERS.**

Subject to change unless approved in submittal by JencoFan
S-SeriesDamper_Submittal-v.2_0319

Models 411 & 611

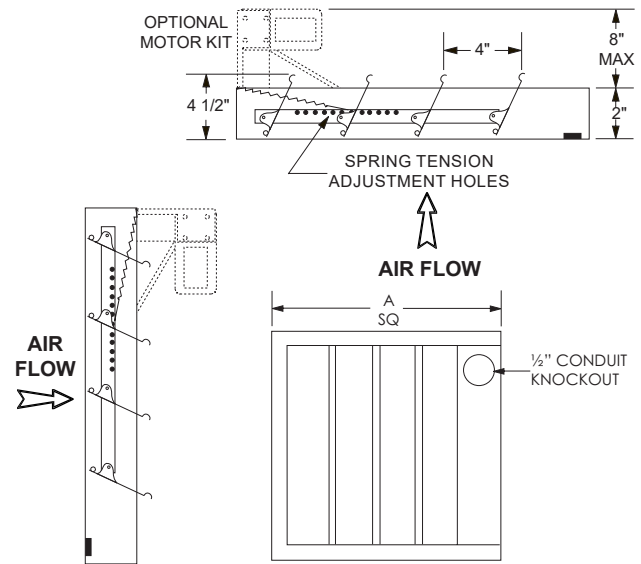

For low velocity (CFM) field adjustment a spring tension may be required to ensure that damper blades open completely.

MODELS 411 & 611 STANDARD SPECIFICATIONS:		
Maximum Face Velocity	2250 fpm	
Frame	Galvanized steel, 2" deep	
Blades	26 gauge mill finish aluminum	
Seals	Felt between adjacent blades	
Axles	Stainless steel rivet at all pivot points	
Counter Balance	Adjustable spring tension	
Finish	Mill	
Max Temp	Damper 250°F	Motor 130°F

CAUTION: Motor kits are not suitable for use in explosive or flammable areas or airflows.

NOTES:

- (1) Units are undersized 1/4" to fit in square ducts.
- (2) Motors available in 24V, 120V, & 240V.
- (3) Do not mount fan less than 1/3 diameter of the fan from the damper.
- (4) Dampers shipped in individual cartons.
- (5) Motor kits ship loose for field installation.