

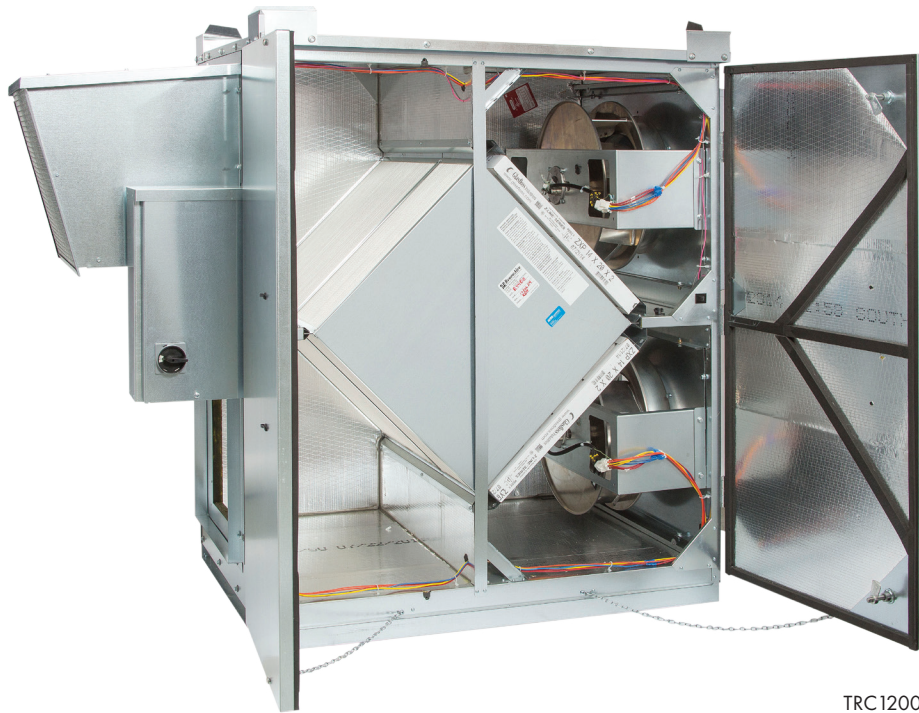

TRC1200RT, TRCe1200RT

ENERGY RECOVERY VENTILATOR

Installation, Operation & Maintenance Manual



TRC1200RT

⚠ WARNING

Standard TRC1200RT with single phase original equipment motors are NOT suitable for use with solid state speed control.

Three phase motors are NOT suitable for use with solid state speed control. If speed control is desired use the VFD option.

Single phase ECM motors are NOT suitable for use with solid state speed control. They already have speed control built into the motor electronics.

⚠ AVERTISSEMENT

Le TRC1200RT avec moteurs d'équipement d'origine monophasés ne convient pas pour une utilisation avec regulateur de vitesse électronique.

Moteurs de trois phase ne convient pas pour utilisation avec regulateur de vitesse électronique. Si la régulation de vitesse est souhaité, utiliser l'option VDF.

Moteurs d'une phase de l'ECM ne conviennent pas pour une utilisation avec regulateur de vitesse électronique. Ils ont déjà le contrôle de vitesse intégré dans le moteur électronique.

⚠ WARNING**ARC FLASH AND ELECTRIC SHOCK HAZARD**

Arc flash and electric shock hazard. Disconnect all electric power supplies, verify with a voltmeter that electric power is off and wear protective equipment per NFPA 70E before working within electric control enclosure. Failure to comply can cause serious injury or death.

Customer must provide earth ground to unit, per NEC, CEC and local codes, as applicable.

Before proceeding with installation, read all instructions, verifying that all the parts are included and check the nameplate to be sure the voltage matches available utility power.

The line side of the disconnect switch contains live high-voltage.

The only way to ensure that there is NO voltage inside the unit is to install and open a remote disconnect switch and verify that power is off with a volt meter. Refer to unit electrical schematic. Follow all local codes.

⚠ WARNING**RISK OF INJURY OR DAMAGE.**

Motor may have a manual reset thermal protector. Disconnect power before servicing or resetting motor thermal protector. Use caution, motor may be hot. Allow the motor to cool before resetting the thermal protector.

If the motor thermal protector tripped, correct the issue that caused the motor to overheat (e.g. over motor rated amperage or locked rotor).

If the motor has a manual reset thermal protector, the red thermal protector reset button is located on the motor body, on or near the lead end of the motor. If the button does not reset, the motor may still be too hot. Allow the motor to fully cool to reset the thermal protector, you should feel or hear a click when the thermal protector resets while pushing the reset button.

⚠ CAUTION**RISK OF ELECTRIC SHOCK OR EQUIPMENT DAMAGE**

Whenever electrical wiring is connected, disconnected or changed, the power supply to the ERV and its controls must be disconnected. Lock and tag the disconnect switch or circuit breaker to prevent accidental reconnection of electric power.

⚠ CAUTION**RISK OF CONTACT WITH HIGH SPEED MOVING PARTS**

Disconnect all local and remote power supplies, verify with a voltmeter that electric power is off and all fan blades have stopped rotating before working on the unit.

Do not operate this unit with any cabinet panels removed.

READ AND SAVE THIS MANUAL/LIRE ET CONSERVER CE MANUEL

NOTICE

This manual contains space for maintaining written records of unit maintenance and/or repairs. See Section 7.7 Maintenance Records. At the time the ERV is commissioned, a maintenance schedule should be developed by the user to incorporate monthly and seasonal maintenance and include start up maintenance tasks as described in this manual.

UNIT INFORMATION

Record information as shown below.

In the unlikely event that factory assistance is ever required, information located on the unit label will be needed.

Locate the S&P USA Ventilation Systems unit label found on the outside of the unit.

NOTE: This information is for purposes of identifying the unit-specific option data from the Option Code.

 NOTE: This page is to be completed by the installing contractor. The completed document is to be turned over to the owner after start up.

- ERV Model:
- TRC1200RTH-230-3P
 - TRC1200RTV-230-3P
 - TRCe1200RTH-230-1P
 - TRCe1200RTV-230-1P

Serial Number:



USA: S&P USA Ventilation Systems, LLC
800.961.7370 | SolerPalau-USA.com
Canada: S&P USA Ventilation Products, Inc.
416.744.1217 | SolerPalauCanada.com

Energy Recovery Ventilator



ETL LISTED
CONFORMS TO
UL STD 1812
CERTIFIED TO
CAN/CSA C22.2
No. 113
Intertek
4000510

Option Code TRC1200RTH-230-3P **Sales Order** 078575

Model/Modele TRC1200RTH-230-3P **Job Order** 46580-0000

Serial Number E24102479CS SCCR KAIC

Power Supply to Unit Alimentation d'énergie a l'unité			Motors protected by IEC Style Motor Starters Les moteurs protégés par des dé moteur de modèle de IEC	
Voltage	Minimum Circuit Amps	Max Overcurrent Protection Device	(QTY) & W/HP	FLA
208-230V	5.0	15	None	-
60 HZ 3-Phase	Amp. Minimales de Circuit	Dispositif de protection maximum contre les surintensités	(QTY) & W/CV	APC
Motors Thermally Protected Moteurs protégé thermiquement			Motors Protected by Variable Frequency Drives Les moteurs protégés par la fréquence variable conduit	
(QTY) & W/HP	FLA	(QTY) & W/HP	FLA	
2@1.0 HP	2.2-2.2	None	-	
(QTY) & W/CV	APC	(QTY) & W/CV	APC	

⚠ WARNING ⚠ AVERTISSEMENT

Danger of electric shock. Always disconnect power source before servicing. Do not install in a cooking area or make line-voltage electrical power connections directly between this unit and any appliance.
Danger of choc électrique. Toujours deconnecter la source d'alimentation avant les réparations. N'installez pas de zone cuisine ou de ligne de tension les connexions d'alimentation électrique directement entre cette unité et tout.

UNIT INFORMATION

UNIT LABEL (TYPICAL)

1.0 OVERVIEW	6	5.5 EXTERNAL CONTROL CONNECTIONS	17
1.1 DESCRIPTION	6	5.5.1 Single 2-Wire Control, Unpowered	17
1.2 AIRFLOW	7	5.5.2 Control Sending 24 VAC "On" Signal	17
2.0 COMPONENT DESCRIPTIONS	7	5.5.3 Control Operating on Unit's 24 VAC Power Supply	17
2.1 CABINET	7	5.5.4 Control on Separate Power Supply	18
2.2 ENTHALPIC CORES	7	5.5.5 Control System Operating Isolation Dampers with End Switches	18
2.3 FAN/MOTOR ASSEMBLIES	8	5.6 QUICK-START FOR TESTING CORRECT 3PH WIRING	18
2.4 E-BOX	8	5.7 FIELD CONVERSION OF OPENINGS	18
2.5 FILTERS	9	5.7.1 To Field Convert the Inlet Opening	18
2.6 FACTORY INSTALLED OPTIONS	9	5.7.2 To Field Convert the Outlet Opening	19
3.0 SHIPPING/RECEIVING/HANDLING	9	6.0 OPERATION	20
3.1 UNIT WEIGHTS AND DIMENSIONS	9	6.1 PRINCIPLE OF OPERATION	20
3.1.1 Unit Dimensions and Weight	9	6.2 PRE-START UP	20
3.1.2 Maximum Shipping Dimensions and Weight	9	6.2.1 Verify Voltages	20
3.2 RIGGING AND CENTER OF GRAVITY	10	6.2.2 Verify Transformer Wiring	20
3.2.1 TRC1200RT Hoisting Weights and COG	10	6.2.3 Inspect Filters	20
3.3 RECEIVING	10	6.2.4 Inspect Foam Gasketing	20
3.4 STORAGE	10	6.2.5 Inspect Fans	20
4.0 UNIT PLACEMENT	11	6.2.6 Inspect and Clean the Cabinet Interior	20
4.1 BEFORE YOU BEGIN	11	6.2.7 Inspect Ductwork Connections	20
4.2 SERVICE CLEARANCES	11	6.3 UNIT START UP	20
4.3 SOUND ATTENUATION	11	6.3.1 Fixed-Speed Units	20
4.3.1 Outside the Building	11	6.4 MEASURING AIRFLOW	21
4.3.2 At the Curb	12	6.4.1 Filter Pressure Drop	22
4.3.3 Ducts	12	6.5 NORMAL OPERATION	22
4.3.4 Radiated Noise	12	6.6 OPERATION IN EXTREME COLD WEATHER	23
4.3.5 Connecting Horizontal Ducts to Unit	12	7.0 MAINTENANCE	23
5.0 INSTALLATION	12	7.1 MAINTENANCE 24 HRS. AFTER START UP	23
5.1 CURB SPECIFICATIONS	12	7.2 MAINTENANCE 30 DAYS AFTER START UP	23
5.2 DUCTWORK	13	7.3 MAINTENANCE SCHEDULE	23
5.2.1 Inside Ductwork System	13	7.4 FILTERS	24
5.2.2 Duct Insulation	13	7.5 FAN MOTOR	24
5.2.3 Use Dampers to Set and Balance Airflow Rates	13	7.6 ENTHALPIC CORE	24
5.3 ELECTRICAL REQUIREMENTS	13	7.6.1 Enthalpic Core Maintenance	24
5.3.1 Factory-Recommended Electric Service Entry	14	7.6.2 Enthalpic Core Removal	24
5.3.2 Low Voltage Control System	14	7.6.3 Enthalpic Core Replacement	24
5.3.3 How to Reset the 24 VAC Circuit Breaker	15	7.7 MAINTENANCE RECORDS	25
5.3.4 Limits of Power Output	15	7.8 SERVICE PARTS	27
5.4 WIRING SCHEMATICS	16	8.0 TROUBLESHOOTING	27

TABLE OF ILLUSTRATIONS

Figure 1.2.0 TRC1200RT Airflow Orientations	7
Figure 2.4.0 E-Box with Motor Starter	8
Figure 3.2.0 TRC1200RT Weights and COGs	10
Figure 4.2.0 Service Clearances, Top view	11
Figure 5.3.0 E-Box Wiring Entry Points	14
Figure 5.4.0 TRC1200RT Three Phase Unit, Standard.....	16
Figure 5.5.0 A Switch or Non-Powered Control using Unit's 24 VAC Power Supply	17
Figure 5.5.1 24 VAC from an External Source.....	17
Figure 5.5.2 An External Control using Unit's 24 VAC Power Supply	17
Figure 5.7.0 Example of CCnverting Vertical Opening to Horizontal Opening	19
Figure 6.4.0 Pressure Port Locations.....	22
Figure 6.4.1 Initial Pressure Drop of MERV 8 Filters, Supplied with This Unit.....	22
Figure 6.4.2 Initial Pressure Drop of MERV 13 Filters, Available as an Accessory	22
Figure 7.8.0 TRC1200RT Service Parts	26



NOTE: This unit is an energy recovery ventilator, or ERV.

It is commonly referred to throughout this manual as an ERV.

1.0 OVERVIEW

1.1 DESCRIPTION

The TRC1200RT energy recovery ventilator (ERV) is a device for recovering both sensible energy (heat) and latent energy (moisture) from the Exhaust Air from an Occupied Space and injecting those energies into an incoming Outside Airstream. It accomplishes this task by forcing the two airstreams through enthalpic cores, where the energy exchange takes place. The two airstreams pass through the enthalpic cores at right angles and the airstreams never mix together. See Section 2.2 Enthalpic Cores in this manual.

Each ERV has two electric blowers, one for each airstream. Fan speeds can be either single speed, or they can be variable speed, controlled by a factory-installed circuit board or by a building management system (BMS). There are a number of different control devices available to control the operation or speed of the unit fans. For further information on available control accessories, see available supplemental installation and operation manuals.

There are two types of TRC1200 units, one for indoor installations and one for rooftop, or outdoor, installation. This manual is for the TRC1200RT, which is the outdoor unit. For information on the indoor version of this product, see the TRC1200 Installation and Operation Manual.

TRC1200RT units are designed to be installed outdoors, mounted on either a factory-supplied curb or on owner-supplied rails.

These ERVs are commonly installed as part of an air handling system that provides heating and cooling of Supply Air. They can also be installed to operate as stand-alone devices when ducted directly to and from the Occupied Space.

Each unit has an integral 24 VAC power supply that is used internally and can also be used as a power source for other optional control devices.

The TRC1200RT units are low-maintenance, requiring periodic replacement of the air filters and annual vacuuming of the enthalpic cores. See Section 7.0 Unit Maintenance in this manual.

IMPORTANT

It is important to understand and use the equipment airstream terminology as it is used in this manual. The airstreams are defined as:

- ♦ OUTSIDE AIR (OA): Air taken from the external atmosphere and, therefore, not previously circulated through the system.
- ♦ SUPPLY AIR (SA): Air that is downstream of the enthalpic cores and is ready for conditioning or for return to the Occupied Space.
- ♦ RETURN AIR (RA): Air that is returned to the ERV from a conditioned space.
- ♦ EXHAUST AIR (EA): Air that is removed from a heating or cooling appliance or from the Occupied Space and discharged.

1.2 AIRFLOW

There are two different airflow options for the TRC1200RT. They are:

- ♦ TRC1200RTV
- ♦ TRC1200RTH

Each configuration includes attached hoods for the OA and EA airstreams.

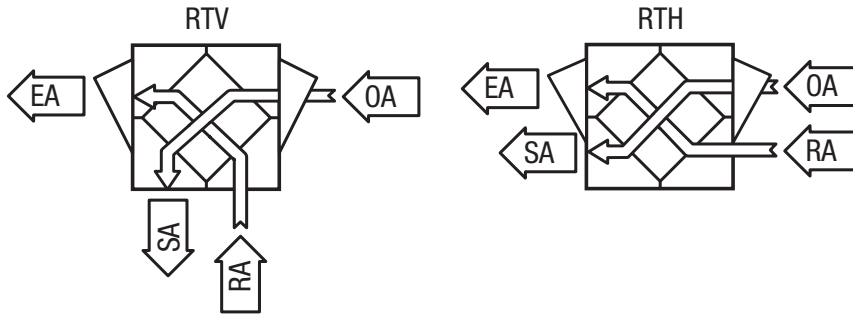

MODEL	DESCRIPTION OF DUCT CONNECTION CONFIGURATION	MOUNTING OPTION
TRC1200RTV	Return Air [RA] enters bottom of unit. Supply Air [SA] exits bottom of unit.	Roof Curb
TRC1200RTH	Return Air [RA] enters side of unit. Supply Air [SA] exits side of unit.	Equipment Rail

FIGURE 1.2.0 TRC1200RT AIRFLOW ORIENTATIONS

2.0 COMPONENT DESCRIPTIONS

2.1 CABINET

The cabinet for the TRC1200RT is made of 20 gauge galvanized steel and has 1" thick high-density, foil-backed insulation on the inside. Units are available in single-wall construction. Doors are hinged and are fitted with stainless steel machine screws through the faces to prevent accidental opening of the doors when the unit is in operation. Doors may be completely removed by removing the hinge pins.

2.2 ENTHALPIC CORES

All TRC1200RT ERVs use a static-plate enthalpic core. The enthalpic cores transfer both latent and sensible energies between the airstreams. Gasketing is pre-installed on the cores and must be positioned to provide a proper air seal. For information on annual maintenance of the cores, see Section 7.0 Maintenance in this manual.

⚠ CAUTION

Low airflow can cause fouling of the enthalpic cores. The ERV must never be operated without clean filters in place and minimum airflow must be greater than 250 CFM per full-sized core.

2.3 FAN/MOTOR ASSEMBLIES

There are two fan and motor assemblies in each ERV.

2.4 E-BOX

Every TRC1200RT is equipped with what is known as an "E-Box." High-voltage supply wiring and low-voltage control wiring is all terminated here. If optional integrated programmable controls are installed, an additional 24 VAC transformer is installed here to power both the controller and its dedicated sensors.

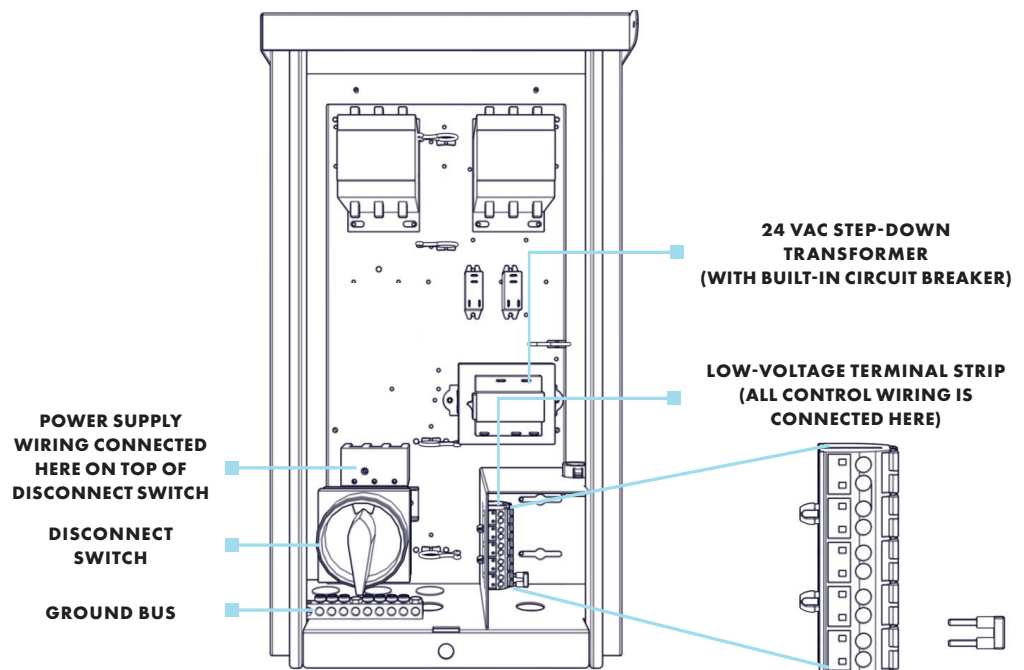

FIGURE 2.4.0 E-BOX WITH MOTOR STARTER

2.5 FILTERS

All TRC1200RT units come equipped with four MERV 8 pleated filters. MERV 13 filters can be ordered as an accessory and are shipped loose.

- (2) 14" x 20" x 2" and (2) 16" x 20" x 2" (nominal) pleated filters. Actual size: 13.5" x 19.5" x 1.75" and 15.5" x 19.5" x 1.75"
- Optionally, (4) 15" x 20" x 2" (nominal) pleated filters. Actual size: 14.5" x 19.5" x 1.75"
- Minimum recommended effectiveness: MERV 6

2.6 FACTORY INSTALLED OPTIONS

All TRC1200RT units can be ordered with factory installed options.

Options will have supplemental manuals shipped with the unit.

For EC Motor option, see *EC Motor Supplemental Manual*.

3.0 SHIPPING/RECEIVING/HANDLING

TRC1200RT units are palletized at the factory and then shipped by common carrier. Upon receipt by the installer, the shipment should be inspected for shipping damage, prior to unloading. Any discovered shipping damage should be immediately reported to the S&P USA Ventilation Systems sales rep and the damage must be recorded on the bill of lading, prior to signing for acceptance of the shipment. The unit can be handled with a fork lift or a crane. Prior to moving the unit, verify that all latches and securing bolts on the cabinet doors are tightly fastened.

If a crane is used for moving the TRC1200RT unit, unscrew the sheet metal plates that hold the unit base to the pallet. Use chain, hooks, and a spreader bar to hoist the unit. Attach the hooks to the four lifting lugs on the roof of the unit. Unit hoisting weights and center of gravity (COG) are detailed in Sections 3.1 and 3.2 in this manual.

Perform a test lift to make sure the unit is being hoisted level and is secure.

Place the TRC1200RT unit on a flat surface where it will be protected from the weather and incidental damage. Do not remove protective coverings from any duct openings and keep the doors secured and tightly closed.

3.1 UNIT WEIGHTS AND DIMENSIONS

3.1.1 Unit Dimensions and Weight:

86" L x 33 1/4" W x 56 1/4" H
394 lbs.

3.1.2 Maximum Shipping Dimensions and Weight:

70" L x 47" W x 83" H
461 lbs.

3.2 RIGGING AND CENTER OF GRAVITY (COG)

3.2.1 TRC1200RT Hoisting Weights and COG

There are lifting lugs at each upper corner of the unit. Use slings or shackles at all four corners. Spreader bars are recommended in order to avoid damage to the unit.

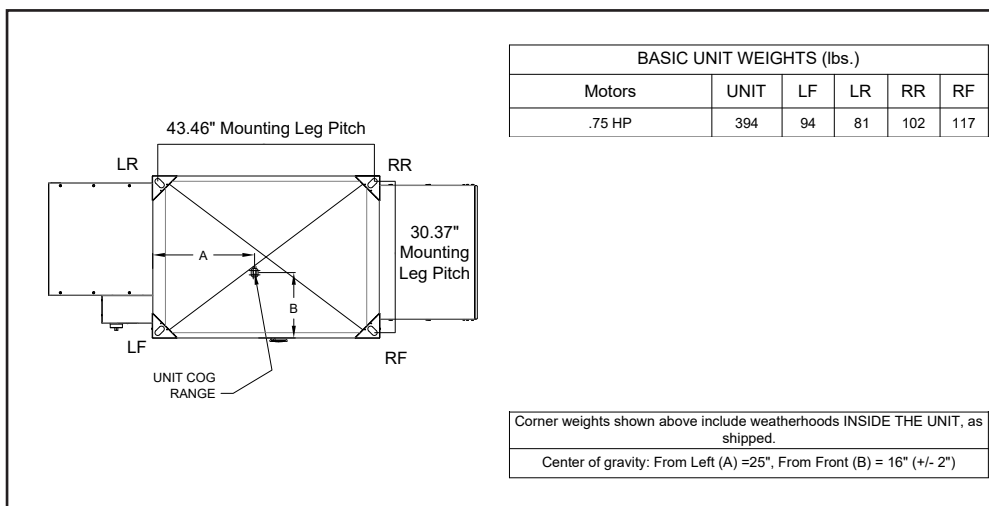

FIGURE 3.2.0 TRC1200RT WEIGHTS AND COGS

3.3 RECEIVING

Upon receipt of the TRC1200RT, inspect the unit for obvious external damage. If damage is observed, take digital pictures and report the damage to your S&P USA Ventilation Systems representative. Note the damage on the carrier's bill of lading. Depending on expected transport and storage conditions, the unit may have only the duct openings covered, it may be stretch-wrapped or it may be crated. Do not unwrap the unit at this time. The unit will normally be moved to its final location while still wrapped and attached to its pallet.

The preferred method of hoisting the TRC1200RT from the carrier truck is by using a construction forklift or a crane.

Once the unit is unwrapped, prevent dirt and debris from entering the cabinet by covering any duct openings that do not have attached dampers. Keep the duct openings covered until it's time to connect ductwork.

3.4 STORAGE

Units that must be stored prior to installation should be left on their pallets and protected from weather and physical damage. Units must be placed on a level surface to prevent warping of the pallet and the TRC1200RT. All access doors must be secured with all available hardware (door latches and securing bolts) and all openings into the cabinet must be sealed to prevent entry of dust, dirt and debris.

4.0 UNIT PLACEMENT

4.1 BEFORE YOU BEGIN

The TRC1200RT is designed for installation outdoors, typically on a rooftop. The preferred mounting method is to place the ERV on an optional manufactured curb, designed for the specific unit. S&P USA Ventilation Systems recommends the use of optional curb clips to provide substantial resistance to wind damage.

For all installations, maintain needed service clearances as shown on the dimensioned drawings located in Section 4.2 of this manual. The curb should be placed on the completed roof decking and located so that the entire perimeter of the curb rests directly on or above structural steel roof supports.

4.2 SERVICE CLEARANCES

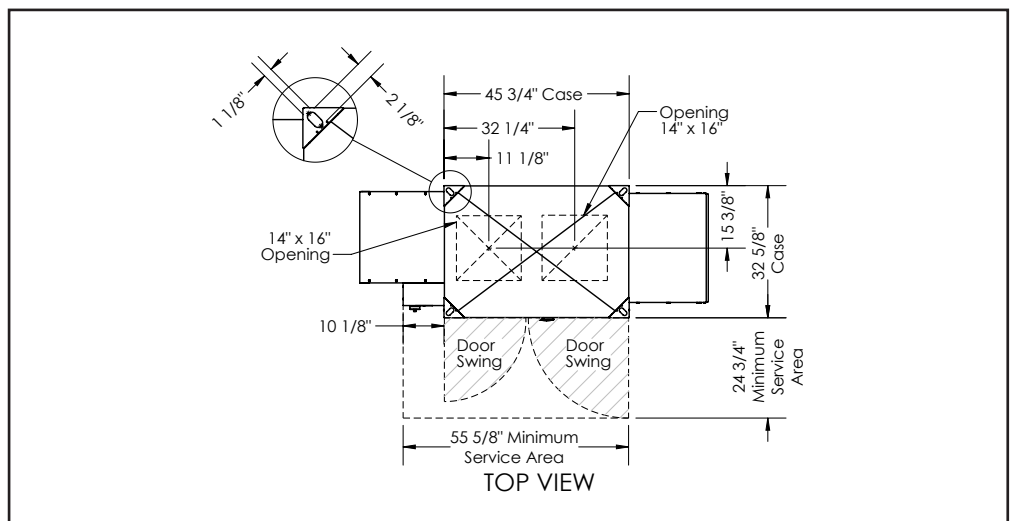

FIGURE 4.2.0 SERVICE CLEARANCES, TOP VIEW

⚠ CAUTION

It is the installer's responsibility to make sure that the screws or bolts used for securing the units are properly selected for the loads and substrates involved. Secure the TRC1200RT so that it cannot fall or tip in the event of accident, structural failure or earthquake. See Rigging Information for unit weight.

S&P USA Ventilation Systems strongly recommends that you secure rooftop units properly to the building structure. Strong winds, tornadoes, and hurricanes can and do displace or remove rooftop equipment from rails or curbs. When this happens, the equipment, adjacent roof structure, and even vehicles parked near the building can be damaged, and rain typically enters the building. The equipment is put out of service and the collateral damage can be very expensive.

4.3 SOUND ATTENUATION

Take these simple steps to attenuate noise from the unit.

4.3.1 Outside the Building

The exhaust hood is the primary source of noise outside the building. When practical, orient the exhaust air hood to point away from houses or public areas.

4.3.2 At the Curb

Cut the holes in the roof deck to fit closely around the duct(s) passing through the roof deck. Seal all gaps around the duct(s) at the roof deck.

4.3.3 Ducts

Make sure the ductwork at the unit outlets is stiff enough to resist the flexure and resulting booming associated with system start up and shut-off, as well as the turbulent flow conditions at the blower outlets.

In general, provide smooth transitions from the ERV's outlets to the duct. The ducts connecting to the outlets should be straight for a sufficient distance, with gradual transitions to the final duct size.

These guidelines are consistent with SMACNA recommended duct layout practices for efficient and quiet air movement. Follow SMACNA guidelines.

4.3.4 Radiated Noise

The TRC1200RT is insulated with high-density fiberglass. This provides significant attenuation of radiated sound from the unit itself.

The outlet ducts can be significant sources of radiated sound as well. The SA duct should be insulated for sound control. This insulation should start at the unit. At a minimum the first 10' of duct should be insulated. All parts of the SA and RA ducts located in a mechanical space with noise-generating equipment also should be insulated for sound control, both to minimize sound radiation out of the SA duct, and also to control sound radiation into both ducts.

4.3.5 Connecting Horizontal Ducts to Unit

Flanged duct connections are provided on the horizontal duct connections of the TRC1200RTH units. These allow for connection of ducts insulated on the inside or the outside, or for installation of lined duct. Please refer to dimension drawings for duct flange sizes.

4.3.2 At the Curb

Cut the holes in the roof deck to fit closely around the duct(s) passing through the roof deck. Seal all gaps around the duct(s) at the roof deck.

4.3.3 Ducts

Make sure the ductwork at the unit outlets is stiff enough to resist the flexure and resulting booming associated with system start up and shut-off, as well as the turbulent flow conditions at the blower outlets.

In general, provide smooth transitions from the ERV's outlets to the duct. The ducts connecting to the outlets should be straight for a sufficient distance, with gradual transitions to the final duct size.

These guidelines are consistent with SMACNA recommended duct layout practices for efficient and quiet air movement. Follow SMACNA guidelines.

4.3.4 Radiated Noise

The TRC1200RT is insulated with high-density fiberglass. This provides significant attenuation of radiated sound from the unit itself.

The outlet ducts can be significant sources of radiated sound as well. The SA duct should be insulated for sound control. This insulation should start at the unit. At a minimum the first 10' of duct should be insulated. All parts of the SA and RA ducts located in a mechanical space with noise-generating equipment also should be insulated for sound control, both to minimize sound radiation out of the SA duct, and also to control sound radiation into both ducts.

4.3.5 Connecting Horizontal Ducts to Unit

Flanged duct connections are provided on the horizontal duct connections of the TRC1200RTH units. These allow for connection of ducts insulated on the inside or the outside, or for installation of lined duct. Please refer to dimension drawings for duct flange sizes.

5.0 INSTALLATION

5.1 CURB SPECIFICATIONS

For all rooftop curbs, the curb is to be placed in a location specified by the architect/engineer as being capable of supporting all known loads. Curbs are to be installed using Industry Best Practices. For installation guidelines, see the current National Roofing Contractors Association (NRCA) manuals.

For metal roofs that are supported by structural steel, the supporting structural steel must be located so that it supports the entire perimeter of the curb. Ideally, the curb will be placed directly on the structural steel and the metal roof decking is to be fitted around the curb. It is acceptable to place the metal roof decking on the structural steel and then place the curb on top of the metal roof decking. When this is done, wood fillers must be installed in the decking corrugations to provide complete support for the curb bottom flanges. In all cases, all four bottom flanges of the curb must bear directly on or over the structural steel roof supports.

For pre-stressed concrete roofs, the location of the curb must be approved by an engineer as being capable of supporting all known loads.

Curbs are shipped knocked-down and include all necessary assembly hardware, to include foam gasketing tape. To assemble the curb, assemble the four sides of the curb with the provided hardware, but leave the hardware loose. When the four curb sides are assembled, install the provided mid-rails within the curb walls and then tighten all fasteners. See Dimension Drawings for curb dimensions.

Curb clips are available as an optional accessory and can be installed as needed. Install foam gasketing (provided) on all bearing surfaces on the curb.

Optional installation of owner-provided rails (TRC1200RTH only):

S&P USA Ventilation Systems recommends that all TRC1200RT units be installed on a S&P USA Ventilation Systems-supplied curb that is manufactured to match individual units. The only unit that may be installed on owner-supplied mounting rails is the TRC1200RTH. When owner-supplied mounting rails are used, S&P USA Ventilation Systems cannot provide installation instructions and it is the responsibility of the installer to verify compliance with all local building codes and structural integrity of the installation. Any such installation on owner-provided rails must be reviewed and approved by an engineer.

5.2 DUCTWORK

Basic Requirements:

Always connect an RA and an SA duct to each rooftop unit.

- With rooftop units, the RA and SA ducts cannot be interchanged.
- With RTV units, both ducts are inside the building. With RTH units, both ducts are outside and must be weatherized.
- Any weatherized duct must be thermally insulated to prevent condensation on the inside or outside of the duct. The duct lining must be vapor-sealed, and the duct exterior must be rain tight. Duct(s) connected to the bottom of the TRC1200RT are generally installed at this time. Install (2) ducts with TRC1200RTV.

Drop duct(s) into openings in top of roof curb.

Install appropriate gasket on top of roof curb and edges of ducts.

5.2.1 Inside Ductwork System

Follow engineer’s ductwork design; ductwork should be designed by an engineer to allow the unit to provide the required airflow.

5.2.2 Duct Insulation

If the inside ducts run through unconditioned spaces, they must be insulated, with a sealed vapor barrier on both inside and outside of insulation.

5.2.3 Use Dampers to Set and Balance Airflow Rates

In most applications, the airflow rate for both the Supply Air and the Exhaust Air should be roughly equal (or “balanced”) for best performance of the TRC1200RT unit. See unit specification sheet for CFM/ESP curves for available horsepower motors.

 NOTE: Ducts inside a building that are connected to the outside must be insulated with a sealed vapor barrier on both the inside and the outside of the insulation.

⚠ CAUTION
Tape both inner and outer vapor barriers of insulated duct to collars on duct adapters. This is critical to prevent migration of moisture into insulation. Build-up of moisture can result in failure of the duct system and/or frost in the insulation. Make sure any tears in the inner and outer vapor barriers are sealed.

5.3 ELECTRICAL REQUIREMENTS

Electrical options and ratings are identified on the unit label (located near electrical box). Find the complete Unit Model Number in the lower left corner of the unit label.

⚠ CAUTION
Before bringing power to the unit check unit nameplate to confirm it matches the voltage and phase of the power you are supplying. Remember that your field connections need to be accessible for inspection.

 NOTE: If your unit is equipped with EC Motors, please refer to “EC Motor Supplemental Manual” for more detail.

Use conduit, strain reliefs, etc. as required by code to secure the field wiring.

5.3.1 Factory-Recommended Electric Service Entry

Knockouts are provided in the bottom of the E-box for entry of high-voltage power supply wiring. Install the wiring in accordance with local codes and provide strain relief at the E-box opening. Wiring is then terminated on the top of the disconnect switch.

Low-voltage control wiring is to enter the E-box through the knockout in the bottom of the E-box. Provide strain relief as needed.

High-voltage supply wiring is to be connected on the top side of the disconnect switch. See image below.

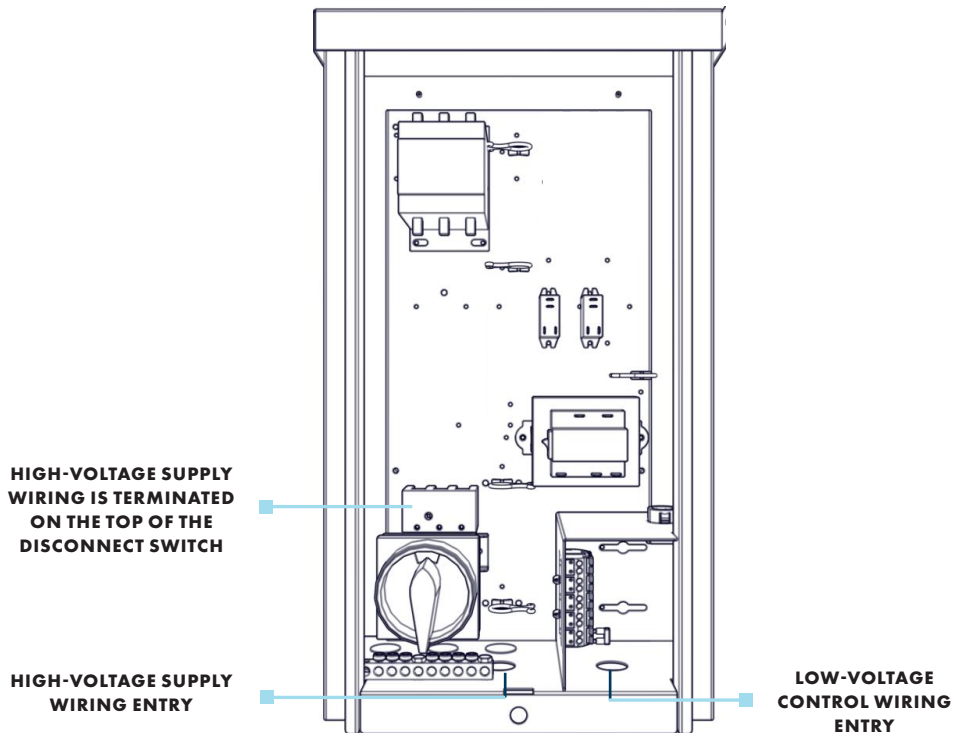

FIGURE 5.3.0 E-BOX WIRING ENTRY POINTS

5.3.2 Low Voltage Control System

This ERV is provided with a Class II 24 VAC power supply system that operates the unit's contactor(s) for TRC1200RT. The ERV's 24 VAC Power Supply can also be used to power the externally-installed controls system: up to 8 VA of power is available.

The unit's power supply system includes isolation relay(s) so you can use external controls whose contact ratings are as low as 50 mA (1.2 VA). Also, it is possible to operate the isolation relays with 24 VAC power from an external source (with proper wiring connections).

A built-in circuit-breaker prevents damage to the transformer and other low-voltage components in the event of a short-circuit or overload. In extreme cases, the transformer itself is designed to fail safely.

Specifications:

- ♦ Nominal Output Voltage under load: 24 VAC
- ♦ Typical Output Voltage at no load: 29–31 V
- ♦ Minimum contact rating for connected control device: 50 mA (1.2 VA)
- ♦ Circuit Breaker Trip Point: 3 A

⚠ CAUTION

1. Connect only to components intended for use with 24 VAC power.
2. Do not undersize the low-voltage wires connected to this device. Observe the wire length and gauge limits indicated in this manual.
3. Do not overload this unit's 24 VAC power supply system. Confirm that the power requirements of devices you connect to this power supply system do not exceed 8 VA in total.
4. If an external source of 24 VAC power is used to control the unit, consult the wiring schematics and connect the external power only to the specified terminals in order to avoid damaging the unit or external controls. Connect only CLASS II power to the control terminals of this unit.
5. Unit is not equipped to receive analog signals (such as 1–10 vdc or 4–20 mA).

NOTICE

If primary-side voltage is 230 VAC, move black primary-side lead from transformer's "208 V" terminal to the transformer's terminal marked "240 V" ("230 V" in some units). Do not move the black primary-side lead that is connected to the transformer's "COM" terminal.

5.3.3 How to Reset the 24 VAC Circuit Breaker

If the transformer is subjected to an excessive load or a short circuit, the circuit breaker will trip to prevent the failure of the transformer. When it trips the circuit breaker's button pops up. Shut off the primary-side power to the unit, and remove the excessive load or the short. The circuit breaker can be reset about fifteen seconds after it trips by pressing in the button.

5.3.4 Limits of Power Output

If limits on wire gauge and length are observed, you may connect control devices that draw up to 8 VA to the blue and red wires. More than one device can be connected as long as total steady-state load does not exceed 8 VA.

⚠ CAUTION

Be careful if the external control system provides 24 VAC power at its control output: make sure blue and red leads are separately capped and not connected to any other wires.

Wire Gauge	#22	#20	#18	#16	#14	#12
Circuit Length	100'	150'	250'	400'	700'	1000'

"Circuit Length" is distance from ERV to Control Device.

Observe these limits to wire length and gauge in order to ensure reliable operation of the control system.

5.4 WIRING SCHEMATICS

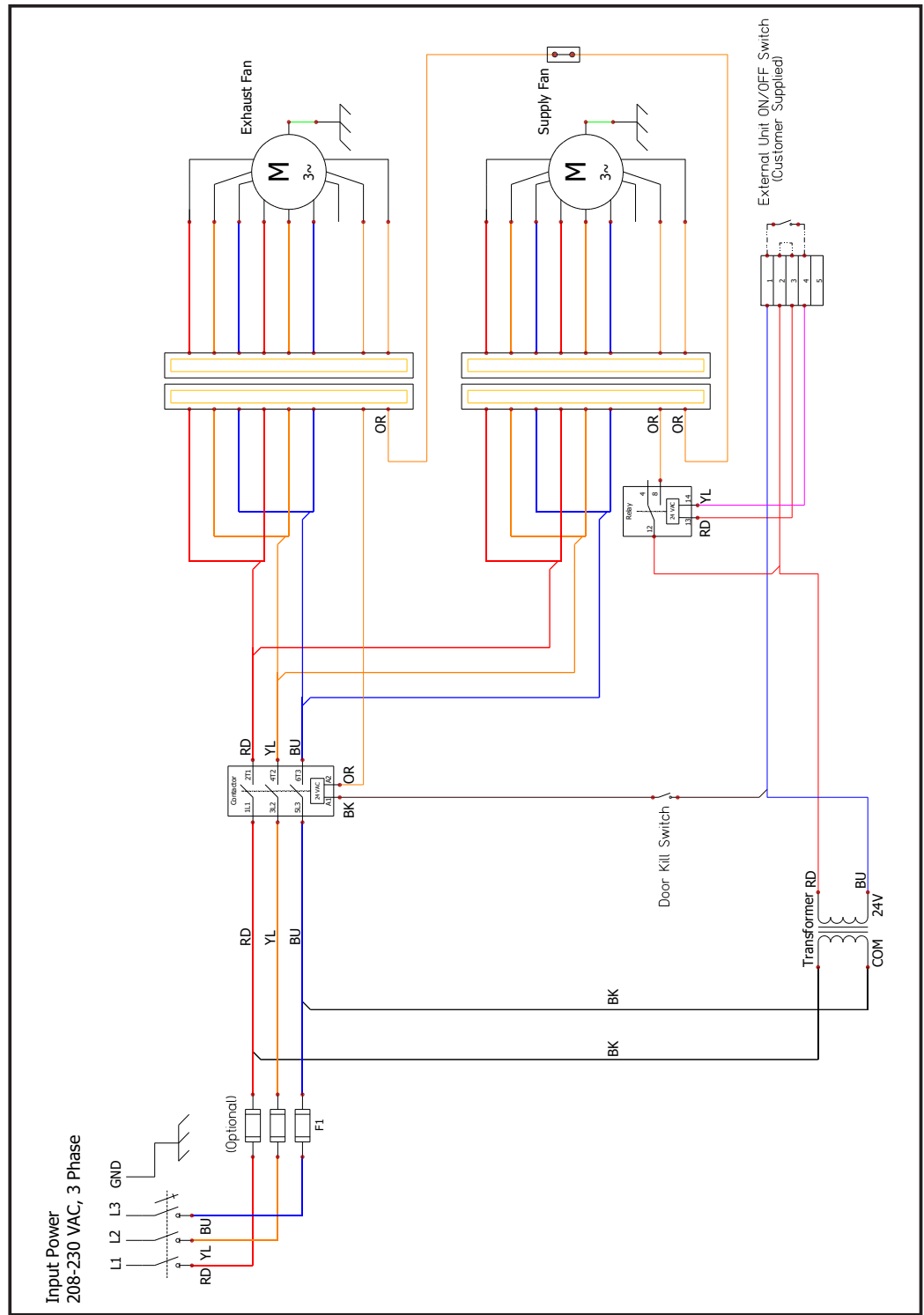

FIGURE 5.4.0 TRC1200RT THREE PHASE UNIT, STANDARD

5.5 EXTERNAL CONTROL CONNECTIONS

5.5.1 Single 2-Wire Control, Unpowered

Use the schematic shown in Figure 5.5.0 if the control requires no power to operate and acts like a simple on/off switch. The control must not supply any power to the ERV unit.

- Install jumper (provided) between terminals 2 and 3.
- Connect the control's contacts to terminals 1 and 4 to operate the ERV's isolation relay.

Control on separate Power Supply, no power present at Control Output:

Wire as shown for the Single 2-wire control.

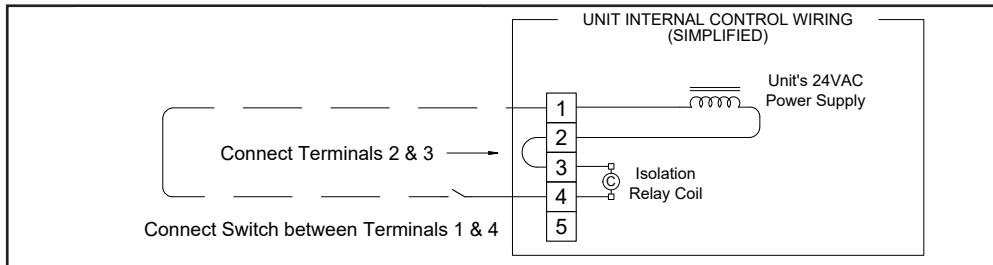

FIGURE 5.5.0 A SWITCH OR NON-POWERED CONTROL USING UNIT'S 24 VAC POWER SUPPLY

5.5.2 Control Sending 24 VAC "On" Signal

Use the schematic shown in Figure 5.5.1 if a 24 VAC "On" signal is to be sent from an external power source to the ERV.

- Make sure jumper is NOT installed between Terminals 2 and 3.

Now you safely can apply 24 VAC to the Terminals 3 and 4 to operate the ERV's isolation relay.

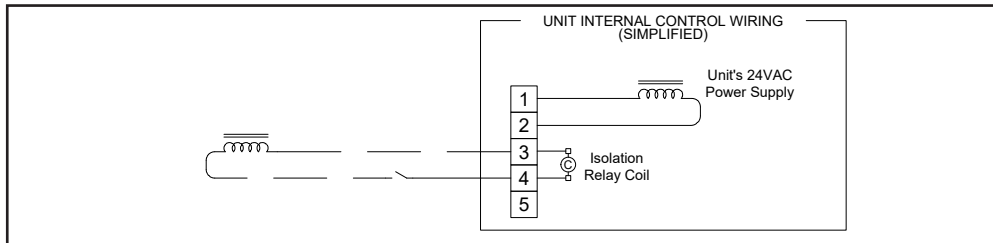

FIGURE 5.5.1 24 VAC FROM AN EXTERNAL SOURCE

5.5.3 Control Operating on Unit's 24 VAC Power Supply

Use the schematic shown in Figure 5.5.4 if controls are operating on unit's 24 VAC power supply.

- 24 VAC power is available at the Terminals 1 and 2.
- Install jumper (provided) between terminals 2 and 3.
- Connect the switched output of the Control to Terminal 4 to operate the ERV's isolation relay.

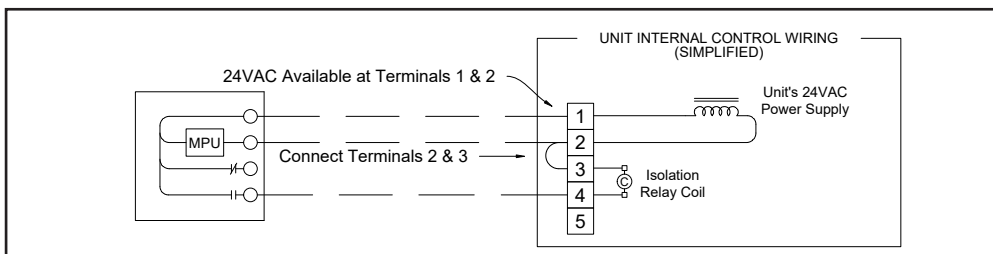

FIGURE 5.5.2 AN EXTERNAL CONTROL USING UNIT'S 24 VAC POWER SUPPLY

NOTE: The simplified schematics below show only the relevant portions of the low-voltage control circuit in the ERV unit and representational external control approaches. See the complete unit schematics on the previous page.

CAUTION
Make sure the control provides no voltage or current at its output terminals.

CAUTION
Supply only 24 VAC (not VDC) from a Class II Power Source.

CAUTION
External control system should not draw more than 8 VA.

5.5.4 Control on Separate Power Supply

Use this schematic only if no power is present at the controls output terminals.

- ♦ Install jumper at terminals 2 and 3.
- ♦ Connect the Control's Normally Open (N.O.) contacts to terminals 1 and 4.

See Wiring Schematics.

5.5.5 Control System Operating Isolation Dampers with End Switches

Use Isolation Dampers with electrically separate end switches. The end switches are used to separately control the ERV unit's Isolation Relay. Also, it is necessary to wire the end switches for each isolation damper in series, to ensure that each damper is open before the unit blowers start-up.

Because the ERV's Motor Starter will only be operating once the Dampers are open, the power draw of the Damper Actuators is allowed to be as much as 35 VA while opening (including power draw of the external control system, if any). However, the power draw of the fully-opened (stalled) Actuators (and external control system if any) must be less than 8 VA.



NOTE: Any changes to unit low-voltage wiring should be made with the disconnect switch in the OFF position.

5.6 QUICK-START FOR TESTING CORRECT 3PH WIRING

All units that run on 3 phase power should be test-run immediately after high voltage wiring connections are made. This will verify that the three phases are properly connected.

For purposes of testing correct phase connections, the internal 24 VAC power supply will be used to power-up the fans and all external control devices will be disabled, when applicable.



NOTE: When installing temporary jumpers on the low-voltage terminal strip, use 18 gauge or larger wire.

5.7 FIELD CONVERSION OF OPENINGS

The TRC1200RT is designed to allow field conversion of the Return Air (RA) and Supply Air (SA) unit openings. This means the RA motorized impeller subassembly can be moved to an adjacent side or base of the unit if that opening is preferred. The SA outlet opening can also be moved to an adjacent wall or base.

Before you start, plan the duct work layout. Determine which openings are to be converted.

- ♦ Turn off the disconnect switch on the unit. Make sure electrical power is shut off to the unit and disconnect switch.
- ♦ Open the access doors to the unit.
- ♦ Remove the core strap, filters, and energy exchanger cores from the unit.

5.7.1 To Field Convert the Inlet Opening

1. Disconnect motor harness connector by the motor. Move the wire harness out of the way if necessary.
2. Support the impeller subassembly. Remove the eight ¼-20 bolts retaining the impeller subassembly plate to the side rails and front and back tabs.
3. Lift the entire impeller subassembly out of the unit and set aside. Leave the rails in the unit.
4. Remove the patch pan from the desired opening.
5. Using the exposed sheet metal cutout, cut the insulation from the desired opening.
6. Seal the edges of the cut insulation to prevent erosion of the insulation edges and having debris in the airstream.
7. Install the patch pan over the undesired opening.
8. Install the insulation in the undesired opening. Seal the insulation.
9. At this point, if the Supply Air (SA) outlet opening is to be converted, you will want to address it before proceeding with the RA inlet opening.
10. After converting the SA outlet opening proceed with the RA inlet opening.



NOTE: The RA patch pan may be on the underside of the base pan. Safely access the underside of the unit to remove the patch pan.

11. Install the impeller subassembly into the new inlet opening and fasten with eight ¼-20 bolts to retain to the side rails and front and back tabs. Make sure the motor harness connector is towards the front of the unit.
12. Connect the motor harness.
13. Tidy up any wire harnesses that were moved making sure motor wires are taut and away from the impeller blades.

5.7.2 To Field Convert the Outlet Opening

1. Remove the patch pan from the desired opening.
2. Using the exposed sheet metal cutout, cut the insulation from the desired opening.
3. Seal the edges of the cut insulation to prevent erosion of the insulation edges and having debris in the airstream.
4. Install the patch pan over the undesired opening.
5. Install the insulation in the undesired opening. Seal the insulation.
6. If the RA inlet opening is being converted return to Step 10 in the "To Field Convert Return Air (RA) Inlet Opening" instructions above.

 NOTE: The SA patch pan may be on the underside of the base pan. Safely access the underside of the unit to remove the patch pan.

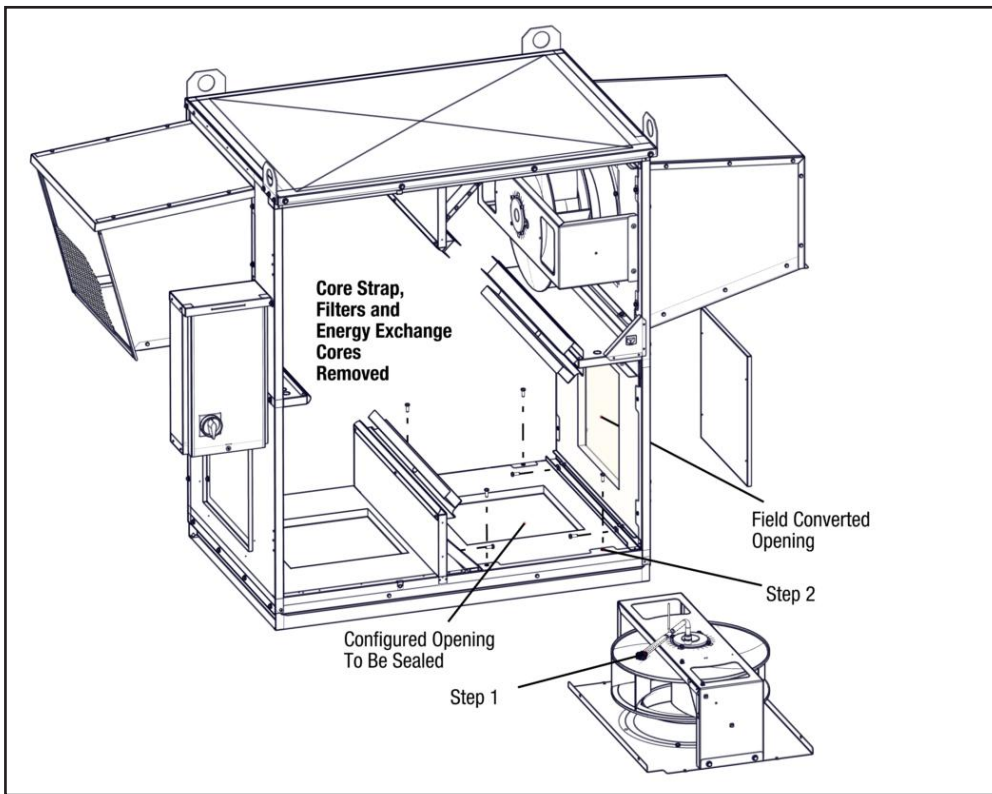

FIGURE 5.7.0 EXAMPLE OF CONVERTING VERTICAL OPENING TO HORIZONTAL OPENING

After completion of the field conversion:

- ♦ Clean out the interior of the unit to remove any debris.
- ♦ Install energy exchanger cores, filters, and core strap.

6.0 OPERATION

6.1 PRINCIPLE OF OPERATION

The TRC1200RT has one basic purpose: to exhaust air from a structure and bring in fresh air from outside, while transferring heating or cooling energy from the exhaust air to the supply air.

The TRC1200RT is a very simple device, and will accomplish this purpose as long as the blower is able to move air through the enthalpic core.

6.2 PRE-START UP

6.2.1 Verify Voltages

Using a voltmeter, test the input voltages as supplied to the disconnect switch. Refer to Digit 13 of the unit Configuration Code to find the rated voltage. The supplied voltage must be within +/- 10% of the rated voltage.

6.2.2 Verify Transformer Wiring

Units with 230 VAC power source are shipped with the transformer wired for 208 VAC. If the unit is receiving 230 VAC, make sure the black primary-side wire on the transformer's 208 V terminal has been moved to the 230 V terminal.

6.2.3 Inspect Filters

Clean filters must be installed prior to fan start up.

6.2.4 Inspect Foam Gasketing

Inspect the gasketing to make sure there are no gaps allowing air movement around the cores or filters.

6.2.5 Inspect Fans

Prior to start-up and connecting ductwork, when the TRC1200 unit and fans are installed in the desired orientation, check the gap between wheel and inlet ring—it should be consistent all the way around. Spin the blower wheel vigorously to confirm it does not rub. If the inlet ring needs re-adjusting, loosen the 4 bolts and nuts holding the inlet ring and adjust it such that there is a consistent gap between the wheel and inlet ring.

6.2.6 Inspect and Clean the Cabinet Interior

During the construction and installation phases of a project, dust, dirt and debris will often accumulate inside a unit. Thoroughly clean the inside of the unit by vacuuming and/or wiping metal surfaces with a damp rag.

6.2.7 Inspect Ductwork Connections

Ducts attached to the ERV must be firmly attached, sealed and supported in accordance with installation instructions and SMACNA guidelines.

6.3 UNIT START UP

6.3.1 Fixed-Speed Units

Most fixed-speed units do not have any external controlling signals and only require turning on the disconnect switch, located on the E-Box. When the disconnect switch is turned ON, any dampers will first move into their correct operating positions and then power is supplied to the motor contactors, causing the fans to run.

Some fixed-speed units are wired to receive an actuating signal from an external source. If there is an external actuating signal source, verify the type of signal and that it is wired according to the low-voltage wiring diagrams found in Section 5.5 of this manual. Turn on the disconnect switch and then turn ON the actuating device. After any dampers have moved into their correct positions, power is then applied to the motor contactors and the fans will begin running.

IMPORTANT

It is important to balance the airflows after the unit is operational and all ductwork has been installed. Balancing the airflows is typically required by state and/or local codes, and is often specified by the HVAC design engineer.

Optimum efficiency of the enthalpic cores is achieved when the airstreams are properly balanced.

 NOTE: ERV airflows are to be balanced after all ductwork is installed. Balancing of airflows is typically required by local or state building codes or by the HVAC design engineer.

 NOTE: The tubing should extend in the pressure port approx. 1".

 NOTE: Make sure clean filters are installed before balancing airflow. Dirty or clogged filters reduce airflow through the unit.

6.4 MEASURING AIRFLOW

Airflow should be occurring in both airstreams. Sometimes the easiest place to confirm that air is moving is at the weatherhoods.

If exact airflow is critical, it may be desirable to permanently install flow measuring stations and manometers in the ductwork connected to the unit. These also can be used to determine when filters should be cleaned or changed.

Equipment Required

- ◆ A magnehelic gauge or other device capable of measuring 0–1.5 in. water of differential pressure.
- ◆ 2 pieces of natural rubber latex tubing, 1/8" ID, 1/16" Wall works the best.

Procedure: The individual differential static pressures (DSP) can be measured using the installed pressure ports located in the front of the units core access doors.

- ◆ To read SCFM of Supply Air (SA) install the "high" pressure side (+) of your measuring device to the Outside Air (OA) port and the "low" pressure side (-) to the Supply Air (SA) port.
- ◆ To read SCFM of Return Air (RA) install the "high" pressure side (+) of your measuring device to the Return Air (RA) port and the "low" pressure side (-) to the Exhaust Air (EA) port.
- ◆ Use the reading displayed on your measurement device to cross reference the CFM output using the conversion chart.

 NOTE: These ports have been carefully located on the unit as to give you the most accurate airflow measurement. Do not relocate pressure ports.

CAUTION
The proper operating airflow range for this model is 375–1400 CFM.

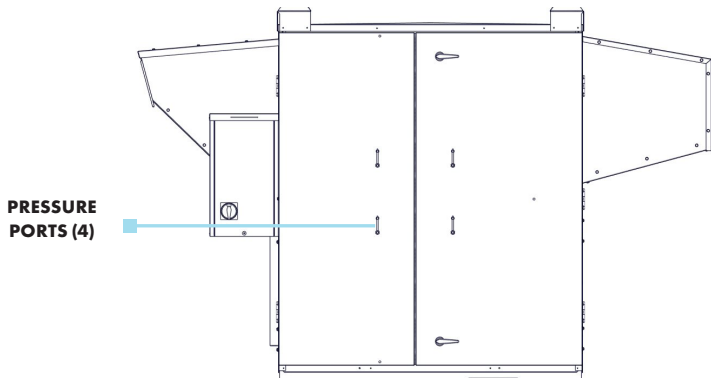



FIGURE 6.4.0 PRESSURE PORT LOCATIONS

DIFFERENTIAL STATIC ACROSS CORE DSP vs. CFM																		
TRC1200RT	DP (H ₂ O)	DSP	0.10	0.15	0.20	0.25	0.30	0.35	0.40	0.45	0.50	0.55	0.60	0.65	0.70	0.75	0.80	0.85
	Supply Air (SA)	CFM	335	450	555	650	745	835	920	1005	1085	1165	1240	1315	1385	1460	1530	-
	Return Air (RA)	CFM	-	-	-	-	-	300	380	475	575	685	805	935	1070	1220	1375	1535

 NOTE: Clean filter pressure drop is included in unit airflow performance tables.

6.4.1 Filter Pressure Drop

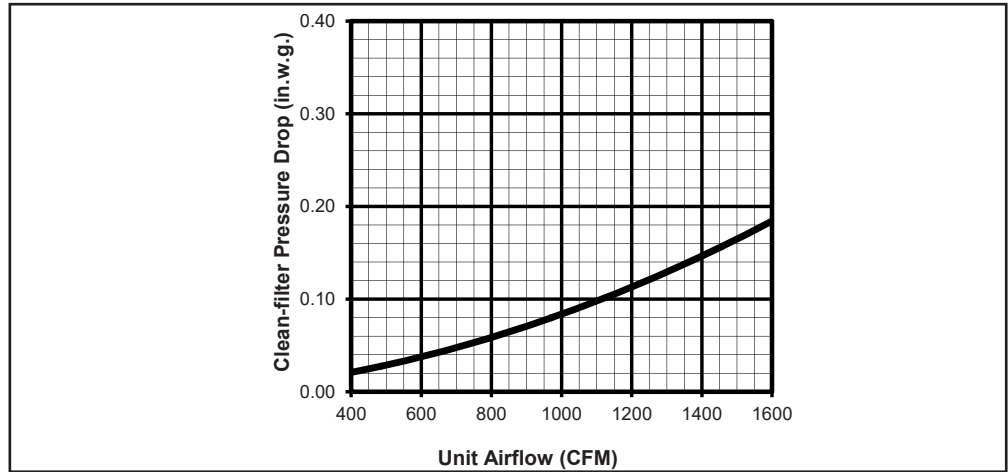

FIGURE 6.4.1 INITIAL PRESSURE DROP OF MERV 8 FILTERS, SUPPLIED WITH THIS UNIT

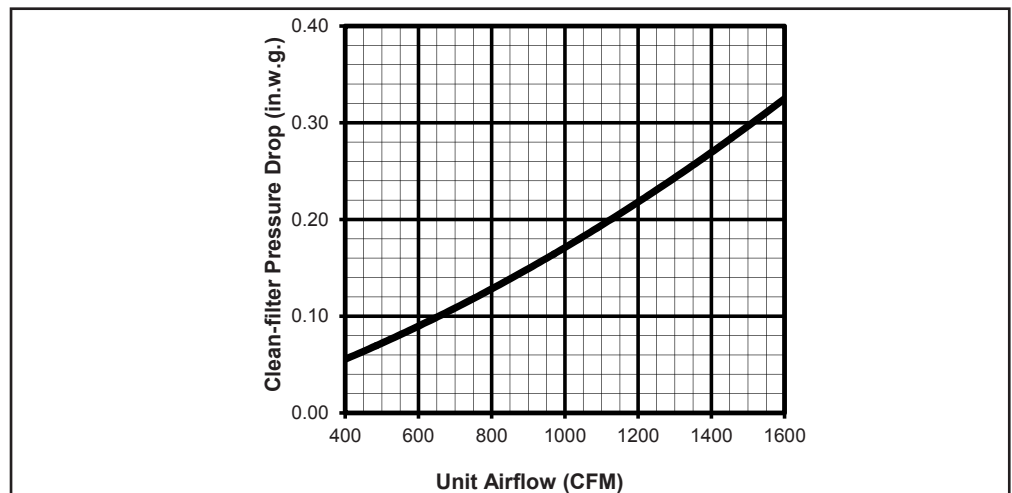

FIGURE 6.4.2 INITIAL PRESSURE DROP OF MERV 13 FILTERS, AVAILABLE AS AN ACCESSORY

6.5 NORMAL OPERATION

A wide variety of control schemes may be selected by the engineer, installer, or owner to meet the ventilation needs of the facility. These may include timer clocks, occupancy sensors, dehumidistats (for cool-weather operation), carbon dioxide sensors, and others. DDC systems may also control the unit. Most control schemes will operate the unit only when needed.

Continuous operation is acceptable in virtually all conditions. Unit will not be damaged by continuous operation as long as airflow occurs. Blower motors may overheat if filters become completely blocked due to lack of maintenance. Motors are thermally protected. With continuous operation, some external frosting may occur in very cold weather (see Section 6.6).

6.6 OPERATION IN EXTREME COLD WEATHER

TRC1200RT units are capable of operating without internal frosting at temperatures down to -10°F, with indoor humidity below 40%. The units can operate under more severe conditions occasionally with little or no impact on their performance. At lower humidities, they can operate at still lower outside temperatures without freezing the enthalpic cores.

Some condensation or even frost may form on the outside of the unit or drip off the cabinet during very cold conditions, especially if the unit runs continuously. Exterior condensation during extreme cold conditions can be reduced or prevented by periodically cycling the unit OFF for several minutes to allow the cabinet to warm up.

7.0 MAINTENANCE

S&P USA Ventilation Systems ERVs are built to operate with minimal maintenance. After unit commissioning, the primary areas of attention are the air filters and annual vacuuming of the enthalpic cores.

7.1 MAINTENANCE 24 HOURS AFTER START UP

24 hours after unit start up:

- ♦ In new installations, check the air filters since they will often collect dust, dirt and debris at time of start up.

7.2 MAINTENANCE 30 DAYS AFTER START UP

After 30 days of operation:

- ♦ Tighten all electrical connections.
- ♦ Check the air filters as part of the normal monthly maintenance.

7.3 MAINTENANCE SCHEDULE

Experience on the part of the service person is the most important issue in establishing a maintenance schedule. There will be times of the year when frequent inspection of the filters will be required, such as spring and summer when there may be pollen, dust, dirt or debris from budding trees and bushes that can clog the filters. Also see Section 7.7 Maintenance Records in this manual.

⚠ WARNING

Danger of injury if unit starts unexpectedly. Switch power off at service disconnect. Lock-out/tag-out the disconnect.

⚠ WARNING

Danger of electrical shock when servicing an installed unit.

ALWAYS DISCONNECT POWER SOURCE BEFORE SERVICING! More than one disconnect switch may be required.

Proper wiring size selection and wiring installation are the responsibility of the electrical contractor.

⚠ WARNING

RISK OF INJURY OR DAMAGE.

Motor may have a manual reset thermal protector. Disconnect power before servicing or resetting motor thermal protector. Use caution, motor may be hot. Allow the motor to cool before resetting the thermal protector.

If the motor thermal protector tripped, correct the issue that caused the motor to overheat (e.g. over motor rated amperage or locked rotor).

If the motor has a manual reset thermal protector, the red thermal protector reset button is located on the motor body, on or near the lead end of the motor. If the button does not reset, the motor may still be too hot. Allow the motor to fully cool to reset the thermal protector, you should feel or hear a click when the thermal protector resets while pushing the reset button.

7.4 FILTERS

Inspection and replacement of air filters is the most frequent maintenance issue. For units that do not have filter air pressure differential sensors, filters must be visually inspected monthly, as a minimum. If a filter looks discolored or dirty, REPLACE IT! When installing new filters, DO NOT USE filter sprays. Residue from the filter spray could migrate to the enthalpic core media and damage the cores.

For units that have filter air pressure differential sensors, a dirty filter alarm will occur on the connected alarm or control device.

Filter cleanliness and replacement is the most important and frequent maintenance issue. Dirty filters will cause an immediate reduction in operating efficiency of the ERV. Normally, filters should be inspected and changed when they are dirty. Paper filters are not to be cleaned, they are to be replaced.

In general, if a filter looks dirty, replace it. The best indication of dirty filters is to check the pressure drop across the filter banks with an optional filter monitor. If it is not possible to check the pressure drop, the rule of thumb would be to change the filters every two months.

7.5 FAN MOTOR

The motor needs no lubrication. If necessary vacuum clean the blower wheels at the same time you clean the face of the energy exchange element (annually).

7.6 ENTHALPIC CORE

⚠ CAUTION
RISK OF DAMAGE TO ENTHALPIC CORES
Whenever working within the ERV cabinet, protect the enthalpic cores from accidental damage. The core media is subject to damage from dropped tools or other foreign objects

7.6.1 Enthalpic Core Maintenance

The enthalpic core media is a fibrous material that must be kept clean at all times. As a minimum, cores should be cleaned once per year.

- ♦ DO NOT WASH OR ALLOW THE ENTHALPIC CORES TO GET WET.
- ♦ DO NOT EXPOSE THE ENTHALPIC CORES TO HIGH HEAT OR FLAMES.
- ♦ DO NOT DIRECT COMPRESSED AIR AT THE CORE MEDIA.
- ♦ DO NOT REMOVE THE ENTHALPIC CORES FROM THE ERV UNLESS NECESSARY.
- ♦ USE CAUTION WHEN WORKING AROUND THE ENTHALPIC CORES. DO NOT DROP TOOLS OR OTHER OBJECTS ON THE CORES, DO NOT BUMP OR TWIST THE CORES.

To access enthalpic cores for cleaning, remove the air filters.

To clean enthalpic cores, all exposed surfaces must be vacuumed with an attachment having long, soft bristles. The greatest buildup of dirt and dust will normally be on the leading 1–2 inches of the inlet side (closest to the air filters).

7.6.2 Enthalpic Core Removal

Before removing enthalpic cores, switch the main disconnect to OFF. Open the door to the energy recovery module and simply pull the core straight out of its guides.

7.6.3 Enthalpic Core Replacement

Cores have foam gasketing on one end of each core. The core should be reinstalled so that the foam gasketing is toward the back of the ERV and the core label is facing toward the front. See Figure 7.8.0.



7.7 MAINTENANCE RECORDS

MAINTENANCE LOG					
ENTER DATES OF SERVICE					
OA FILTER CHANGE	RA FILTER CHANGE	INSPECTION/ CLEANING	CLEAN CORE	CLEAN BLOWERS	INITIALS

7.8 SERVICE PARTS

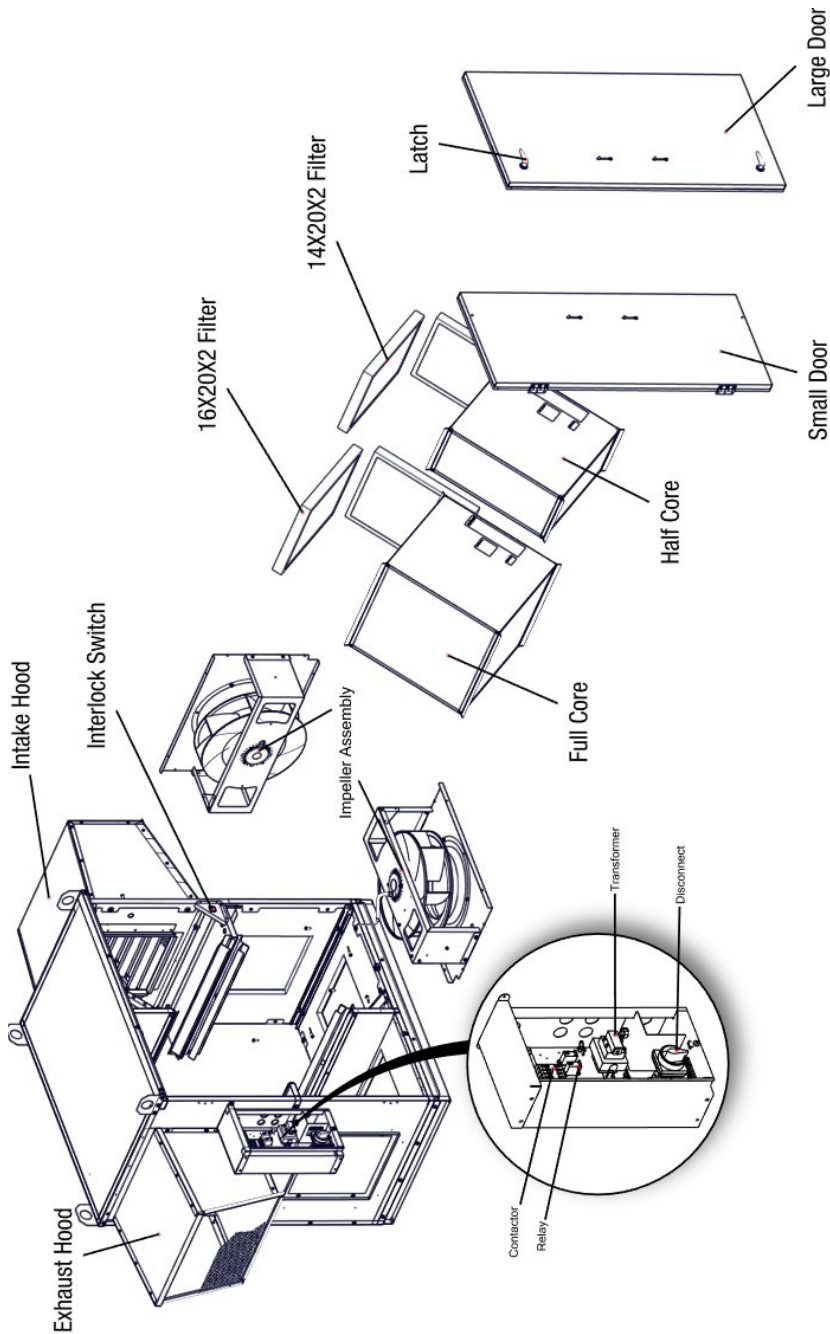

FIGURE 7.8.0 TRC1200RT SERVICE PARTS

8.0 TROUBLESHOOTING

If problems occur with a S&P USA Ventilation Systems ERV, the primary resources for troubleshooting are the unit as-built wiring schematics and the sequence of operation (SOO) for each control scheme.

S&P USA VENTILATION SYSTEMS

Enabling the World to Breathe Better Air



**ADVANCING
VENTILATION®**

S&P USA VENTILATION SYSTEMS, LLC

6393 Powers Avenue
Jacksonville, FL 32217
SolerPalau-USA.com
800.961.7370

S&P CANADA VENTILATION PRODUCTS, INC.

6710 Maritz Drive, Unit 7
Mississauga, ON L5W 0A1, Canada
SolerPalauCanada.com
416.744.1217

Soler&Palau
Ventilation Group



147678_000 (07/24)