

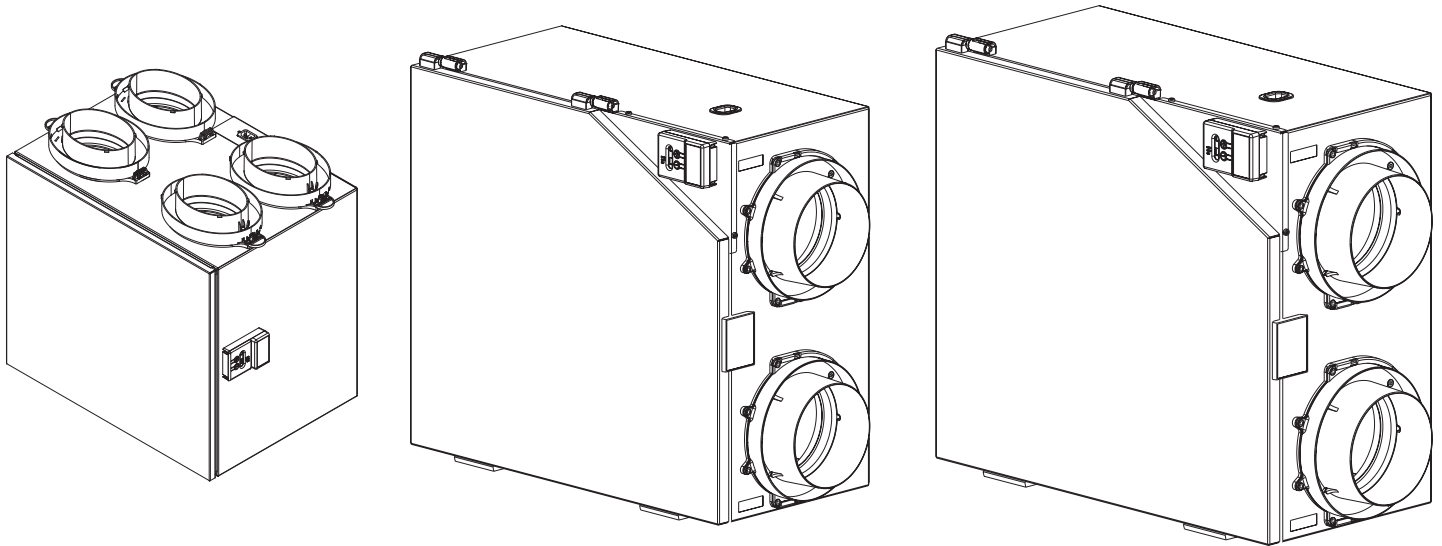

# **HR SERIES**

## **HEAT RECOVERY VENTILATOR (HRV)**

**Models HR100V, HR160H, HR220H**  
**RESIDENTIAL USE ONLY**



**INSTALLATION AND WIRING INSTRUCTIONS**  
READ AND SAVE THESE INSTRUCTIONS

## IMPORTANT - PLEASE READ MANUAL BEFORE INSTALLATION

**CAUTION:** Do not install in a cooking area or connect directly to any appliance. Turn off all integral disconnects before servicing.

**NOTICE:** Prior to installing, serious consideration must be taken to insure this ventilation system will operate properly if integrated to any other type of mechanical system, i.e. a forced air system, or an air handling unit. To insure proper operation & compatibilities of both system, it is required that the airflow's of the Heat Recovery Ventilator (HRV) be balanced, by following the procedures found in this manual.

**LIMITATIONS:** The product is for residential applications only. Must be installed in accordance with all national and local regulations, building and safety codes.



### TO REDUCE OR AVOID THE HAZARDS OF ELECTRIC SHOCK AND FIRE: CAUTIONS CONCERNING THE OPERATION AND FULL EFFICIENCY OF THIS PRODUCT:

- Before servicing or cleaning the HRV system, always remove the power cord from the AC wall outlet.
- To reduce the hazards of electric shock or fire, do not perform any service to the HRV system other than those stated in the operating manual instructions.
- To reduce the risk of electric shock, this ventilation system (HRV) comes equipped with a 3-prong plug-in. This plug will fit in a polarized outlet only one way.
- Do not use ventilation system for outdoor application.
- Do not pull or twist power cord when disconnecting it from the ventilation system. Grasp the plug firmly, not the cord.
- Do not modify the power plug in any way; if modified, risk of electric shock fire or even damage to the unit may occur.
- Do not use the ventilation system for removal of flammable fumes, gases or connect directly to any appliances.
- Use a dedicated AC 120V outlet only.
- Do not obstruct or cover the air intake or air outlet of the ventilation system.
- Do not modify, repair or disassemble this system. These tasks are to be performed by authorized serviced personnel only. Fire, electrical shock and/or bodily injury may occur if these warnings are not followed.
- To prevent injuries, do not operate the ventilation system, while servicing or maintaining. There are impeller wheels turning at a very high speed that must fully stop rotating prior to accessing the inside of the unit.
- Always assess the operation of the ventilation system on how it may interact with vented combustion equipment (ie. Gas Furnace, Oil Furnace, Combustion, Appliances, etc.)
- Do not use for swimming pool/spa applications.

## CONTENTS

SECTION	PAGE
1. Ventilation requirements . . . . .	3
2. Fitting equivalent lengths . . . . .	4
3. Types of Installations . . . . .	5
4. Installation Kit . . . . .	7
5. Finding a suitable installation area for HRV . . . . .	7
6. Installation of the HRV . . . . .	7
7. Insulated Flex from Unit to Outside Wall. . . . .	8
8. Condensation Drain Line . . . . .	8
9. Dedicated Electric Receptacle . . . . .	8
10. Outside Fresh Air and Exhaust Air Hoods . . . . .	9
11. The matrix™ High Performance Ventilation Hood . . . . .	9
12. Benefits of the Duotrol™ System. . . . .	10
13. Balancing the unit . . . . .	10
14. Controls Connection . . . . .	12
15. Wiring Diagrams for furnace interlock systems . . . . .	13
16. Troubleshooting . . . . .	14
17. Maintenance . . . . .	15
18. Warranty . . . . .	15

# 1. VENTILATION REQUIREMENTS

## DETERMINE YOUR VENTILATION NEEDS INSTALLATION

How much fresh air do I need? Good air quality is based in part on the capacity of the home's ventilation system.

Usually, the HRV's capacity is measured in CFM (Cubic Feet per Minutes) or L/s (Liters per Seconds) of fresh air being distributed in the living space. The Room Count Calculation or the Air Change per Hour Method shows you how to determine your ventilation needs.(see chart on right)

### A. Room Count Calculation

LIVING SPACE	NUMBER OF ROOMS	CFM (L/S)	=	CFM REQUIRED
Master Bedroom	_____	x 20 cfm (10 L/s)	=	_____
With Basement	_____	x 20 cfm (10 L/s)	=	_____
Single Bedroom	_____	x 10 cfm (5 L/s)	=	_____
Living Room	_____	x 10 cfm (5 L/s)	=	_____
Dinning Room	_____	x 10 cfm (5 L/s)	=	_____
Family Room	_____	x 10 cfm (5 L/s)	=	_____
Recreation Room	_____	x 10 cfm (5 L/s)	=	_____
Other	_____	x 10 cfm (5 L/s)	=	_____
Kitchen	_____	x 10 cfm (5 L/s)	=	_____
Bathroom	_____	x 10 cfm (5 L/s)	=	_____
Laundry Room	_____	x 10 cfm (5 L/s)	=	_____
Utility Room	_____	x 10 cfm (5 L/s)	=	_____
<b>TOTAL ventilation requirement (add last column) =</b>				
				1 CFM = 0.47189 L/s 1 L/s = 3.6 m3/hr

### B. Air Change per Hour Method

TOTAL cu ft X 0.35 per hr = total

Take total and divide by 60 to get CFM

**Example:** A 25'x 40' house with basement

1,000 Sq. ft. x 8' high x 2(1st floor + basement) = 16,000 cu. ft.

16,000 cu. ft. x 0.35 ACH = 5,600 cu. ft.

5,600 cu. ft. / 60 Minutes = 93.3 CFM

**93.3 CFM IS YOUR VENTILATION NEED**

## 2. FITTING EQUIVALENT LENGTHS

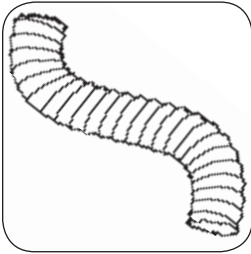

- Flex pipe equivalent length is smooth pipe x2
- Flex fitting equivalent length is smooth fitting x2

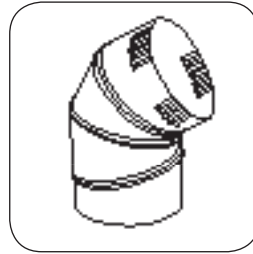

- 45° perimeter pipe elbow equivalent length = 5 ft. (1.52 m)
- NOTE:** Where flex duct is used to make 45° elbow equivalent length = 10 ft. (3.0 m)

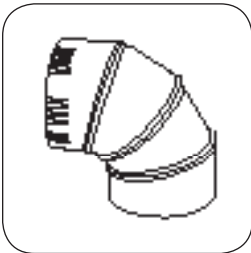

- 90° perimeter pipe elbow equivalent length = 10 ft. (3.0 m)
- NOTE:** Where flex duct is used to make 90° elbow equivalent length = 20 ft. (6.1 m)

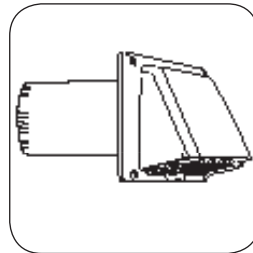

- Round wall cap spring damper or screen equivalent lengths = 60 ft. (18.29 m)

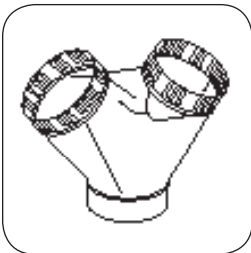

- Y-equal sides equivalent length = 10 ft. (3.0 m)

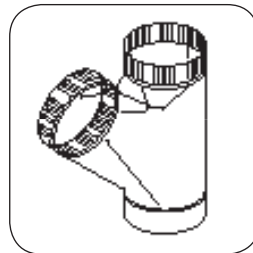

- Y-Side branch equivalent length = 35 ft. (10.7 m)

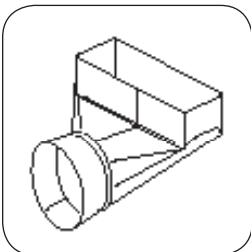

- Angle boot equivalent length = 30 ft. (9.14 m)

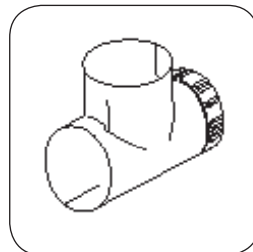

- Tee take-off equivalent length = 50 ft. (15.24 m)

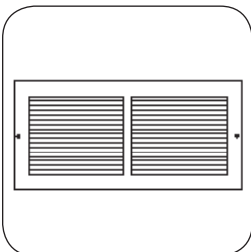

- Wall grill 50% free area equivalent length = 15 ft. (4.6 m)



- Increaser/Reducer equivalent length = 8 ft. (2.43 m)

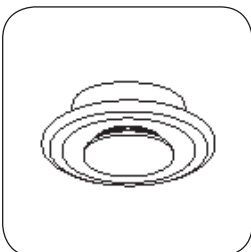

- Round plastic diffuser equivalent length = 100 ft. (30.5 m)
- NOTE:** Maximum airflow assumes diffuser is in full open position.

### 3. TYPES OF INSTALLATIONS

#### INDEPENDENT SYSTEM INSTALLATION

figure 3.1

This application uses a devoted duct system for the supply and the exhausting of stale air accumulated in the home.

It is recommended to install fresh air grilles in all bedrooms and living areas. Exhaust the stale air from the bathroom, kitchen and laundry room. (see figure 3.1)

**IMPORTANT:** For optimal performance of your HRV, the installation of an optional 6" round galvanized backdraft damper is required on the fresh air to home duct work.

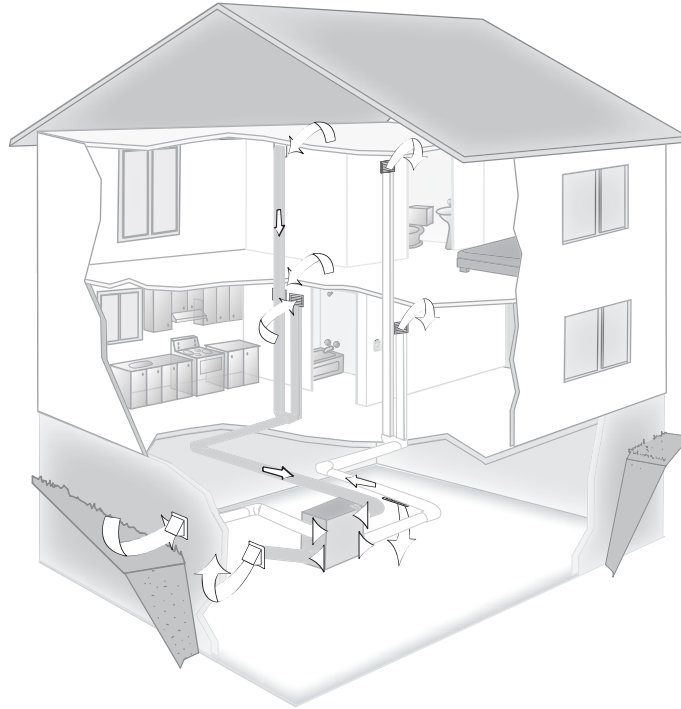

#### EXHAUST AT THE SOURCE AND SUPPLY IN THE RETURN

figure 3.2

This application uses a devoted duct system for the exhausting of stale air accumulated in the home. The fresh air is dumped into the return air duct and is distributed thru the home by the existing supply air ductwork of the forced air system. (see figure 3.2)

Make sure when using this application that your fresh air duct connection to the forced air system return air duct is not less than 10ft (3 m) upstream of the return plenum connection to the forced air system. Check with your local code or the forced air system's manufacturer. The HRV and forced air system must be in continuous mode, to achieve maximum comfort and to avoid cross-contamination.

#### NOTE TO INSTALLER:

Dwellings with multiple forced air systems requires one HRV per system.

Insure the unit runs in conjunction with forced air system (Ref. wiring diagram for furnace interlock)

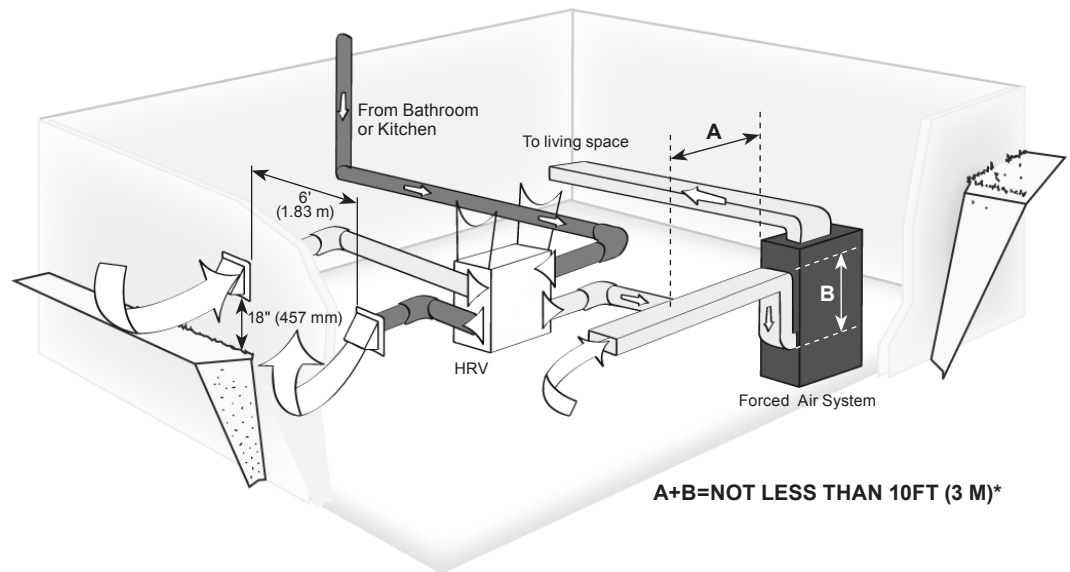

**IMPORTANT:** The duct bringing outdoor air to the return air plenum must be equipped with a manual damper to balance the outdoor airflow.

\* For minimum distance between return and forced air system, check with your local building codes and forced air system manufacturer.

**IMPORTANT:** For optimal performance of your HRV, the installation of an optional 6" round galvanized backdraft damper is required on the fresh air to home duct work. When performing duct connections, always use approved tools and material. Also use steel duct connections for these type of installs.

### 3. TYPES OF INSTALLATIONS (CONTINUED)

#### EXHAUST AND SUPPLY IN THE RETURN

When using this application make sure that there is minimum 3 feet (0.9 m) between the fresh air and exhaust air connections of the HRV in the return air duct. (see figure 3.3)

Make sure when using this application that your fresh air duct connection to the forced air system return air duct is not less than 10ft (3 m) upstream of the return plenum connection to the forced air system. Check with your local code or the forced air system's manufacturer. The HRV and forced air system must be in continuous mode, to achieve maximum comfort and to avoid cross-contamination.

#### NOTE TO INSTALLER:

Dwellings with multiple forced air systems requires one HRV per system.

Insure the unit runs in conjunction with forced air system (Ref. wiring diagram for furnace interlock)

figure 3.3

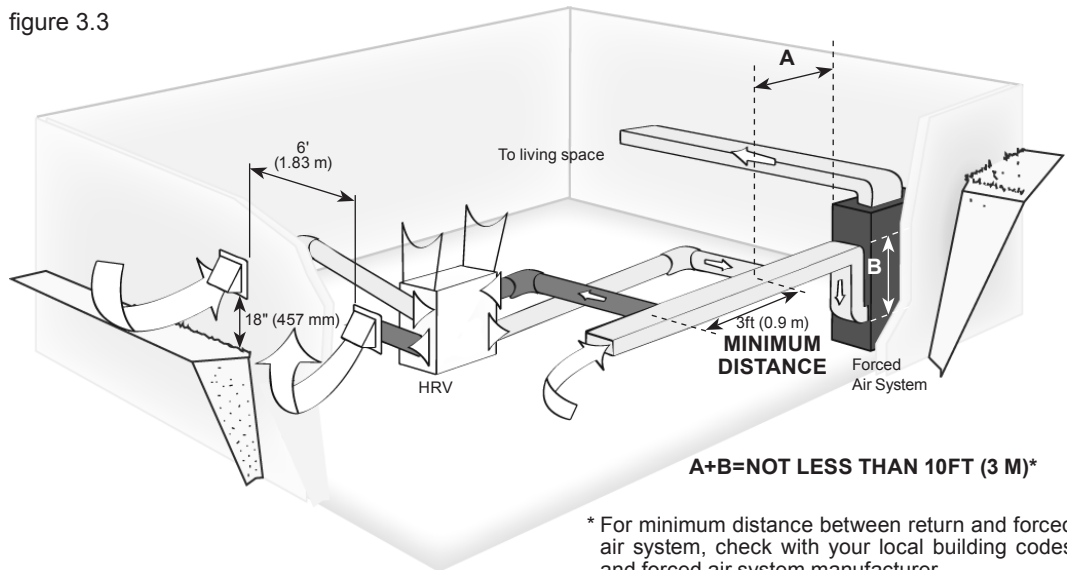

\* For minimum distance between return and forced air system, check with your local building codes and forced air system manufacturer.

**IMPORTANT:** The duct bringing outdoor air to the return air plenum must be equipped with a manual damper to balance the outdoor airflow.

**IMPORTANT:** Building and combustion appliance installation codes do not allow return air grilles or openings such as "breather tee" or indirect connections in an enclosed room that is susceptible to spillage of combustion appliances.

Simplified Connection

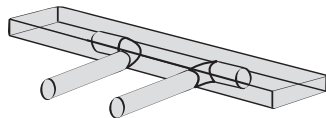

Indirect Connection

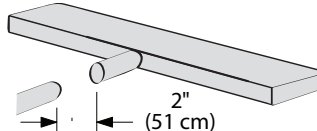

Breather Tee

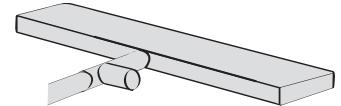

**IMPORTANT:** For optimal performance of your HRV, the installation of an optional 6" round galvanized backdraft damper is required on the fresh air to home duct work. When performing duct connections, always use approved tools and material. Also use steel duct connections for these type of installs.

### 4. INSTALLATION KIT

#### INSTALLATION KIT FOR HR100V INCLUDES:

- 4 Collars
- 4 Caps, Pressure Taps
- 1 Condensation Drain Line
- 1 Drain Adapter with Nut
- 12 screws (#10 x 1 1/4")
- 2 screws (#8 x 3/8")
- AC 120V power cord
- Wall Mounting Bracket

figure 4.1



#### INSTALLATION KIT FOR HR160H AND HR220H INCLUDES:

- 4 Collars
- 1 Condensation Drain Line
- 1 Drain Adapter with Nut
- 16 screws (#10 x 5/8")
- 4 screws (#10 x 1")
- 4 Washers
- AC 120V power cord

figure 4.2



#### TIP TO INSTALLER:

Removing the core unit will facilitate your job.

### 5. FINDING A SUITABLE INSTALLATION AREA FOR HRV

The HRV unit should be installed in a mechanical room or as close to an outside wall as possible. This would assure a short run of insulated flexible duct.

The HRV unit must always be installed in an area where the air is tempered to avoid freezing of the condensate line. The contractor should install the unit in an area that is very accessible to allow the homeowner easy access for maintenance.

It is very important to install an electric receptacle (115v) near the HRV, a separate circuit breaker is also recommended. You should have access to a condensate drain near the HRV to avoid the use of condensate pump.



## 6. INSTALLATION OF THE HRV

### Installation of the HR100V

#### **IMPORTANT** Minimum installation requirements

- A)** Minimum two 2"x 4" (50.8 mm x 101.6 mm) wood wall studs and minimum 3/8" (9.5 mm) thick drywall is required to secure the HRV wall bracket.
- B)** Support for weight of 80 lbs, which includes HRV, duct connections and accessories.

Proper installation requires that the unit be secure to the wall. If there is no wall studs available, please secure a 3/4" plywood to wall studs then fasten wall mounting bracket to plywood.

**TIP TO INSTALLER:** If the unit is not level, improper drainage will occur and could lead to moisture and leakage problems.

It is recommended to use approximately 16 inches of flexible duct between the HRV and your rigid duct. The flex duct is mounted the same way to the HRV as the insulated flex.



figure 6.1 Installation of the wall bracket. Secure with two #10 x 1 1/4" screws.



figure 6.2 Hang HRV to wall mounting bracket.



figure 6.3 When completing the procedure make sure that the HRV is leveled.



figure 6.4 Proceed to secure HRV to bracket with the two #8 x 3/8" screws.

### Installation of the HR160H and HR220H

**TIP TO INSTALLER:** Place HRV on a stepladder to ease the hanging process. If the unit is not level, improper drainage will occur and could lead to moisture and leakage problems.

It is recommended to use approximately 16 inches of flexible duct (supplied in kit) between the HRV and your rigid duct. The flex duct is mounted the same way to the HRV as the insulated flex.



figure 6.5 Attach your four straps to the floor joist making sure that you attach thru the washers and the grommets.



figure 6.6 Pull on the middle strap and gently push upward on the unit. Then repeat procedure on other side.



figure 6.7 When completing the procedure make sure that the HRV is leveled.

## 7. INSULATED FLEX FROM UNIT TO OUTSIDE WALL

**TIP TO INSTALLER:** To ensure a better installation and to avoid an undesired bend in the duct, align the duct with the collar before securing over the four hooks.

The Fresh air from outside and the Exhaust air to outside from the termination ducts to the HRV must be fully insulated of thermal insulation ducts to minimize heat loss and gain.

All tapes, mastics, and nonmetallic clamps used for field installation of flexible ducts shall be listed and labeled to Standard UL 181B - Closure Systems for Use With Flexible Air Ducts and Air Connectors.

**Air Connector** A category of flexible duct not meeting the requirements of an Air Duct per UL 181 Standard (not tested for flame penetration, puncture and impact) and having limitations on use, length and location as defined by NFPA 90A and 90B.

*Air Connectors are identified by a "round shape" listing label of the listing agency.*

**Air Duct** A category of flexible duct tested and classified as to the Surface Burning Characteristics in accordance with the UL 181 Standard

*Air Ducts are identified by a "rectangular shape" listing label of the listing agency.*



figure 7.1 Insert vinyl duct over the hooks and seal with a Tie wrap.

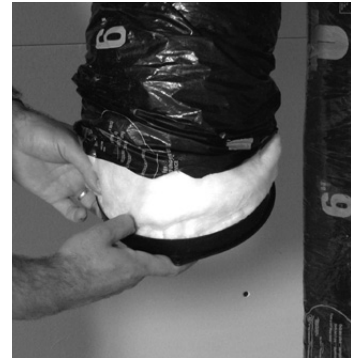

figure 7.2 Insert insulation inside the collar.

Once insulated flex is attached to the collar, slide collar in keeper section, fixed collar to the unit with four screws supplied in installation kit.



figure 7.3 Finish by taping the duct on the collar.



figure 7.4 Slide collar on the unit.

**IMPORTANT:** Always consult your national and local regulations, building and safety codes.



**WARNING:** Always fix and secure the 5" or 6 collars with the screws supplied. Avoiding this critical step the unit will accumulate condensation.

## 8. CONDENSATION DRAIN LINE

Insert the threaded drain adapter thru the bottom of the HRV and hand tighten the plastic nut, and with a wrench tighten the nut another half turn to assure a better seal.

Install the condensate line (included in drain kit). Insert condensate tubing by pushing clear plastic line over drain adapter. Make condensate trap by looping the clear plastic tubing. This procedure is to avoid foul odor to enter the HRV.

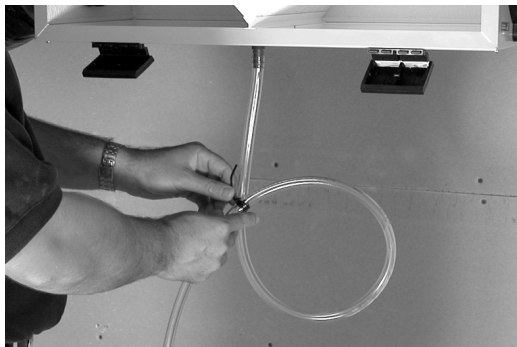

figure 8.1 Make a loop in condensate line, not be subject to freezing temperatures.



figure 8.2 Use a condensate pump if you don't have access to a drain.

## 9. DEDICATED ELECTRIC RECEPTACLE

**IMPORTANT:** Always consult a certified technician to insure proper installation of main power.

**NOTE:** If LED light on the Duotrol remains green, motors not energized controls do not operate. Polarization in main AC outlet are inverted.

It is recommended that the HRV have a dedicated receptacle with 115v. It is not recommended to connect unit with an extension cord.

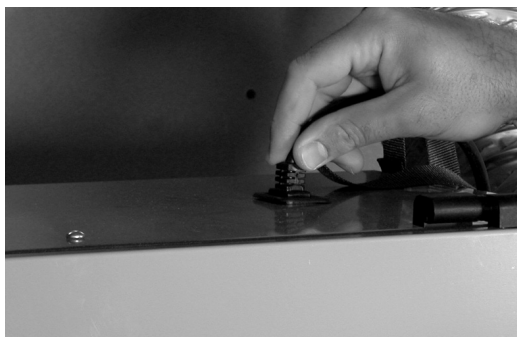

figure 9.1 Insert the power cord on top of the unit. Press firmly to make sure the power cord is secure.



figure 9.2 It is recommended that the HRV have a dedicated receptacle with 115v. It is not recommended to connect unit with an extension cord. If no receptacle is available please call an electrical contractor and have one installed. Insure polarized is correct



## 10. OUTSIDE FRESH AIR AND EXHAUST AIR HOODS

**TIP TO INSTALLER:** We recommend and it is **good practice** to have a minimum of 6ft (1.83 m) between the supply and exhaust vents, unless using a concentric vent design to prevent contamination of intake air.

**NOTE:** Outdoor air intake hoods shall be located to avoid contamination from sources such as:

- Exhaust air openings
- Driveways (auto exhaust)
- Combustion appliances
- Gas meters, oil fill pipes
- Garbage containers
- Attics or crawl spaces
- Under deck or other areas of questionable air quality



figure 10.1 Locating Outside Hoods

**IMPORTANT:** Always consult your national and local regulations, building and safety codes.

## 11. BENEFITS OF THE DUOTROL™ SYSTEM

### MODE SELECTOR

- Intermittent
- Continuous
- Off

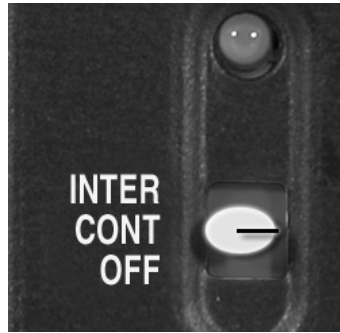

### ACTS AS A MODE SELECTOR

**INTERMITTENT:** When the selector switch is in the intermittent position the HRV will only run when there is a call for ventilation by any control. At that time the unit will run on high speed until the condition is satisfied.

**CONTINUOUS:** When the selector switch is in the continuous position the HRV will run continuously on pre set speed except when there is a call for override by any control.

**OFF:** When the selector switch is in the off position the HRV will not come on even if there's a call for ventilation by any control.

### SPEED ADJUSTMENT

- Increase Speed (+)
- Decrease Speed (-)

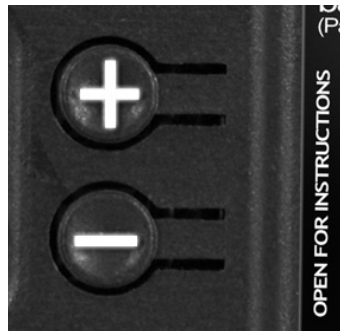

**+ BUTTON:** Increase the speed of the selected motor.

**- BUTTON:** Decrease the speed of the selected motor.

## 12. BALANCING THE UNIT

### WITH THE DUOTROL™ SYSTEM



GREEN LIGHT  
MODE SELECTOR



YELLOW LIGHT  
BALANCING MODE

### USING THE SELECTOR SWITCH

**TIP TO INSTALLER:** When on Balancing Mode, the Selector Switch allows you to choose the motor you want to set.

#### A) CLOSED DUOTROL COVER

1. **INTER** (Exhaust Motor)
2. **CONT** (Both Motors)
3. **OFF** (Supply Motor)

#### B) OPEN DUOTROL COVER

1. **UP** (Exhaust Motor)
2. **MIDDLE** (Both Motors)
3. **DOWN** (Supply Motor)

### DUOTROL™ BALANCING SYSTEM PROCEDURES, STEPS 1 THROUGH 8.

**Step 1:** Press the (+) and (-) buttons simultaneously until you see the yellow light. Once the indicator light turns yellow you are in balancing mode.

**Step 2:** When in balancing mode the selector switch becomes the motor selector switch. INTER (Right Motor), CONT (Both Motors) and OFF (Left Motor)

**Step 3:** Once the total cfm needed is determined, you can start balancing the HRV. Set your fresh air supply by selecting the «OFF» position on the Duotrol™. Install your magnehelic gauge and air flow grid in the fresh air duct.

**Step 4:** Press the (-) button to decrease the cfm or press the (+) button to increase the cfm.

**Step 5:** Then perform the same operation on the stale air side by selecting the «INTER» position on the Duotrol™.

**Step 6:** The «CONT» position will allow you to adjust the cfm on both motors proportionately (if necessary).

**Step 7:** Once this is completed, you have set the high speed on your HRV. To lock balancing mode you must press (+) and (-) buttons simultaneously and release. The indicator light will turn green to indicate normal operation mode.

**Step 8:** Once high speed is set and locked, switch to continuous on the Duotrol™. By using (+) and (-) buttons set low speed on the HRV.

## 12. BALANCING THE UNIT (CONTINUED)

### WITH THE DUOTROL SYSTEM AND THE INTEGRATED BALANCING TAPS AND MAGNEHELIC GAUGE.

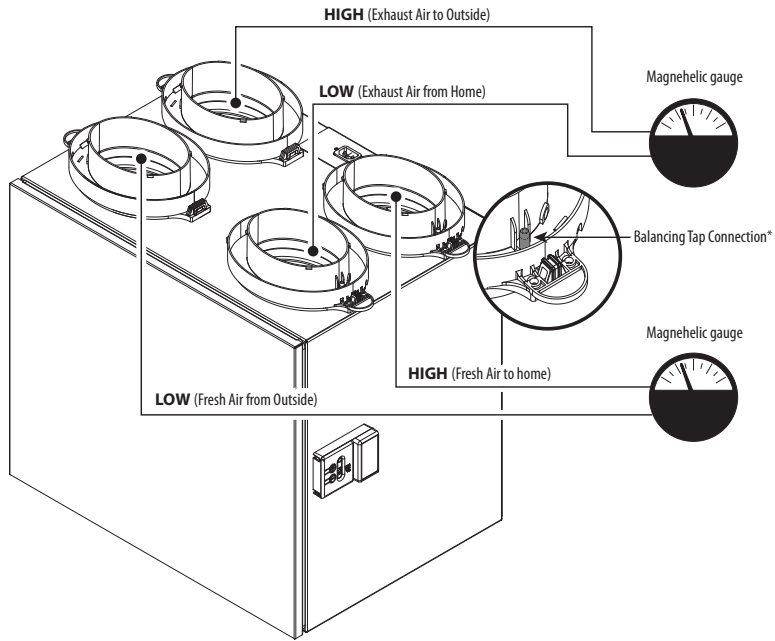

Connecting the Magnehelic gauge to the collar balancing taps, then proceed to section 13 (on page 10) Duotrol™ Balancing System Procedures and follow the Steps 1 through Step 8.

### BALANCING CHART

The balancing chart is based on a Delta P (DP) measurement (also located on the access panel of the ventilation system)

**NOTE:** To perform a proper install, the External Static Pressure (ESP) needs to be measured at each of the 4 stations. Then proceed to measure the Delta P(DP) to determine the corresponding airflow (e.g. 50 CFM), then do the iteration until the unit is balanced both the (ESP and airflows).

### Balancing Chart when using collar pressure taps.

Pressure		Fresh Air		Exhaust Air	
Pa	in. wg	L/s	CFM	L/s	CFM
50	0.20	44	93	43	90
62	0.25	41	87	40	85
75	0.30	39	83	37	79
87	0.35	37	79	36	77
100	0.40	35	74	36	76
112	0.45	33	69	34	71
125	0.50	30	65	32	67
137	0.55	29	61	28	60
150	0.60	26	56	24	51
162	0.65	24	50	22	47
175	0.70	22	46	19	41
187	0.75	19	41	17	36
199	0.80	17	36	15	31

**\*IMPORTANT:** Once balancing is complete, insure all four pressure taps are sealed with the rubber caps. Pressure taps (9753K74) supplied in the installation kit.

### WITH AN AIRFLOW GRID & MAGNEHELIC GAUGE

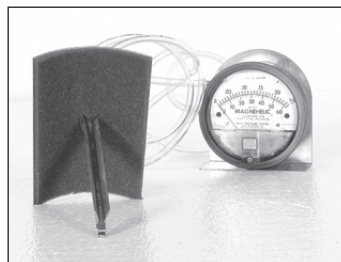

Magnehelic Gauge with Air Flow Grid



Inserting Air flow grid in duct

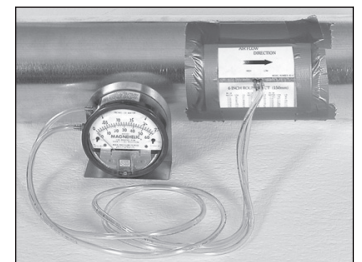

Seal Air flow grid in duct with duct tape.

# 13. CONTROLS CONNECTION

HRRD-1 (2 wires)

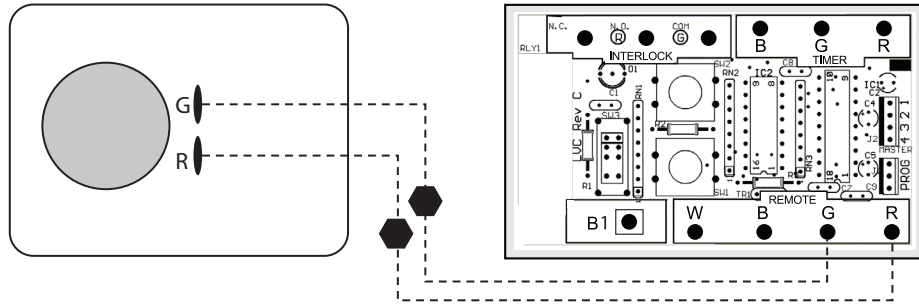

HRRD-3P(4 wires)

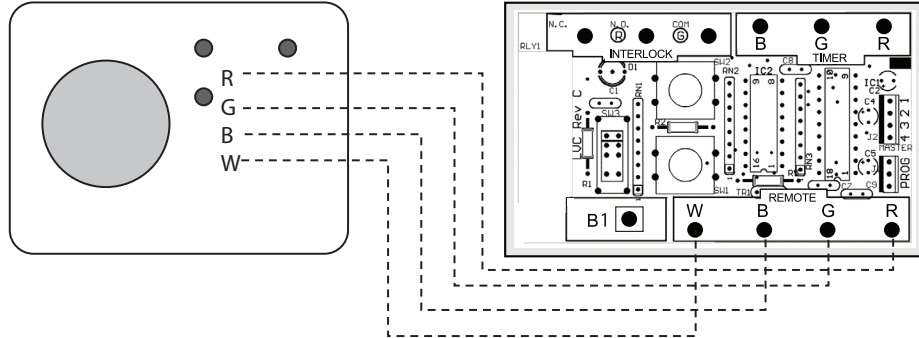

HRT-3 TIMER (3 wires)

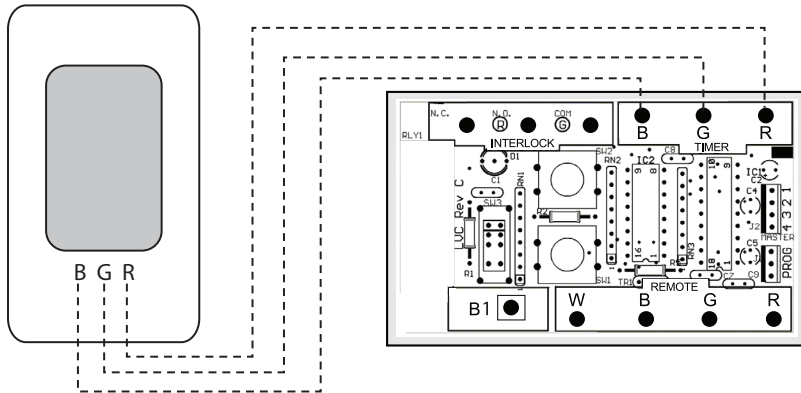

**CAUTION:** Minimum wire requirements is LVT18 CSA/UL 4 strain to insure proper connection.

# 14. WIRING DIAGRAMS FOR FURNACE INTERLOCK SYSTEMS

## STANDARD FORCED AIR INTERLOCKING WIRING

A relay is normally used when tying a ventilation system to the forced air distribution system. Our Duotrol System is equipped with an internal relay that will activate the forced air system ventilator when there is a demand from the HRV. The Duotrol System will activate the INTERLOCK relay during the following modes: Continuous, Override, Recirculation and Defrost. See wiring diagram.

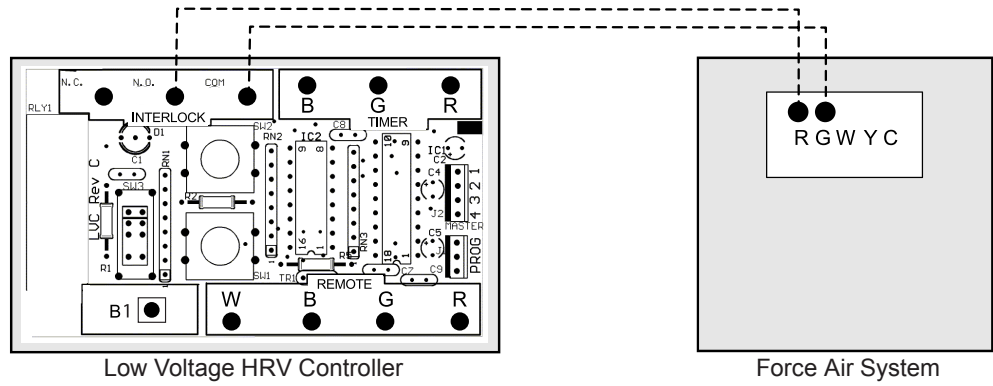

**Legend:** ----- Field Installed Low Voltage

Figure 14.1 Standard forced air wiring diagram

## ALTERNATE FORCED AIR INTERLOCKING WIRING

Some forced air system thermostat will activate the cooling system when tied using the «Standard forced air interlocking wiring».

If you have identify this type of thermostat you must proceed with the «Alternate Forced Air Wiring».

## LOCATING THE WIRING DIAGRAM

**NOTE TO INSTALLER:** Wiring Diagram for the entire line of HRV Models are placed on the back of each Exhaust motor bracket.

**CAUTION:** Thermostat that control A/C system must use the Alternate Interlock Wiring Diagram.

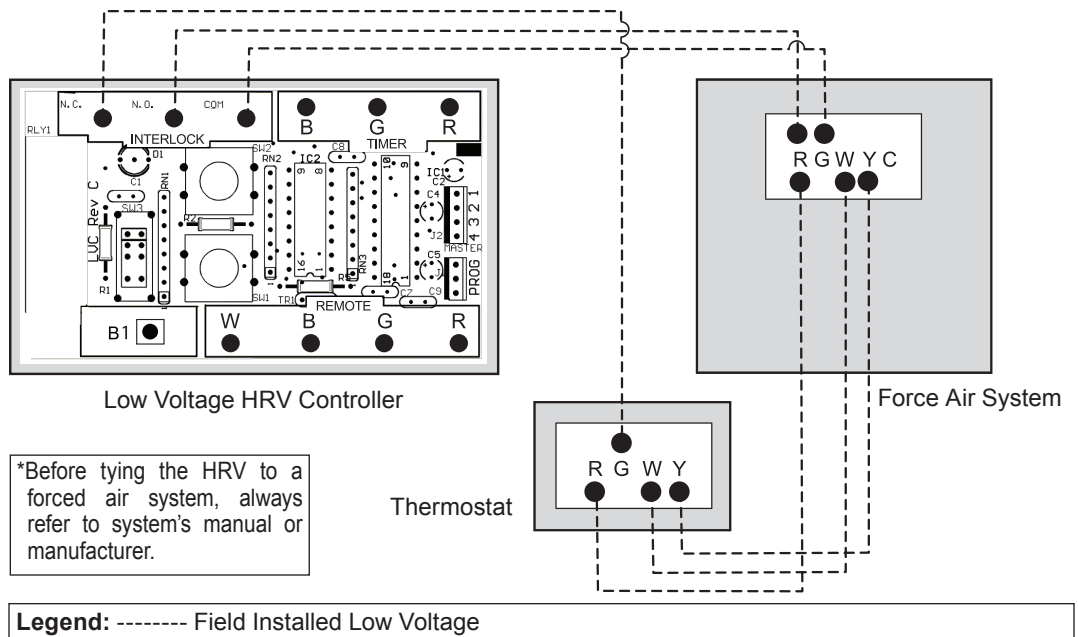

\*Before tying the HRV to a forced air system, always refer to system's manual or manufacturer.

**Legend:** ----- Field Installed Low Voltage

Figure 14.2 Alternate forced air wiring diagram



**WARNING:** Always disconnect the unit prior to making any connections. Failure to disconnecting the power could result in electrical shock or can damage the electronic boards, wall controls and/or unit.

**CAUTION:** Minimum wire requirements is LVT18 CSA/UL 4 strain to insure proper connection.



## 15. TROUBLESHOOTING

QUESTION / ITEM	DIAGNOSIS / SOLUTION
<ul style="list-style-type: none"> <li>• HRV not running</li> </ul>	<ul style="list-style-type: none"> <li>• Verify breaker in main electrical panel</li> <li>• Verify the HRV is in the ON position</li> <li>• Verify the all wall controls switch on the HRV are activated to supply power to the unit</li> <li>• Unplug HRV verify if the controller is wired correctly to the connection box on the side of the unit</li> <li>• Verify main outlet polarization</li> </ul>
<ul style="list-style-type: none"> <li>• Air is too dry</li> </ul>	<ul style="list-style-type: none"> <li>• Reduce the humidity level on the controller</li> <li>• Reduce continuous airflow rate</li> <li>• Switch ventilation mode from continuous to intermittent</li> <li>• Humidifier recommended if heating source is a forced air system</li> </ul>
<ul style="list-style-type: none"> <li>• Air too humid</li> </ul>	<ul style="list-style-type: none"> <li>• Suggest continuous operation of HRV</li> <li>• Increase humidity level on dehumidistat</li> <li>• Increase continuous airflow rate</li> <li>• Insufficient ventilation, check capacity</li> <li>• Internal source of moisture, e.g. heating wood store in basement, possible leaks or poor insulation R-value and or dryer is venting in basement</li> </ul>
<ul style="list-style-type: none"> <li>• Vibration or noise</li> </ul>	<ul style="list-style-type: none"> <li>• Verify that vibration mounting straps, hanging chains or wall bracket is used for hanging the units.</li> <li>• Verify that flexible duct connections are use between the HRV and the rigid duct.</li> <li>• Verify that the motors are operating and are not obscured by any debris</li> <li>• Insure motor moves freely with turning by hand.</li> </ul>
<ul style="list-style-type: none"> <li>• Cold air</li> </ul>	<ul style="list-style-type: none"> <li>• Misplaced supply outlets</li> <li>• Defrost no operating correctly</li> <li>• The HRV not properly balanced</li> <li>• High airflow on furnace continuous mode</li> <li>• Insure HRV is interlock when integrated with forced air system</li> </ul>
<ul style="list-style-type: none"> <li>• Contamination or Pollutants</li> </ul>	<ul style="list-style-type: none"> <li>• Insure proper clearance of ventilation hoods from source of contaminants Refer to section 10. Outside Fresh Air and Exhaust Air Hoods.</li> </ul>
<ul style="list-style-type: none"> <li>• Condensation</li> </ul>	<ul style="list-style-type: none"> <li>• Verify that the HRV is level to insure proper drainage</li> <li>• Verify that the duct connection are fix and secured with screws to the HRV.</li> <li>• Verify the cold side duct connections are fully insulated and that vapor barrier is taped to insure a proper seal.</li> <li>• Look for signs of crushed section, failing duct straps, puncture vapor barrier, missing insulation.</li> <li>• Insure proper seal of vapor barrier to outside wall.</li> <li>• Look for sign of water accumulation/leakage/dripping</li> <li>• Verify that the drain connection is not kinked; the "P" trap is not to close to unit or obscured with debris.</li> </ul>

## 16. MAINTENANCE

### ROUTINE MAINTENANCE

#### SEVEN-STEP MAINTENANCE SCHEDULE

With routine preventative maintenance, you can avoid unnecessary problems, ensure the effectiveness of your HRV, and prolong its life. For additional specific instructions, refer to your HRV operating manual or ask the contractor who installed or services the HRV to demonstrate the proper maintenance procedures.



#### **WARNING:**

BE SURE TO DISCONNECT THE ELECTRICAL POWER BEFORE SERVICING YOUR SYSTEM

1. Clean or replace air filters. Filters, which are located within the HRV should be cleaned every two to three months. Filters should be vacuumed first, then washed with a mild soap and water. Most washable filters will last several years before needing to be replaced.
2. Clean the exterior intake and exhaust vents of obstructions. Check the outside vents regularly to ensure that the screen openings are not obstructed by grass, bushes, leaves, snow or other debris.
3. Clean and inspect the heat-exchange core and aluminum louvers (*Ref. Fig. 17.1 for proper orientation of louvers*). Twice a year and clean it as required (consult your owner's manual for instructions on inspecting and cleaning the core). A build-up of dust and dirt can restrict airflow and reduce the efficiency of your HRV. After inspection and cleaning, make sure the core is replaced right-side-up.
4. Clean the condensate drain and pan. Twice a year, check the condensate drain and tubing to ensure that they are open and free-flowing. The tubing can be disconnected for cleaning. The condensate drain must have a "trap" in the tubing that traps a quantity of water – to prevent air from entering the HRV via this tubing
5. Service the fans. The fans on the HRV's are designed to operate continuously without lubrication. Inspect the blower fans periodically for dirt on the blades, and remove it by gently brushing the blades or using a vacuum cleaner.
6. Clean the grilles and inspect the ductwork. Clean the grilles when they are dusty. At least once a year, visually inspect the ductwork leading to and from the HRV. Damaged ducts can lead to condensation problems, including wet insulation, water on the floor and, ice build-up. If the insulation itself is damaged.
7. Arrange for an annual servicing. Your HRV should undergo annual general servicing by a certified contractor and who is familiar with your HRV. If possible, have your furnace and HRV serviced at the same time; this will result in less inconvenience and cost than two separate visits.

## 17. WARRANTY

S&P warrants the polypropylene heat recovery core against defects in material and workmanship for a lifetime from the date of original installation; and all other components to be free from defects in material and workmanship for five (5) years. Any units or parts which prove to be defective and are reported during the warranty period will be replaced at our option when returned to our factory, transportation prepaid. Deterioration or wear by heat, abrasive action, chemicals, improper installation or operation or lack of normal maintenance shall not constitute defects, and are not covered by warranty.

S&P will not be responsible for any installation, removal or re-installation costs or any consequential damage resulting in failure to meet conditions of any warranty.

#### **LIMITATION OF WARRANTY AND LIABILITY**

This warranty does not apply to any such S&P product or parts which have failed as a result of faulty installation or abuse, or incorrect electrical connections or alterations, made by others, or use under abnormal operating conditions or misapplication of the products and parts.

S&P will not approve for payment any repairs made outside the factory without prior written consent.

The foregoing shall constitute our sole and exclusive warranty and our sole and exclusive liability and is in lieu of all other warranties, whether written, oral, implied or statutory. There are no warranties which extend beyond the description of the page hereof. Seller does not warrant that said goods and articles are of merchantable quality or that they are fit for any particular purpose. The liability of seller on any claim of any kind, including negligence, for any loss or damage arising out of or connected with, or resulting from the sale and purchase of the products and parts covered by this proposal, acknowledgement, order or from the performance or breach of any contract pertaining to such sale or purchase, or from the design, manufacture, sale, delivery, resale, installation, technical direction of installation, inspection, repair, operation or use of any products or parts covered by this proposal, acknowledgement, order or furnished by seller shall, in no case exceed the price allocable to the products or parts thereof which give rise to the claim and shall terminate one (1) year after the shipment of said products and parts.

In no event, whether as a result of breach of contract, or warranty or alleged negligence, defects, incorrect advice or other causes, shall seller be liable for special or consequential damages, including, but not limited to, loss of profits or revenue, loss of use of the equipment or any associated equipment, cost of capital, cost of substitute equipment, facilities or services, down time costs, or claims of customers of the purchaser for such damages. S&P neither assumes nor authorizes any persons to assume for it any other liability in connection with the sale of its fan products and parts. Some states do not allow the exclusion or limitation of incidental or consequential damages, so all of the above limitations or exclusions may not apply to you.

#### **SAFETY ACCESSORIES WARNING:**

The responsibility for providing safety accessories for equipment supplied by S&P is that of the installer and user of this equipment. S&P sells its equipment with and without safety accessories, and accordingly it can supply such safety accessories upon receipt of order.



**S&P USA Ventilation Systems, LLC    S&P Canada Ventilation Products, Inc.**

6393 Powers Avenue Jacksonville, FL 32217 P. 904-731-4711 · F. 904-737-8322 <a href="http://www.spvg-northamerica.com">www.spvg-northamerica.com</a>	5600 Ambler Drive Mississauga, ON L4W 2K9 - Canada Tel. 416-744-1217 · Fax 416-744-0887 <a href="http://www.solerpalaucanada.com">www.solerpalaucanada.com</a>
---------------------------------------------------------------------------------------------------------------------------------------------------------------	-------------------------------------------------------------------------------------------------------------------------------------------------------------------------

