

MODEL FEATURES

- Polypropylene HRV core
- 3 operating modes
- Painted galvanized steel case
- Designed for simple installation by a single person
- Fully insulated case
- **Limited lifetime warranty** on the heat recovery core
- 5-year warranty on balance of unit

MODEL OVERVIEW

The JencoFan HR Series heat recovery ventilators (HRVs) are ideal for use in cold climates where home heating is essential. The HR Series uses one motor to exhaust stale room air and another motor to bring fresh outdoor air back into the house. The technology of a plate heat recovery core is that it transfers warm ambient air from one airstream to the other without mixing the air streams for maximum efficiency and comfort.

The HR Series has been engineered & designed to improve indoor air quality by reducing excess humidity or other contaminants during the winter time, and replacing this air by fresh filtered air from the outdoors. During colder seasons, the units heat recovery core (polypropylene core) will reclaim the heat from the outgoing stale air and use this heat to temper the incoming fresh air, which reduces the cost of effectively ventilating the home during winter. This process is reversed in the summer months.



Model HR is available
in our Quickship program.
All sizes are available for next
day shipping from stock.

Limited Lifetime core warranty. 5-year warranty on balance of unit.

All specifications are subject to change without notice unless approved in submittal by JencoFan.

GC_HR_0114

January 2012

STANDARD SPECIFICATIONS AND FEATURES

- Polypropylene HRV core
- 3 operating modes (Intermittent, Continuous and High Speed)
- Duotrol™ balancing system reduces noise that would be produced by balancing dampers
- Unique collar system for easy manipulation of duct for better and quicker installation
- Painted galvanized steel case
- Designed for simple installation by a single person
- Washable filters
- Fully insulated case
- **Limited lifetime warranty** on the heat recovery core
- 5-year warranty on balance of unit

The HRV Core

- During colder seasons the core will reclaim the heat from the outgoing stale air and reuse this heat to temper the incoming fresh air
- Designed to maximize airflow and performance
- Reduces the cost of effectively heating the home during the winter
- Constructed from a composite of polypropylene materials that allows latent heat transfer from one airstream to another while preventing cross contamination
- Polypropylene (plastic) core reduces condensation compared to aluminum cores
- Limited lifetime warranty

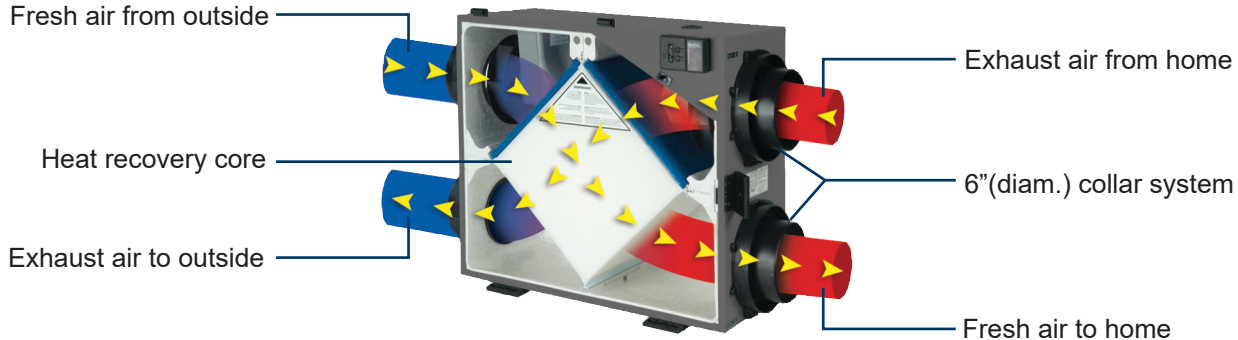

Types of Installation

The HR Series can be installed as independent systems that use independent ductwork or they can be connected to the existing duct of the forced air heating or cooling system. The “Best” and “Better” systems meet the ASHRAE 62.2 Whole Building requirement when using an JencoFan HR control (see pg 18).

The Best System: Independent System

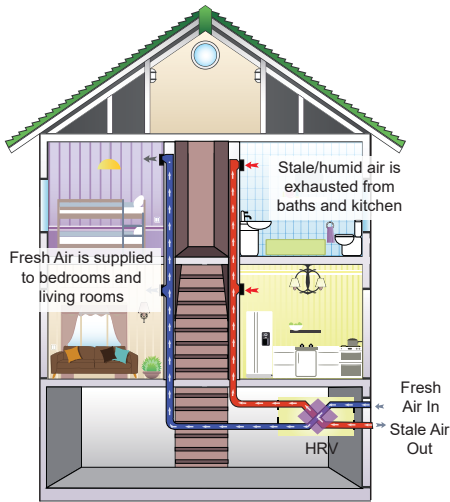

The Better System: Exhaust at the source and supply in the return

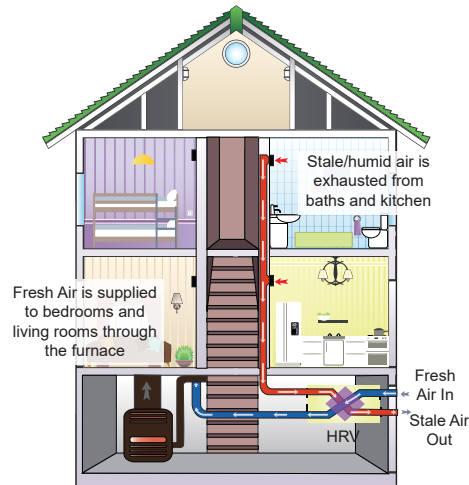

The Good System: Exhaust and supply in the return

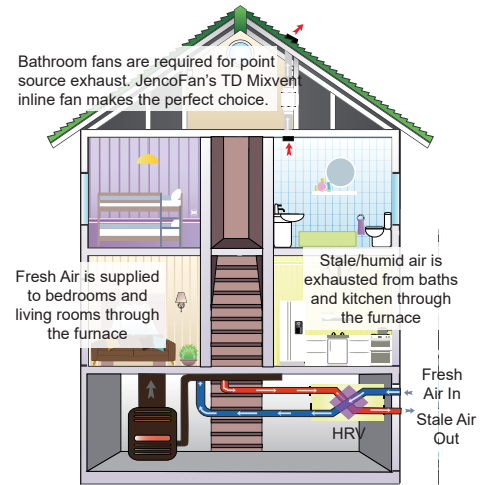

JencoFan's HRV System

- **Duotrol™ Systems:** Selects ventilation modes (OFF, CONT or INTER), also to adjust the continuous airflow rates: Increasing (+)/Decreasing (-).
- **Motors(2):** Designed with high performance and reliability, they are maintenance free for comfort and peace of mind.
- **Synthetic Filters:** Capture the largest particle & protects the heat recovery core from potential obstruction by these particles.
- **Heat Recovery Core:** A polypropylene cross-flow type it is designed to transfer the heat between both exhaust & supply air streams without allowing any contamination or mixing of both air streams to maximize the efficient and improve indoor air quality.
- **Condensate Drain Pan & Drainage Hose:** Captures the water that accumulates during the heat transfer and defrosts sequence in the fall, winter & early spring seasons. Drain hose is connected to the drain pan and serves as drainage for the accumulation of water. It is normal during summer months to find no condensation in drain pan or in drainage hose.
- **Automatic Defrost Sequence:** The defrost sequence is electronically controlled to measure the incoming outdoor air temperature, the sequence is activated at -5°C (23°F) and colder and the duration is for 5 minutes then returns to normal operation for 25 minutes. This system eliminates that the heat recovery core doesn't build with ice or freezes.
- **Defrost sequence:** Supply fan shuts down, the exhaust fan speed increases pending the measured outside temperature.



CONTROLS



HRT-3 - Push Button Timer

- The HRT-3 model push button timer allows the homeowner control of the indoor humidity level in rooms where excess humidity is produced
- Press the button once the LED comes on then release, this activates the ventilation system to high speed for 20 minutes.
- Press the button until the LED blinks 2 times then release, this activates the ventilation system to high speed for 40 minutes.
- Press the button until the LED blinks 3 times then release, this activates the ventilation system to high speed for 60 minutes.
- Meets ASHRAE 62.2 continuous ventilation standards



HRRD-1 - Dehumidistat

- The HRRD-1 allows the users to select the humidity level using the Relative Humidity Sensor Dial
- The Relative Humidity Sensor Dial will “click” when the dial reaches approximate level of relative humidity and overrides the ventilation system to high speed once the level of humidity is above the set point
- For best results install in bathrooms, kitchen and laundry room
- Meets ASHRAE 62.2 continuous ventilation standards



HRRD-3P - Dehumidistat

- The HRRD-3P allows the users to select the humidity percentage, fan range and operation modes.
- Includes Relative Humidity Sensor, Speed Control Selector Switch and Mode Selector Switch
- The Relative Humidity Sensor Dial will “click” when the dial reaches approximate level of relative humidity and overrides the ventilation system to high speed once the level of humidity is above the set point
- Speed Control (OFF, NORMAL and REDUCED)
- Mode Control (INTERM and CONT)
- For best results install in bathrooms, kitchen and laundry room
- Meets ASHRAE 62.2 continuous ventilation standards

HR100V



Specifications

Polypropylene HRV Core: cross-flow that transfers sensible heat			
Typical Airflow Range: 30-100 CFM			
Duct Connections: Four (4) 5" oval ISF double collar system			
Number Motors: Two (2) PSC variable speed backward curved			
V	Hz	Phase	Amperage
120	60	Single	0.85 A / 66 watts
Exchange surface: 63.5 ft ²			
Defrost type: Evacuation			
Filters: Two (2) Fiberbond washable			
Drain Connection: 1/2"			
DuoTrol: Integrated Balancing System			
Weight: 33.5 lbs (unit), 41 lbs (in carton)			
Dimensions: 22" W x 19-13/16" L x 14-19/32" H			
Options: HRT-3 - Push Button Timer HRRD-1 - Dehumidistat HRRD-3P - Dehumidistat			

Energy Performance (Heating)

Supply Temperature		Net Air Flow		Power Consumed (Watts)	Sensible Recovery Efficiency	Apparent Sensible Effectiveness
°F	°C	CFM	L/s			
32	0	40	19	28	64	72
32	0	65	30	40	59	66
-13	-25	37	18	30	55	73

Ventilation Performance

External Static Pressure		Net Air Flow		Gross Air Flow Supply		Gross Air Flow Exhaust	
Pa	in. w.g.	L/s	CFM	L/s	CFM	L/s	CFM
25	0.1	47	99	48	100	48	102
50	0.2	44	93	45	94	43	92
75	0.3	39	83	40	84	38	80
100	0.4	35	75	35	75	36	78
125	0.5	30	65	30	66	32	68
150	0.6	27	56	27	57	25	52
175	0.7	22	46	22	47	19	41

Dimensions

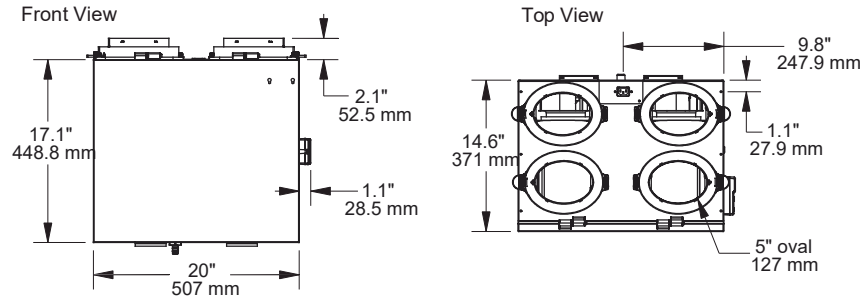

Minimum Clearance Data

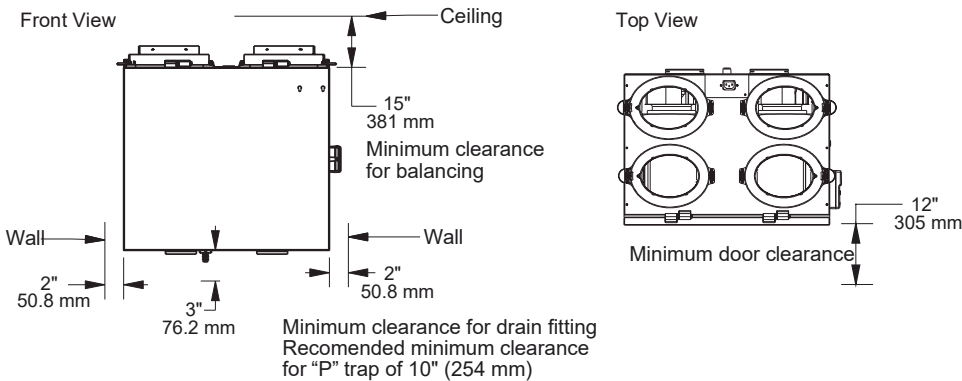

HR160H

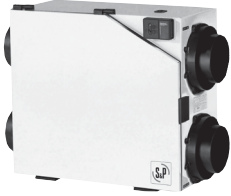

Specifications

Polypropylene HRV Core: cross-flow that transfers sensible heat			
Typical Airflow Range: 30-160 CFM			
Duct Connections: Four (4) 6" dia. ISF double collar system			
Number Motors: Two (2) PSC variable speed backward curved			
V	Hz	Phase	Amperage
120	60	Single	1.5 A / 142 watts
Exchange surface: 85 ft ²			
Defrost type: Evacuation			
Filters: Two (2) Fiberbond washable			
Drain Connection: 1/2"			
DuoTrol: Integrated Balancing System			
Weight: 43 lbs (unit), 49 lbs (in carton)			
Dimensions: 29-1/2" W x 22-1/2" L x 11-3/8" H			
Options: HRT-3 - Push Button Timer HRRD-1 - Dehumidistat HRRD-3P - Dehumidistat			

Energy Performance (Heating)

Supply Temperature		Net Air Flow		Power Consumed (Watts)	Sensible Recovery Efficiency	Apparent Sensible Effectiveness
°F	°C	CFM	L/s			
32	0	65	31	72	66	75
32	0	83	39	80	63	72
32	0	107	50	94	60	67
-13	-25	76	36	72	56	73

Ventilation Performance

External Static Pressure		Net Air Flow		Gross Air Flow Supply		Gross Air Flow Exhaust	
Pa	in. w.g.	L/s	CFM	L/s	CFM	L/s	CFM
25	0.1	91	193	91	194	103	217
50	0.2	84	178	85	179	95	201
75	0.3	77	163	77	163	86	183
100	0.4	71	150	71	151	80	169
125	0.5	63	133	63	134	71	152
150	0.6	57	120	57	121	66	138
175	0.7	51	109	51	109	57	121

Dimensions

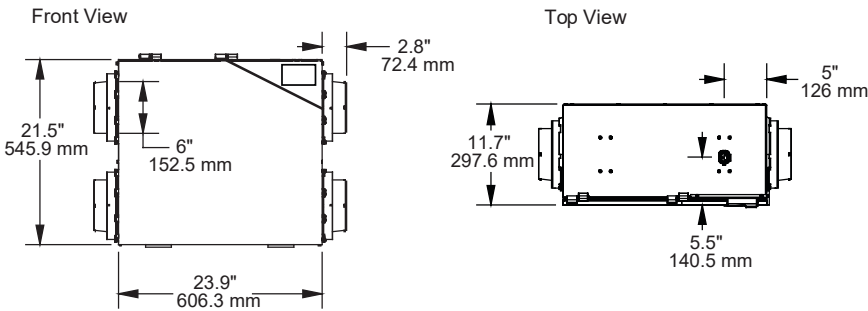

Minimum Clearance Data

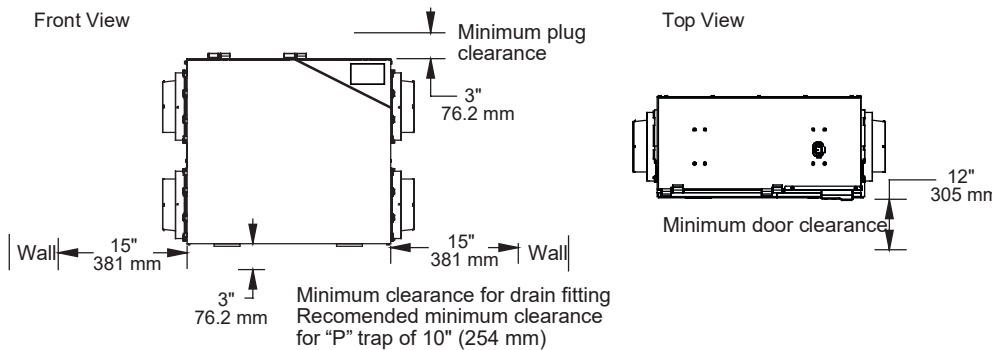

HR220H

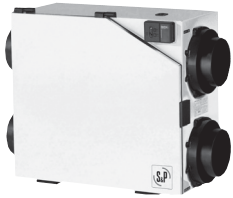

Specifications

Polypropylene HRV Core: cross-flow that transfers sensible heat			
Typical Airflow Range: 70-220 CFM			
Duct Connections: Four (4) 6" dia. ISF double collar system			
Number Motors: Two (2) PSC variable speed backward curved			
V	Hz	Phase	Amperage
120	60	Single	1.5 A / 142 watts
Exchange surface: 150 ft ²			
Defrost type: Evacuation			
Filters: Two (2) Fiberbond washable			
Drain Connection: 1/2"			
DuoTrol: Integrated Balancing System			
Weight: 51 lbs (unit), 59 lbs (in carton)			
Dimensions: 29-1/2" W x 22-1/2" L x 16-1/2" H			
Options: HRT-3 - Push Button Timer HRRD-1 - Dehumidistat HRRD-3P - Dehumidistat			

Energy Performance (Heating)

Supply Temperature		Net Air Flow		Power Consumed (Watts)	Sensible Recovery Efficiency	Apparent Sensible Effectiveness
°F	°C	CFM	L/s			
32	0	118	55	106	61	71
32	0	160	75	132	58	65
32	0	185	87	150	55	62
-13	-25	120	57	105	58	72

Ventilation Performance

External Static Pressure		Net Air Flow		Gross Air Flow Supply		Gross Air Flow Exhaust	
Pa	in. w.g.	L/s	CFM	L/s	CFM	L/s	CFM
25	0.1	117	248	118	250	130	277
50	0.2	108	229	109	231	119	253
75	0.3	102	218	103	220	110	234
100	0.4	94	200	95	202	101	216
125	0.5	85	181	86	183	92	197
150	0.6	77	163	78	165	82	175
175	0.7	69	146	70	148	71	151

Dimensions

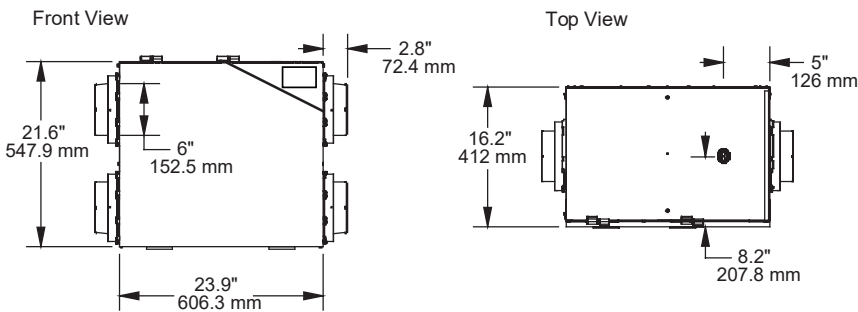

Minimum Clearance Data

