

STANDARD FEATURES

(For STXB, STXB-HP, STXB-W, and STXB-RHUL and their variants)

- Attractive spun aluminum exterior
- Belt drives permit easy performance adjustments when needed
- Curved non-overloading backward inclined wheel for efficiency at higher static pressures
- Conduit provided through base of unit for electrical connection
- AMCA Air and Sound Licensed
- NFPA - suitable for National Fire Protection Association Installations
- cULus 705

STXB-W FEATURES

- Sizes 8-24 are wall mount capable
- Roof or sidewall mounting options
- cULus 705 or 762

STXB-RHUL FEATURES

- For restaurant exhaust
- Galvanized steel base
- Electrical connection located on shroud side with weather proof junction box
- cULus 762

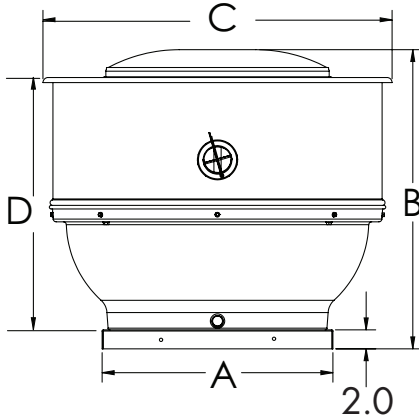

Size	DIMENSIONS							
	A	B	C	D	Roof Opening	Curb (O.D.)	Damper (O.D.)	Average Ship Wt. Lbs.
8	18	29 5/16	28 5/8	24 5/16	13 1/2	16 1/2	12	109
10	18	29 5/16	28 5/8	24 5/16	13 1/2	16 1/2	12	109
12	20	30 7/8	31 5/16	25 15/16	15 1/2	18 1/2	14	122
14	20	30 7/8	31 5/16	25 15/16	15 1/2	18 1/2	14	126
15	24	31 1/2	36 1/2	26 5/8	19 1/2	22 1/2	18	140
16	24	31 1/2	36 1/2	26 5/8	19 1/2	22 1/2	18	140
18	30	35 3/4	42 5/8	30 1/2	25 1/2	28 1/2	24	171
20	30	38 5/8	46 7/16	30 1/2	25 1/2	28 1/2	24	178
22	30	38 5/8	46 7/16	33 5/16	25 1/2	28 1/2	24	178
24	36	49 1/8	50 1/2	37 1/2	31 1/2	34 1/2	30	290
27	36	51 5/8	61 5/16	41 1/2	31 1/2	34 1/2	30	300
30	42	52 5/16	65 7/16	42 1/4	37 1/2	40 1/2	36	336

NOTE: All dimensions shown are in inches.

FAN SPECIFICATIONS									MOTOR SPECIFICATIONS				
Line	Qty.	Model No.	Tag	CFM	SP	Fan RPM	BHP	Sones	HP	Volts	Phase	Hertz	Encl
1													
2													
3													

ACCESSORY ITEMS					1	2	3	4	5	ACCESSORY ITEMS					1	2	3	4	5
<input type="checkbox"/>										<input type="checkbox"/>									
<input type="checkbox"/>										<input type="checkbox"/>									
<input type="checkbox"/>										<input type="checkbox"/>									