

JencoFan Synthetic Filters are 2" deep and features a uniform 100% synthetic, self-supporting media design that achieves a MERV 8 per the ANSI/ASHRAE 52.2 Test Standard. A metal support grid is not necessary due to the double wall internal torsion box technology. The media is resistant to a wide range of chemicals, does not absorb moisture and will not support microbial growth.

The controlled pleat spacing maximizes surface area and dust holding capacity and is bonded to the enclosure frame to prevent dust bypass. The enclosure frame is constructed of high wet strength moisture resistant beverage board.

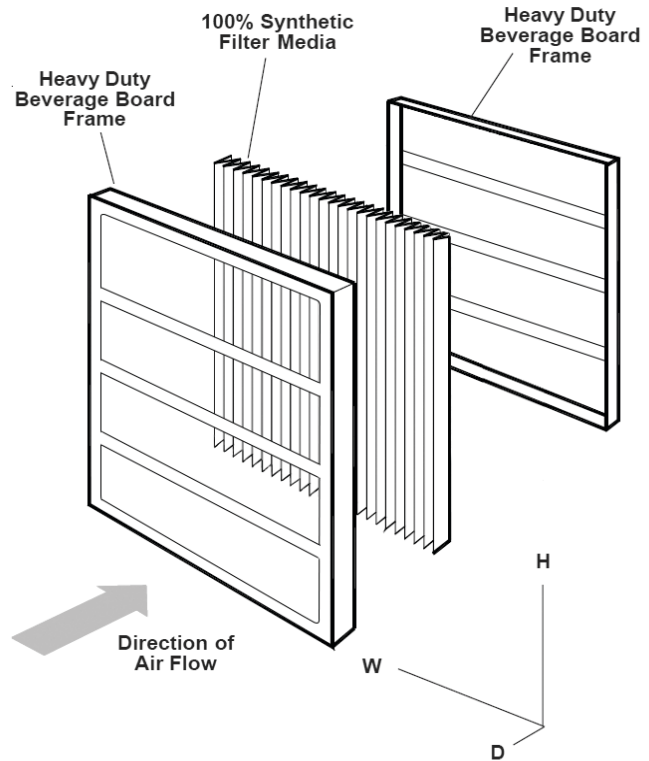

FILTER PART NUMBER	DESCRIPTION	SIZE	W	H	D
990080	Single filter for TRC500	14x20x2	13-1/2	19-1/2	1-3/4
990091	Case of 12 filters for TRC500	14x20x2	13-1/2	19-1/2	1-3/4
990083	Single filter for TRC800 & 1600	20x20x2	19-1/2	19-1/2	1-3/4
990084	Case of 12 filters for TRC800 & 1600	20x20x2	19-1/2	19-1/2	1-3/4

<b>Filter Media</b>	100% Synthetic Fiber
<b>Filter Support Grid</b>	Moisture resistant double wall beverage board
<b>Frame</b>	Moisture resistant double wall beverage board
<b>Assembly Technique</b>	Media pack totally bonded to frame
<b>Max. Temperature</b>	150°F (66°C) continuous service
<b>Max. Humidity</b>	Resistant to 100% R.H.
<b>Flammability</b>	U.L. 900 Classified