

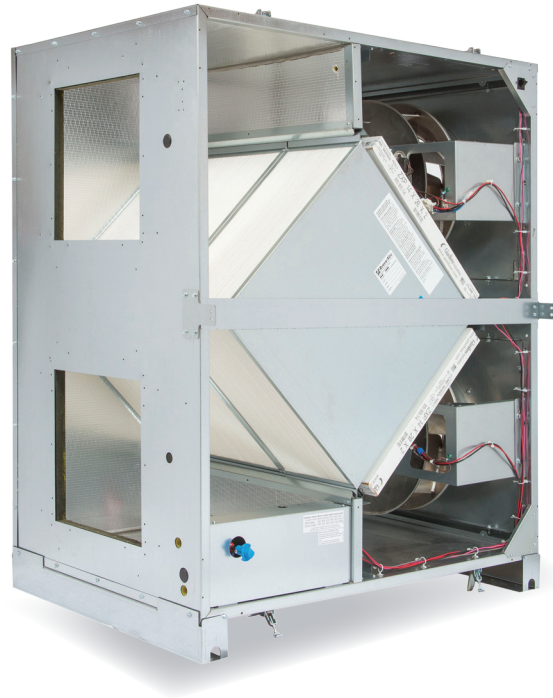

# TRC1200

## ENERGY RECOVERY VENTILATOR

Installation, Operation & Maintenance Manual



**TABLE OF CONTENTS**

TRC 1200 info ..... 3-4  
 Installation ..... 5-14  
 Start-up & Operation ..... 15-17  
 Maintenance ..... 18-19

**ABOUT S&P USA VENTILATION SYSTEMS**

S&P USA Ventilation Systems (S&P USA) operations are based in Jacksonville, Florida. This geographically strategic location allows the shipment of products throughout the US and Canada. The Jacksonville manufacturing facility has more than 150,000 square feet of warehouse space for the stocking of a comprehensive range of products. This permits the overnight delivery of many popular model sizes to anywhere in the US and Canada.

At S&P USA we take pride in the fact that our customers receive only the very highest levels of customer service and care. Our internal and external technical and customer service teams are on-hand to provide professional and experienced application advice to enable our customers to apply our products to their particular ventilation and air movement applications. As the USA sales, marketing and distribution division of the Soler & Palau Ventilation Group (S&P) of companies we are committed to providing only the very highest levels of customer service. Our commitment in providing only the very highest standards of customer service is key to our company strategy.

Soler & Palau Ventilation Group is the world’s leading fan manufacturer. It celebrated its 50th anniversary in 2001. S&P is able to offer a range of ventilation products benefiting from over 50 years of experience within the industry. The company’s impressive, long-term growth is the result of one simple philosophy—develop an air-moving product that effectively and efficiently meets the needs of the customer, supported by unparalleled engineering, distribution and service.

In 1951 Eduard Soler and Josep Palau, both born in Ripoll, Spain, founded the company Soler & Palau. From the very start the business proved to be their vocation. Together they combined their extensive knowledge and flair to ensure the successful start of their business project. There is continual in-house product development with state-of-the-art technology, and a continued program of in-house laboratory certifications.

Currently S&P’s R&D, manufacturing and distribution facilities occupy a total of 1.1 million square feet, with offices and locations around the globe. S&P products can be found in virtually any commercial or residential application, ranging from innovative, quiet and reliable room ventilators to large diameter, high capacity exhaust systems designed for critical applications in some of the world’s toughest environments.



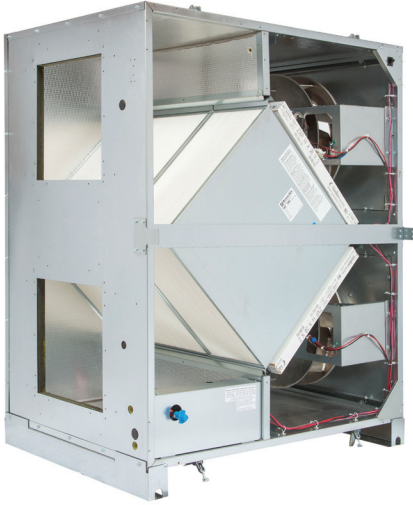

**Ventilation Type:**

Static plate, heat and humidity transfer

**Typical Airflow Range:** 375-1,575 CFM

**AHRI 1060 Certified Core:** One L62-G5 and one L125-G5

**Standard Features:**

- TEFC Premium efficiency motors
- Motor starters
- Non-fused disconnect
- 24 VAC transformer/relay package

**Filters:**

Total qty. 4, MERV 8: (2) 14" x 20" x 2" and (2) 16" x 20" x 2"

**Unit Dimensions & Weight:**

45 1/8" L x 33 1/2" W x 53 5/8" H  
337 lbs.

**Max. Shipping Dimensions & Weight (on pallet):**

70" L x 47" W x 58 5/8" H  
403 lbs.

**Motor(s):**

Qty. 2, 1.0 HP ea., Direct drive motorized impeller packages

MOTOR HP	PHASE	EXTERNAL STATIC PRESSURE (INCHES WATER COLUMN)													
		0.0		0.25		0.50		0.75		1.00		1.25		1.50	
		CFM	WATT	CFM	WATT	CFM	WATT	CFM	WATT	CFM	WATT	CFM	WATT	CFM	WATT
1.0	Single	1,575	1,545	1,470	1,525	1,350	1,500	1,225	1,475	1,090	1,435	950	1,380	795	1,300
1.0	Three	1,675	1,410	1,570	1,400	1,435	1,380	1,280	1,340	1,115	1,280	940	1,210	760	1,135

**Note:** Watts is for the entire unit (2 motors).

**Note:** Airflow performance includes effect of clean, standard filter supplied with unit.

HP	PHASE	V	HZ	FLA PER MOTOR	MIN. CIR. AMPS	MAX. OVERCURRENT PROTECTION DEVICE
1.0	Single	120	60	6.5	14.6	20
1.0	Single	208-230	60	3.3-3.4	7.7	15
1.0	Three	208-230	60	2.2-2.2	5.0	15
1.0	Three	460	60	1.1	2.5	15

### ABBREVIATIONS

EA: Exhaust Air to outside  
 OA: Outside Air intake  
 RA: Room Air to be exhausted  
 FA: Fresh Air to inside

**INSTALLATION ORIENTATION**  
 Unit may be installed in any orientation.

### NOTE

1. UNLESS OTHERWISE SPECIFIED, DIMENSIONS ARE ROUNDED TO THE NEAREST EIGHTH OF AN INCH.
2. SPECIFICATIONS MAY BE SUBJECT TO CHANGE WITHOUT NOTICE.

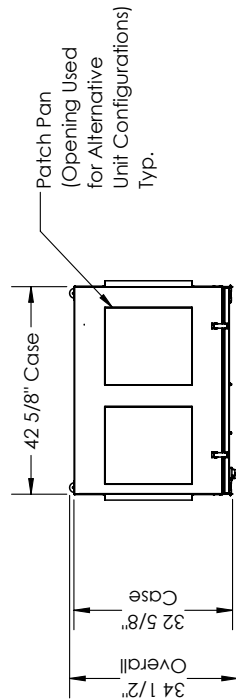

TOP VIEW

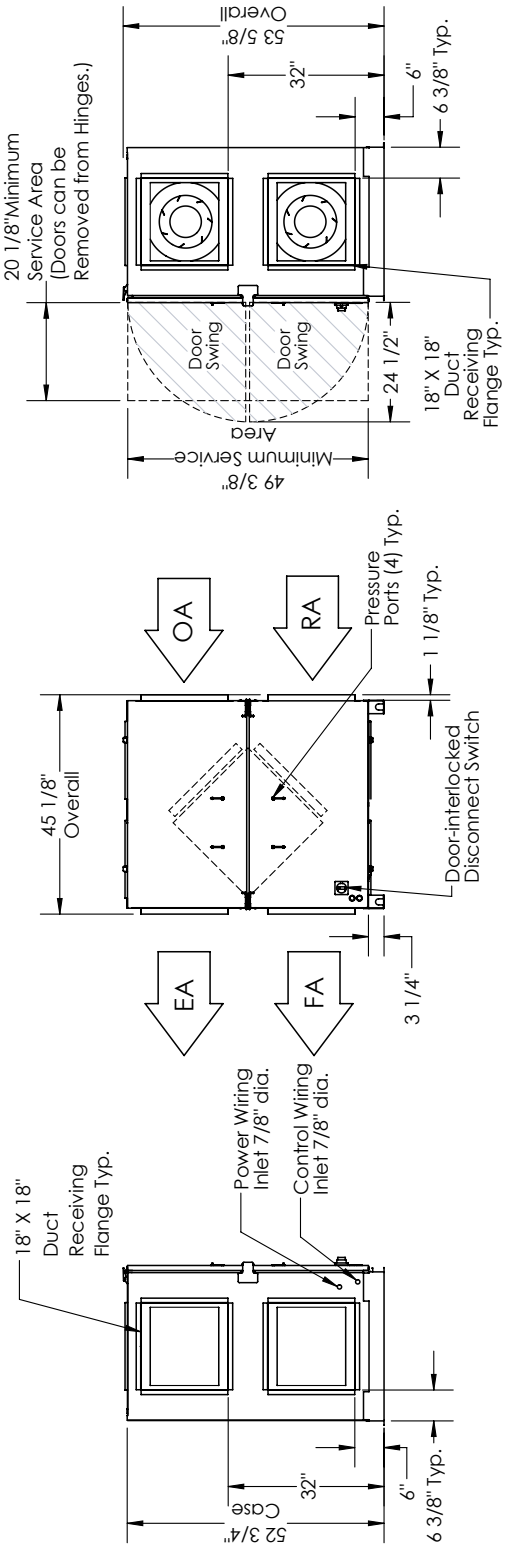

## PLANNING YOUR INSTALLATION

### PLACEMENT OF THE TRC1200

The TRC1200 is designed for installation indoors. Select a location that is central to the inside duct runs, and close to both the exhaust duct (to the outside) and the Supply Air duct (from the outside). The unit can be installed in any orientation but the contractor is responsible for safe installation of the unit.

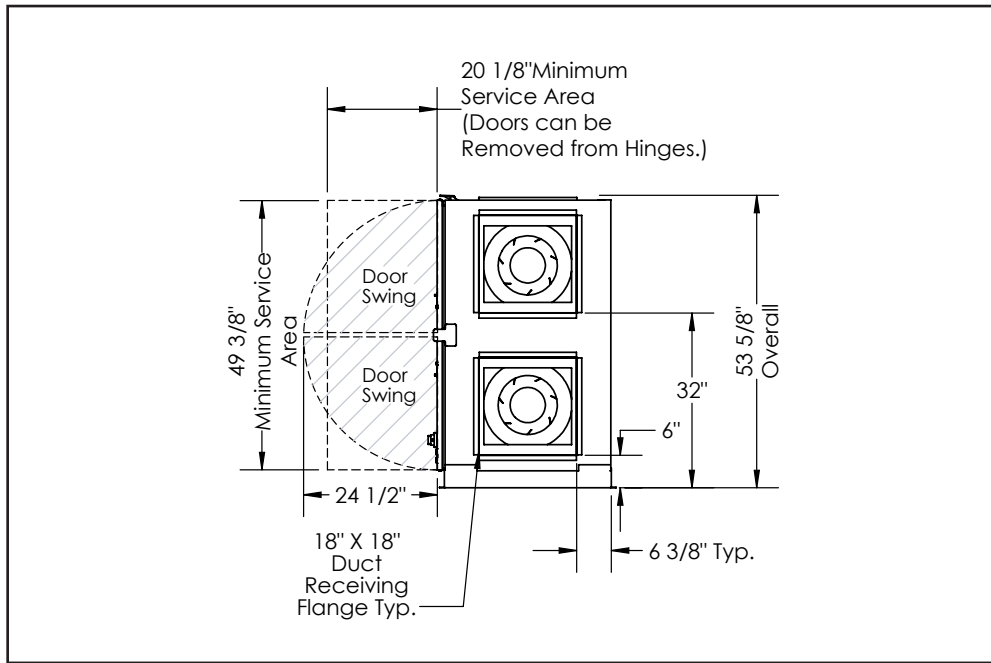
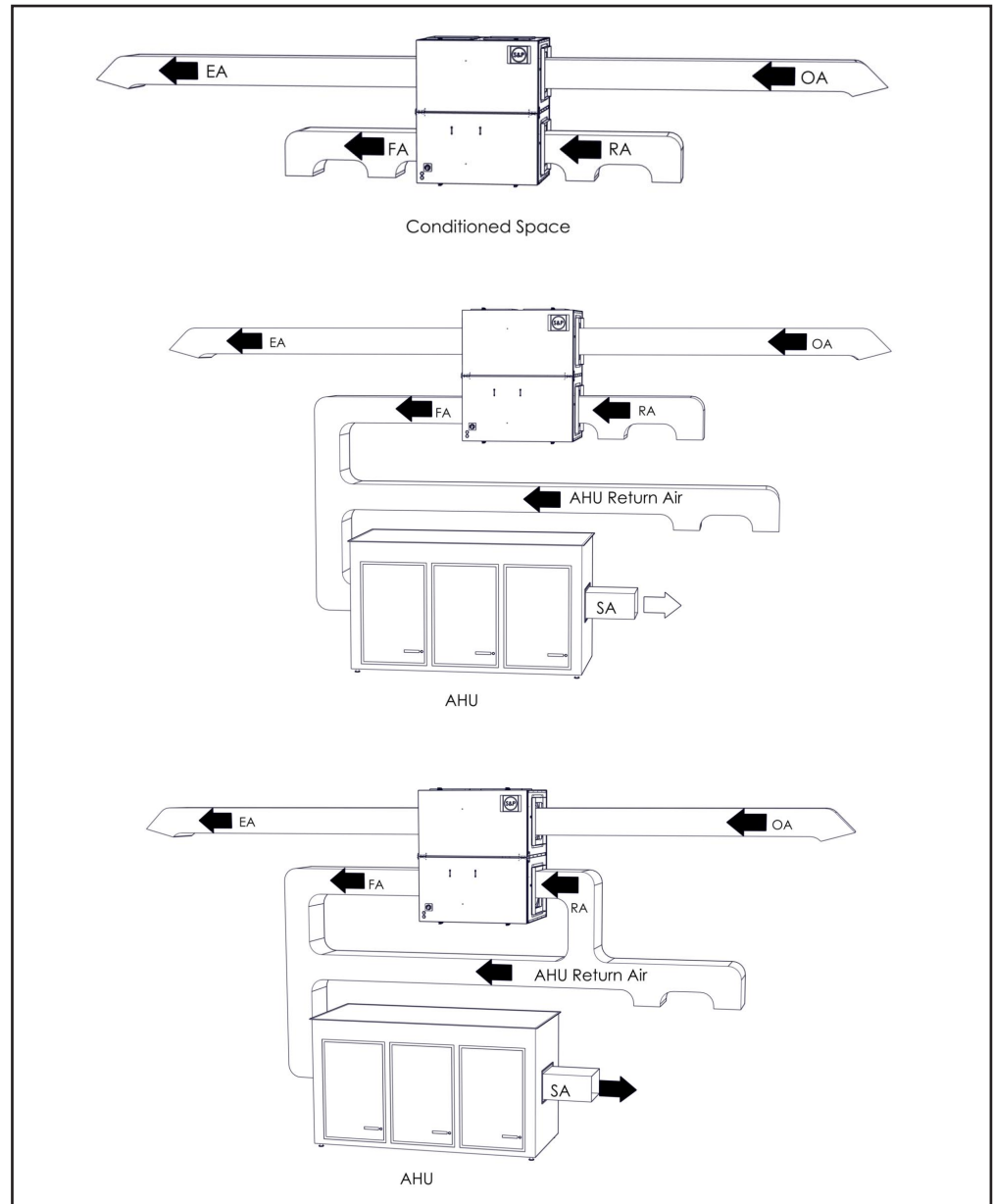

FIGURE F1 SERVICE AREA TRC1200

**APPLICATIONS**

See figure F2 for examples of some common installation approaches.



**FIGURE F2 COMMON INSTALLATION APPROACHES**

**DUCTS TO THE OUTSIDE**

The exhaust outlet and Supply Air inlet on the outside of the building should be at least ten feet apart to avoid cross-contamination.

The exhaust outlet should not dump air into an enclosed space or any other structure. The inlets and outlets should be screened against insects and vermin and shielded from the weather to prevent the entry of rain or snow.

## INSIDE DUCTWORK SYSTEM

### FOLLOW ENGINEER'S DUCTWORK DESIGN

Ductwork should be designed by an engineer to allow the unit to provide the required airflow and reduce pressure drop for efficient, quiet operation.

### AIRFLOW RATES

The airflow rate for both the Supply Air and the Exhaust Air should be roughly equal (or balanced") for best performance of the TRC1200 Unit. See unit specification sheet for CFM/ESP curves.

### DUCT TRANSITIONS

Ducts should enter and exit the unit through smooth, gradual transitions.

### DUCT INSULATION

If the inside ducts run through un-conditioned spaces, they must be insulated, with a sealed vapor barrier on both inside and outside of insulation.

### **⚠ WARNING**

The Supply Air inlet should be at least 10' away from chimneys, furnace and water heater exhausts, and other sources of carbon monoxide, humidity or other contamination. Do not locate the Supply Air inlet where vehicles may be serviced or left idling. Never locate the Supply Air inlet inside a structure.

### RAIN ENTRY PREVENTION

To prevent the entry of rain through the outside air inlet duct, observe the following:

1. Velocity at face of inlet hood should not exceed 500 feet per minute (fpm).
2. Inlet duct must be at least 18" x 18".
3. Centerline length along duct from weather hood to unit inlet must be at least 48".
4. Inlet duct must pitch downward to the outside; centerline of inlet hood must be at least 18" below the centerline of the unit inlet.
5. Outlet duct must pitch downward to the outside with a slope of at least ¼" to the foot.

#### **⚠ CAUTION**

To avoid motor bearing damage and noisy and/or unbalanced blowers, keep drywall spray, construction dust, etc., out of unit.

#### **⚠ WARNING**

RISK OF FIRE, ELECTRIC SHOCK, OR INJURY. OBSERVE ALL CODES AND THE FOLLOWING:

1. Before servicing or cleaning the unit, switch power off at disconnect switch or service panel and lock-out/tag-out to prevent power from being switched on accidentally. More than one disconnect switch may be required to de-energize the equipment for servicing.
2. This installation manual shows the suggested installation method. Additional measures may be required by local codes and standards.
3. Installation work and electrical wiring must be done by qualified professional(s) in accordance with all applicable codes, standards and licensing requirements.
4. Any structural alterations necessary for installation must comply with all applicable building, health, and safety code requirements.
5. This unit must be grounded.
6. Sufficient air is needed for proper combustion and exhausting of gases through the flue (chimney) of fuel burning equipment that might be installed in the area affected by this equipment. If this unit is exhausting air from a space in which chimney-vented fuel burning equipment is located, take steps to assure that combustion air supply is not affected. Follow the heating equipment manufacturer's requirements and the combustion air supply requirements of applicable codes and standards.
7. Use the unit only in the manner intended by the manufacturer. If you have questions, contact the manufacturer.
8. This unit is intended for general ventilating only. Do not use to exhaust hazardous or explosive materials and vapors. Do not connect this unit to range hoods, fume hoods or collection systems for toxics.
9. When cutting or drilling into wall or ceiling, do not damage electrical wiring and other hidden utilities.
10. If installed indoors this unit must be properly ducted to the outdoors.

## SOUND ATTENUATION

Take these simple steps to attenuate noise from the unit:

### OUTSIDE THE BUILDING

Exhaust velocity noise is the primary cause of unit-related noise outside the building. Size the exhaust duct and grille for less than 1000 FPM air velocity. When practical, orient the exhaust air hood to point away from houses or public areas.

### DUCTS

Make sure the ductwork at the unit outlets is stiff enough to resist the flexure and resulting booming associated with system start-up and shut-off.

In general, provide smooth transitions from the ERV's outlets to the duct. The ducts connecting to the outlets should be straight for a sufficient distance, with gradual transitions to the final duct size.

These guidelines are consistent with SMACNA recommended duct layout practices for efficient and quiet air movement. Follow SMACNA guidelines.

### RADIATED NOISE

The TRC1200 is insulated with high-density fiberglass. This provides significant attenuation of radiated sound.

The inlet ducts can be significant sources of radiated sound as well. The OA and RA ducts (inlet ducts) should be insulated for sound control. This insulation should start at the unit. At a minimum the first ten feet of duct should be insulated. All parts of the OA and RA ducts located in the mechanical space should be insulated for sound control, both to minimize sound radiation out of these ducts and also to control sound radiation into the ducts.



## FIELD CONVERSION OF OPENINGS

The TRC1200 is designed to allow field conversion of the unit openings. This means the motorized impeller subassemblies can be moved to an adjacent wall of the unit if that opening is preferred. The outlet openings can also be moved to an adjacent wall.

Before you start, plan the duct work layout:

- Determine which openings are to be converted.
- Turn off the disconnect switch on the unit.
- Make sure electrical power is shut off to the unit and disconnect switch.
- Remove the access doors from the unit.
- Remove the core strap, filters, and energy exchanger cores from the unit.

### TO FIELD CONVERT INLET OPENING

1. Disconnect motor harness connector (A) by the motor. Move the wire harness out of the way if necessary.
2. Support the impeller subassembly. Remove the eight ¼-20 bolts (B) retaining the impeller subassembly plate to the side rails and front and back tabs.
3. Lift the entire impeller subassembly (C) out of the unit and set aside. Leave the rails in the unit.
4. Remove the patch pan (D) from the desired opening.
5. Using the exposed sheet metal cutout, cut the insulation from the desired opening.
6. Seal the edges of the cut insulation to prevent erosion of the insulation edges and having debris in the airstream.
7. Install the patch pan over the undesired opening.
8. Install the insulation in the undesired opening. Seal the insulation.
9. Remove the duct flange from the undesired opening and install it at the desired opening.
10. If both inlet openings are to be converted, repeat Steps 2–9 for the second inlet opening.
11. At this point, if there are outlet openings for conversion, you will want to address them before proceeding with the inlet opening.
12. After converting the outlet openings move the unit floor brackets (E), if necessary, so when the unit is re-oriented the floor brackets support the unit on the floor.
13. Rotate the unit to the desired orientation, if necessary.
14. Install the impeller subassembly into the new inlet opening and fasten with eight ¼-20 bolts to retain to the side rails and front and back tabs. Make sure the motor harness connector is towards the front of the unit.
15. Connect the motor harness.
16. Repeat Steps 14–15 for other impeller subassembly if required.
17. Tidy up any wire harnesses that were moved making sure motor wires are taut and away from the impeller blades.

**TO FIELD CONVERT OUTLET OPENING**

1. Remove the patch pan (F) from the undesired opening.
2. Using the exposed sheet metal cutout, cut the insulation from the desired opening.
3. Seal the edges of the cut insulation to prevent erosion of the insulation edges and having debris in the airstream.
4. Install the patch pan over the undesired opening.
5. Install the insulation in the undesired opening. Seal the insulation.
6. Remove the duct flange (G) from the undesired opening and install it at the desired opening.
7. If both outlet openings are to be converted, repeat Steps 1–6 for the second outlet opening.
8. If inlet openings are being converted return to Step 12 in the “To Field Convert Inlet Opening” instructions.

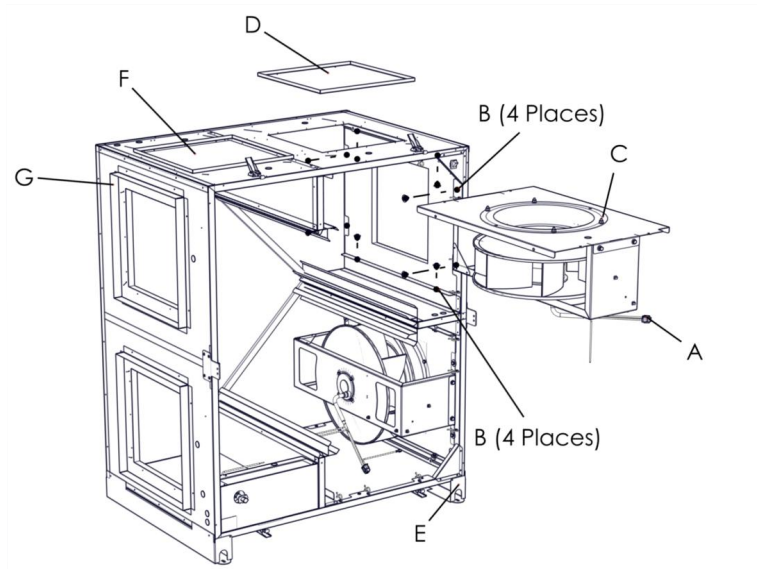

After completion of the field conversion:

- Clean out the interior of the unit to remove any debris.
- Install energy exchanger cores, filters, and core strap.
- Install access doors on the unit.

## INSTALLATION INSTRUCTION

### ACCESSORIES

These ERVs may be ordered with factory-installed features including Isolation Dampers and Electronically Commutated Motors. Consult the supplemental Installation and Operation Manual(s) for these features if supplied.

#### **⚠ WARNING**

Standard TRC1200 with single phase original equipment motors are NOT suitable for use with solid state speed control.

Three phase motors are NOT suitable for use with solid state speed control.

Single phase ECM motors are NOT suitable for use with solid state speed control. They already have speed control built into the motor electronics.

#### **⚠ WARNING**

Secure the TRC1200 with straps or clamps so that it cannot fall or tip in the event of accident, structural failure or earthquake.

#### **⚠ CAUTION**

The TRC1200 weighs 340 lbs. It is the installer's responsibility to make sure that the screws or bolts used for securing the units are properly selected for the loads and substrates involved.

### MOUNTING THE UNIT

The TRC1200 is manufactured with two floor stands for installation at floor level in an upright position. Adequate clearance for the access door latches must be provided.

The TRC1200 may also be hung on the wall or suspended from a ceiling. Screw or bolt mounting straps or brackets directly to the sheet metal case as necessary. Remove the access doors before installing screws—make sure your fasteners do not damage internal parts. Do not screw into the access doors.

Inspect Fans prior to start-up and connecting ductwork, when the TRC1200 unit and fans are installed in the desired orientation, check the gap between wheel and inlet ring—it should be consistent all the way around.

Spin the blower wheel vigorously to confirm it does not rub.

If the inlet ring needs re-adjusting, loosen the 4 bolts and nuts holding the inlet ring and adjust it such that there is a consistent gap between the wheel and inlet ring.

### ELECTRICAL SPECIFICATIONS

Use conduit, strain reliefs, etc. as required by code to secure the field wiring. Electrical knockouts are provided for alternate line voltage and voltage control locations for field wiring to the internal electrical box. If the alternate sites are desired for field wiring then carefully remove the knockout plugs from the alternate sites. Insulate and plug the open knockout locations.



If your unit is equipped with EC Motors, please refer to "EC Motor Manual Supplement" for more detail.

WIRING SCHEMATICS

 Schematics shown are representative of standard units. See Unit Schematic label for detailed information.

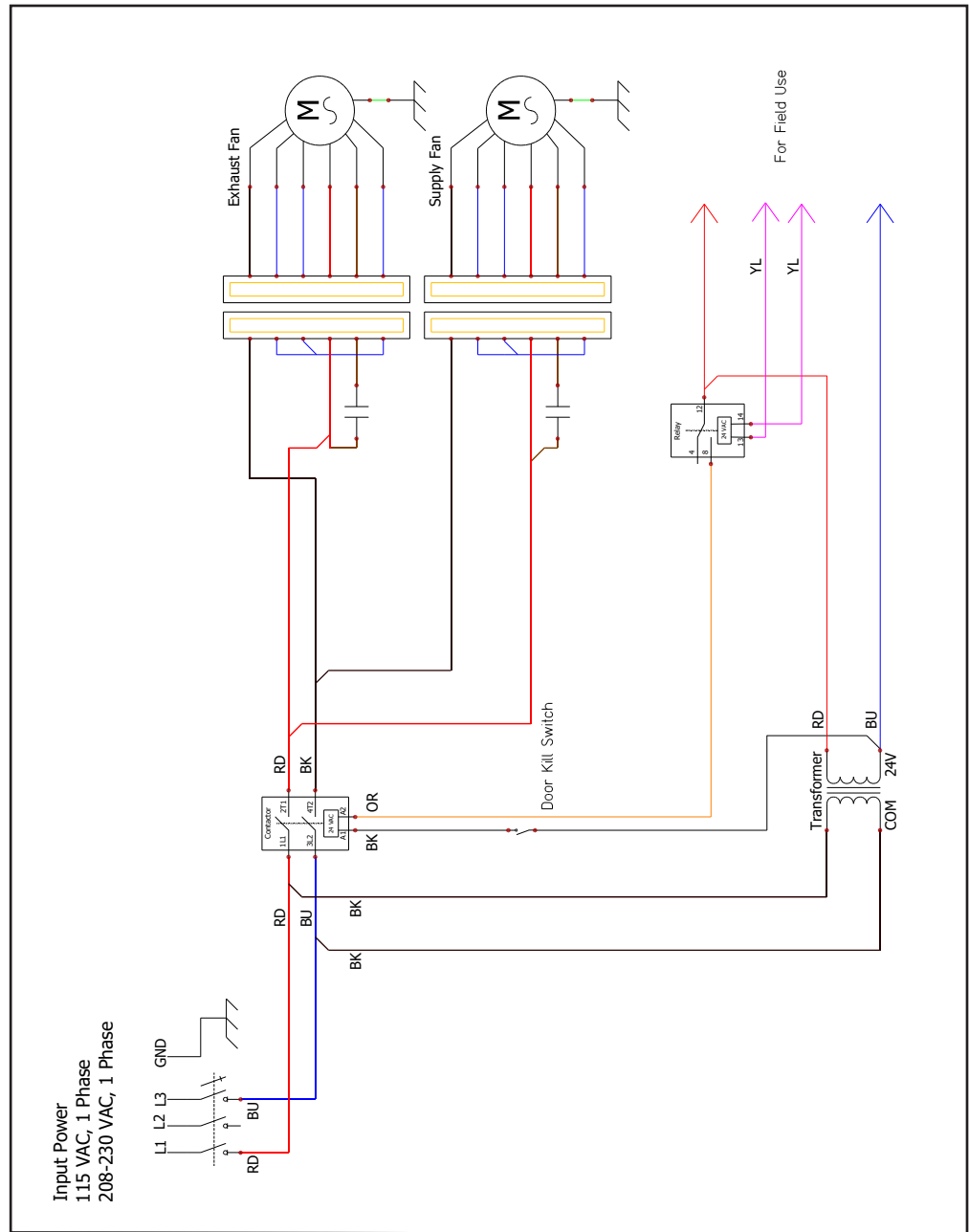

TRC1200 P1 SINGLE PHASE UNIT

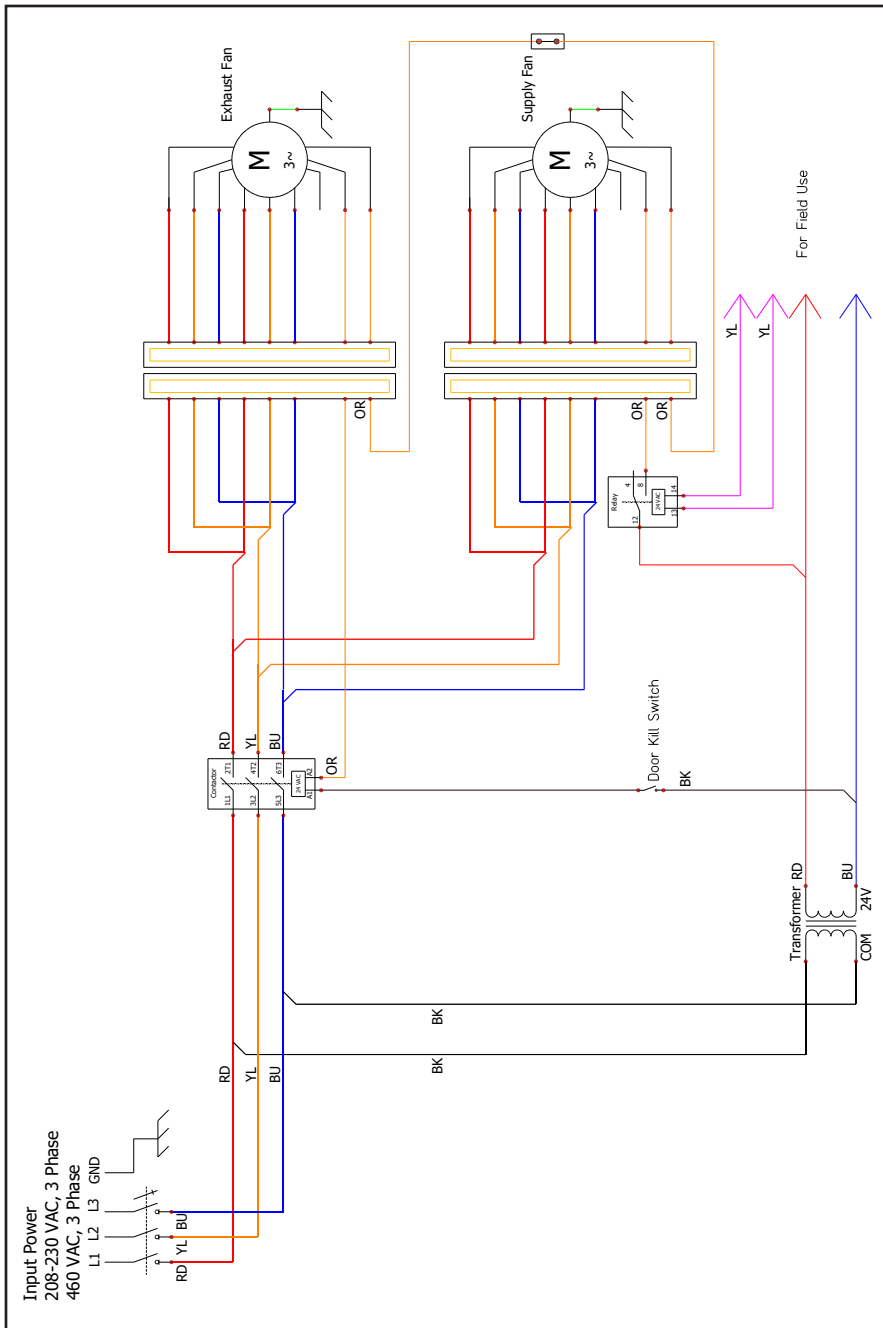

TRC1200 P3 THREE PHASE UNIT

## INSTALLATION INSTRUCTION

### LOW VOLTAGE CONTROL SYSTEM

This ERV is provided with a Class II 24VAC power supply system that operates the unit's contactor(s) for TRC1200. The ERV's 24VAC Power Supply can also be used to power the externally-installed controls system: up to 8VA of power is available.

The unit's power supply system includes isolation relay(s) so you can use external controls whose contact ratings are as low as 50mA (1.2VA). Also, it is possible to operate the isolation relays with 24VAC power from an external source (with proper wiring connections).

A built-in circuit-breaker prevents damage to the transformer and other low-voltage components in the event of a short-circuit or overload. In extreme cases, the transformer itself is designed to fail safely.

#### Specifications

- Nominal Output Voltage under load: 24VAC
- Typical Output Voltage at no load: 29-31V
- Minimum contact rating for connected control device: 50mA (1.2VA)
- Circuit Breaker Trip Point: 3A

### ⚠ CAUTION

1. Connect only to components intended for use with 24VAC power.
2. Do not undersize the low-voltage wires connected to this device. Observe the wire length and gauge limits indicated in this manual.
3. Do not overload this unit's 24VAC power supply system. Confirm that the power requirements of devices you connect to this power supply system do not exceed 8VA in total.
4. If an external source of 24VAC power is used to control the unit, consult the wiring schematics and connect the external power only to the specified terminals in order to avoid damaging the unit or external controls. Connect only CLASS II power to the control terminals of this unit.
5. Unit is not equipped to receive analog signals (such as 1-10vdc or 4-20mA).
6. Unit is not equipped to communicate directly with building management systems (such as BACnet, LONWORKS, etc.). However, the unit can be controlled by powered or non-powered contacts operated by any kind of control system.

### HOW TO RESET THE 24VAC CIRCUIT BREAKER

If the transformer is subjected to an excessive load or a short circuit, the circuit breaker will trip to prevent the failure of the transformer. When it trips the circuit breaker's button pops up. Shut off the primary-side power to the unit, and remove the excessive load or the short. The circuit breaker can be reset about fifteen seconds after it trips by pressing in the button.

### LIMITS OF POWER OUTPUT

If limits on wire gauge and length are observed, you may connect control devices that draw up to 8VA to the blue and red wires. More than one device can be connected as long as total steady-state load does not exceed 8VA.

### IMPORTANT

If primary-side voltage is 230VAC, move black primary-side lead from transformer's "208V" terminal to the transformer's terminal marked "240V" ("230V" in some units).

Do not move the black primary-side lead that is connected to the transformer's "COM" terminal.

**OBSERVE THESE LIMITS TO WIRE LENGTH AND GAUGE**  
in order to ensure reliable operation of the control system.

Wire Gauge	#22	#20	#18	#16	#14	#12
Circuit Length	100'	150'	250'	400'	700'	1000'

"Circuit Length" is distance from ERV to control device.

**CONTROL WIRING SCHEMATICS**

**CONTROL WIRING EXAMPLES BY TYPE OF APPLICATION**

A. Single 2-wire Control, Unpowered:

Use schematic below if the control requires no power from the unit to operate and acts like a simple on/off switch. The control must not supply any power to the ERV unit. Install jumper (provided) between terminals 2 and 3. Connect the control's contacts to terminals 1 and 4 to operate the ERV's Isolation Relay for OA/SA Blower. Install jumper between terminals 4 and 5 to operate the ERV's Isolation Relay for the RA/EA Blower.

Single 2-wire Control on Separate Power Supply, No Power Present at Control Output:  
Wire as shown for the Single 2-wire control (A. above).

**NOTE:** The simplified schematics below show only the relevant portions of the low-voltage control circuit in the ERV unit and representational external control approaches. See the complete unit wiring schematics elsewhere in this manual.

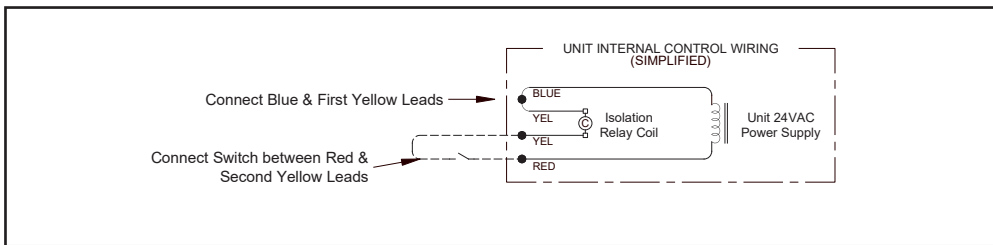

**FIGURE A SWITCH OR NON-POWERED CONTROL USING UNIT'S 24VAC POWER SUPPLY**

B. Control Sending 24VAC "On" Signal (from an external power source) to ERV: Make sure the blue and red leads are separately capped and not connected to any other wires. Now you safely can apply 24VAC to the two yellow leads to operate the ERV's isolation relay.

**CAUTION**  
External control system should not draw more than 8VA.

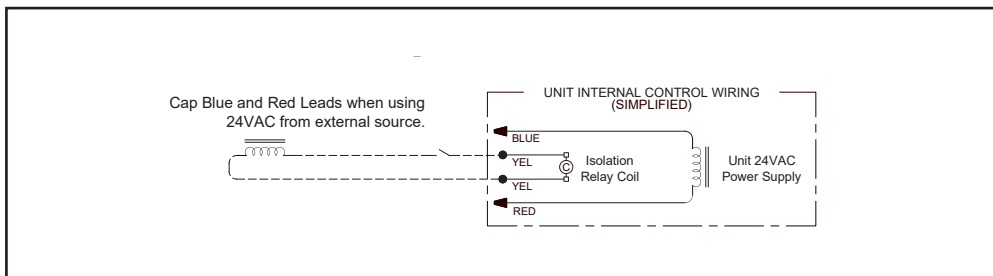

**FIGURE B 24VAC FROM AN EXTERNAL SOURCE**

 **NOTE:** Be sure to remove cap from pressure port before inserting tubing. Insure tubing is well seated in pressure ports.

 **NOTE:** The tubing should extend in the pressure port approx. 1 inch.

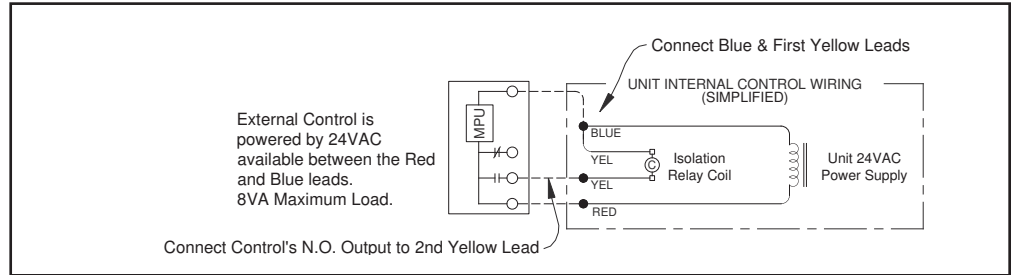

**FIGURE C AN EXTERNAL CONTROL DEVICE USING UNITS 24 VAC POWER SUPPLY**

C. Control operating on Unit's 24VAC Power Supply:  
 24VAC power is available at the blue and red leads. Connect one of the yellow leads to the blue lead. Connect the switched output of the Control to the red lead to operate the ERV's isolation relay.

### CAUTION

Be careful if the external control system provides 24VAC power at its control output: make sure blue and red leads are separately capped and not connected to any other wires.



## MEASURING AIRFLOW

### EQUIPMENT REQUIRED

- A magnehelic gauge or other device capable of measuring 0 to 1.5 in. water of differential pressure.
- 2 pieces of natural rubber latex tubing, 1/8" ID, 1/16" wall works the best.

### CROSS CORE STATIC PRESSURE MEASUREMENT INSTRUCTIONS

The individual differential static pressures (DSP) can be measured using the installed pressure ports located in the front of the units core access doors.

To read SCFM of Supply Air (SA) install the "high" pressure side (+) of your measuring device to the Outside Air (OA) port and the "low" pressure side (-) to the Supply Air (SA) port.

- To read SCFM of Room Air (RA) install the "high" pressure side (+) of your measuring device to the Room Air (RA) port and the "low" pressure side (-) to the Exhaust Air (EA) port.
- Use the reading displayed on your measurement device to cross reference the CFM output using the conversion chart.

 NOTE: These ports have been carefully located on the unit as to give you the most accurate airflow measurement. Do not relocate pressure ports.

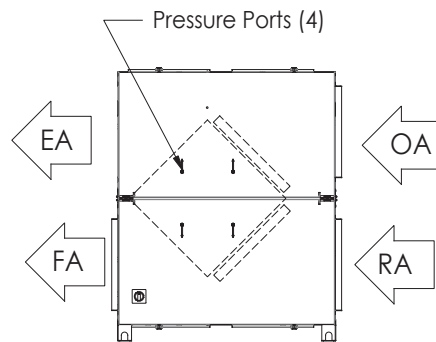



FIGURE F3 AIRFLOW DIAGRAM TRC1200

DIFFERENTIAL STATIC ACROSS CORE DSP VS. CFM													
TRC1200		DSP	0.15	0.20	0.25	0.30	0.35	0.40	0.45	0.5	0.55	0.60	0.65
		Supply Air (SA)	CFM	380	500	620	740	860	980	1095	1215	1330	1450
	Room Air (RA)	CFM	320	440	565	695	825	960	1095	1235	1375	1515	-

 NOTE: Pressure drop of clean 2" MERV-8 Filters is included in the Unit Performance Ratings Table.

**FILTER SPECIFICATIONS**

- (2) 14" x 20" x 2" and (2) 16" x 20" x 2" (nominal) pleated filters. Actual size: 13.5" x 19.5" x 1.75" and 15.5" x 19.5" x 1.75".
- Optionally (4) 15" x 20" x 2" (nominal) pleated filters can be used. Actual size: 14.5" x 19.5" x 1.75".

 NOTE: Pressure drop of standard filter supplied is included in unit airflow performance tables.

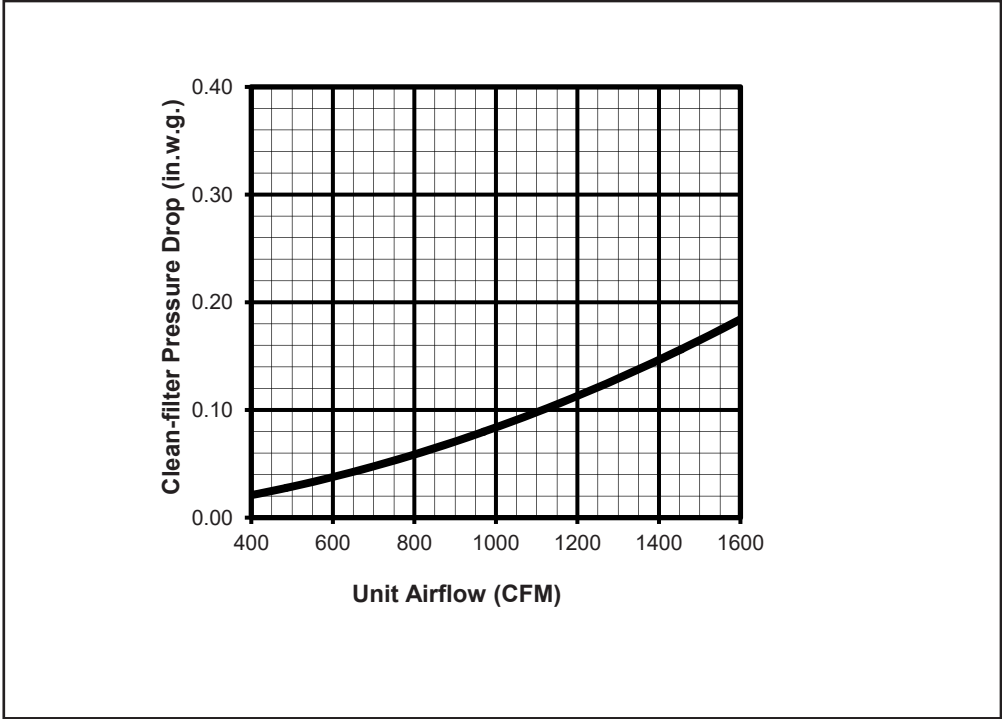

**INITIAL PRESSURE DROP OF MERV 8 FILTERS SUPPLIED WITH THIS UNIT**

**SERVICE PARTS**

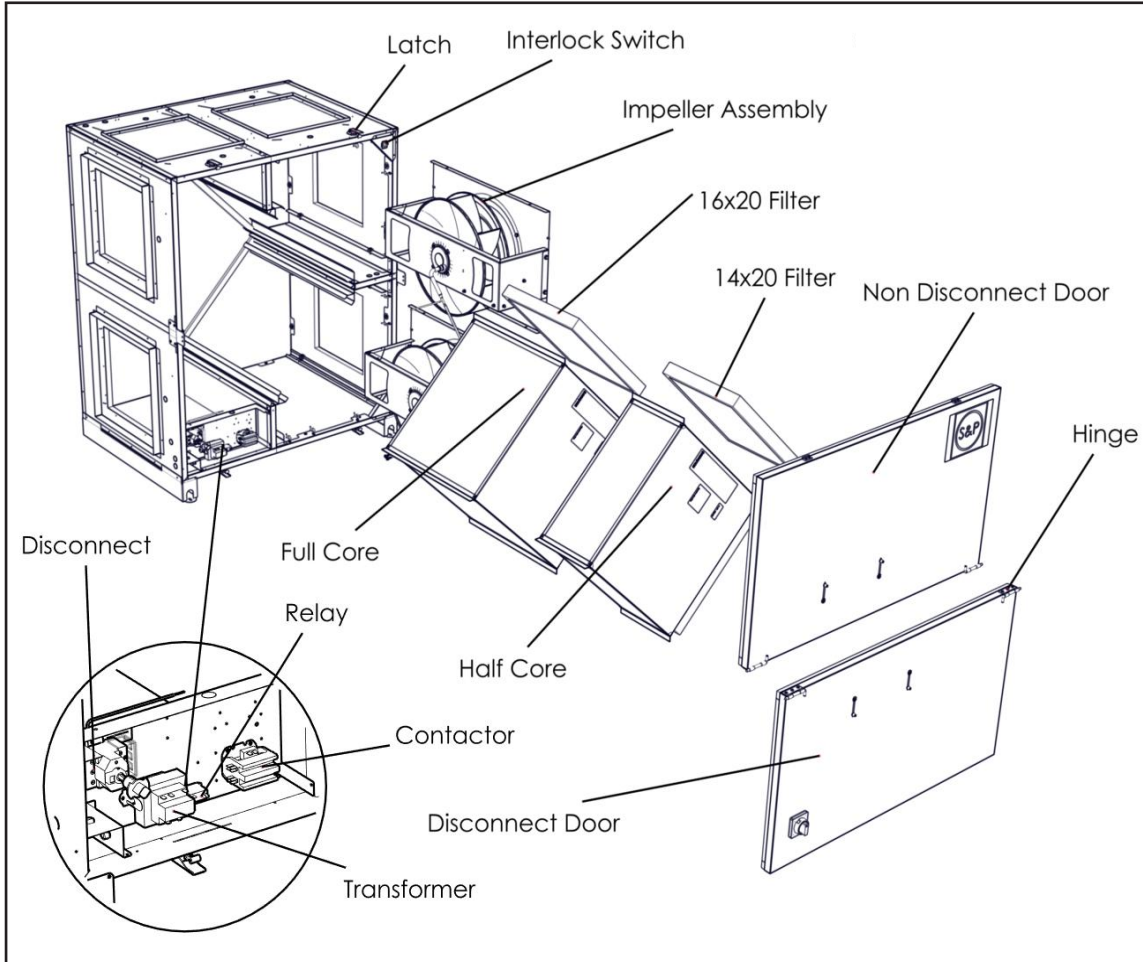

**TRC1200 SERVICE PARTS**

**MAINTENANCE REQUIREMENTS**

**⚠ WARNING**

DANGER OF ELECTRICAL SHOCK WHEN SERVICING AN INSTALLED UNIT.  
 ALWAYS DISCONNECT POWER SOURCE BEFORE SERVICING! More than one disconnect switch may be required.  
 Proper wiring size selection and wiring installation are the responsibility of the electrical contractor.



**NOTE:** The filters supplied in the unit are usually able to keep the energy exchange core clear for several months. Finer filters can be used but must be cleaned more often. If using finer filters, their increased resistance to flow must be allowed for in the system design.

**TO CLEAN THE ENERGY EXCHANGE ELEMENT**

Vacuum the face of the energy exchange element yearly. Dust collects only on the entering face of the energy exchange element, right where the filter sits. The interior of the energy exchange element stays clean even if the element faces are dust covered. The core airflow paths are designed to transport the air in a laminar motion. The core flutes move the air in a laminar airflow such that particulate deposition is maintained at virtually nil.

1. Remove the filters.
2. Vacuum the exposed faces of the energy exchange core with a soft brush.
3. Vacuum out dust from the rest of the unit case.
4. Install new filters.

**⚠ CAUTION**

DO NOT WASH THE ENERGY EXCHANGE CORE.  
 Keep it away from water or fire to avoid damaging it. Always handle the core carefully.  
 Filters must be used or the energy exchange core will become blocked by dust and reduce unit efficacy. In extreme cases components may be damaged.

**INSPECT AND CHANGE THE FILTERS REGULARLY**

Inspect and/or replace filters every two or three months when the unit is in regular use, or as needed.

1. To access the filters unlatch the access doors. The access doors may be removed.
2. Pull the dirty filters out and replace with new filters.



## MOTOR MAINTENANCE

The motor needs no lubrication. If necessary vacuum clean the blower wheels at the same time you clean the face of the energy exchange element (annually).

### **⚠WARNING**

RISK OF INJURY OR DAMAGE.

Motor has an automatic reset thermal protector. Disconnect power before servicing or resetting motor thermal protector. Use caution, motor may be hot. The motor must cool before it resets the thermal protector.

If the motor thermal protector tripped, correct the issue that caused the motor to overheat (e.g. over motor rated amperage or locked rotor).

### **⚠WARNING**

Don't allow the access door to drop when unlatched. Injury to personnel or damage to unit may occur.

Keep fingers away from between the access doors when unlatching and opening the doors. Potential PINCH POINT.





# S&P USA VENTILATION SYSTEMS

Enabling the World to Breathe Better Air



**ADVANCING  
VENTILATION®**

## **S&P USA VENTILATION SYSTEMS, LLC**

6393 Powers Avenue  
Jacksonville, FL 32217  
SolerPalau-USA.com  
800.961.7370

## **S&P CANADA VENTILATION PRODUCTS, INC.**

6710 Maritz Drive, Unit 7  
Mississauga, ON L5W 0A1, Canada  
SolerPalauCanada.com  
416.744.1217

---

Soler&Palau  
Ventilation Group



147678\_000 (08/24)