

JencoFan

ECM-MSPD

Installation, Operation, and Maintenance Manual

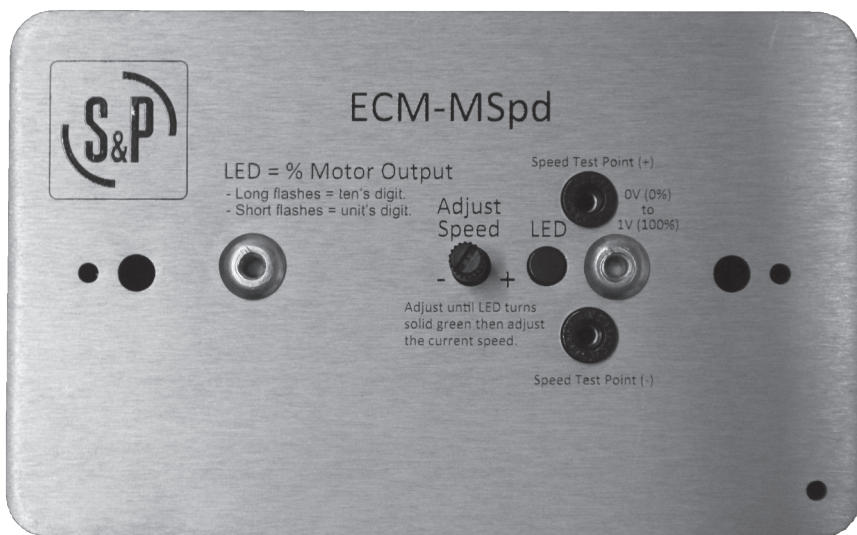

READ AND SAVE THESE INSTRUCTIONS

The purpose of this manual is to aid in the proper installation and operation of fans manufactured by JencoFan. These instructions are intended to supplement good general practices and are not intended to cover detailed instruction procedures, because of the wide variety and types of fans manufactured by JencoFan.

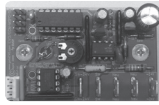

EC Motor Control

1. APPLICATION

The ECM-MSpd allows switches, ~24V thermostats and ~24V controls to select one of two adjustable speed indexes for an EC Motor.

A single diode-multiplexed switch allows up to two speed settings. The speed for each setting can be adjusted when it is activated. The adjustment range is from Off to 100% of the motor's programmed control range.

When changing speeds, the ECM-MSpd control adjusts the speed index¹ at a gradual 1% per second rate. This ramping feature reduces occupant awareness of changes in diffuser airflow.

2. FEATURES

- Isolated Diode-Multiplexed Switch
- PWM or 0 to +10V Output
- Gradual or Fast Speed Change
- Pilot Pulse Enable/Disable

3. ORDERING

PART ID	DESCRIPTION
EVO/ECM-MSPD	Circuit Board Version

4. SPECIFICATIONS

Power	~24V $\pm 20\%$ 50/60 Hz NEC UL 1310 Class2 ^{USA}
	+24V NEC Class II ^{USA}
	2 W, 4 VA + 1VA/Motor
Switch	1k8 Ω load
Speed Selection (see wiring)	<i>Two Speed</i> Only +24V $\pm 20\%$
OUTPUTS	
Motor Control	<i>no jumper</i> PWM ² +15V @ 10 mA (See Options)
	<i>with jumper</i> 0 to +10 V DC @ 10 mA (See Options)
	PWM ² Supports Pilot Pulse (Autoswitch) Function
Therm. Stability	<0.0%/°F
Operating Environment	0°F to 130 °F (-18°C to 55°C) 10-80% rh
Connections	1/4" Tabs

¹ Speed Index = %PWM
except at the end points

² PWM = Pulse Width Modulation

5. ADJUSTMENT

For accurate speed adjustment, a volt meter is required to read the percent voltage.

JencoFan

0 to +1V = 0 to 100% PWM

Example: for an 1800 RPM motor, 0.50V = 900 RPM

Notes:

Ramping is temporarily disabled in the adjustment mode.

Verify with manufacturer on motor minimum speeds as motor will not turn below minimum speeds.

Single Speed Adjustment (No Switch Installed)

1. Insert volt meter probe into the "Speed Test" ports.
2. Enter the speed adjustment mode by rotating the "Adjust Speed" shaft until the flashing LED turns solid green.
3. While in speed adjustment mode, continue to turn the shaft to the desired speed using the percent voltage value as a reference.
4. Once desired speed is reached, the speed setting will be saved after eight seconds. This is noted when the solid LED returns to flashing.

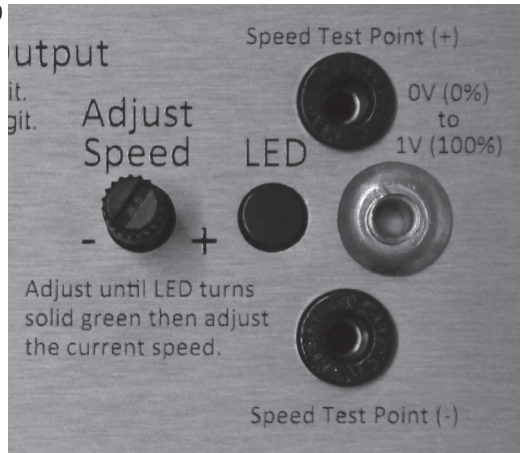

Dual Speed Adjustment (Switch is Installed)

1. Insert volt meter probe into the "Speed Test" ports.
2. Turn switch to "ON" position.
3. Enter the speed adjustment mode by rotating the "Adjust Speed" shaft until the flashing LED turns solid green.
4. While in speed adjustment mode, continue to turn the shaft to the desired speed using the percent voltage value as a reference.
5. Once desired speed is reached, the speed setting will be saved after eight seconds. This is noted when the solid LED returns to flashing.
6. Turn switch to "OFF" position and repeat steps 3-5.

6. Green LED

The **green LED** continuously indicates the speed. After a pause, the lamp flashes out the tens digit, then the units digit of a number between 0 and 100. Long flashes represent the tens digit, and short flashes represent the units digit. For example, a speed of 23% flashes two longs, then three shorts. Two extra-long flashes indicate a speed of 0. An extra-long flash and ten short flashes indicates a speed of 100%. The lamp flashes the speed that was present when the flash sequence started.

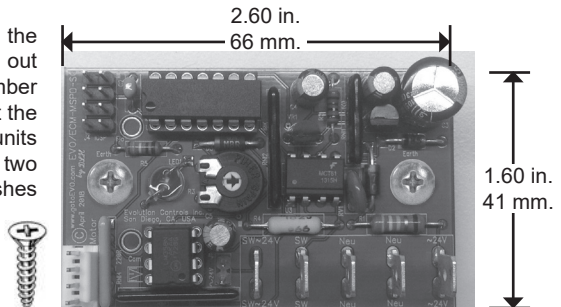

The lamp stops flashing and stays lit when in adjustment mode.

7. MOUNTING

Mount the control inside a metal control cabinet or enclosure. Fasten the control mounting posts to an earthed metal surface. Use #8 flat or oval head screws through the two metallic mounting posts. The countersink taper forces a good earth connection between the mounting post and the PC board. Mounting posts are 3/32" (2.38 mm) ID. Adjustment shafts are .20" (5 mm) dia.

Mount the control with clearance for the ~24V power wires and control cable connector. Mount the control so the green LED is visible. Make sure there is access to the test points and the Adjust shaft.

8. OPTIONS

OPTIONS	DESCRIPTION
Power Supply	Insert jumper when the controller and the call signals share the same power supply. Remove jumper when controller and call signals are powered by different transformers (see Wiring).
Jumper Block J4	N/A
Pilot Pulse	Insert jumper so the PWM never goes below 0.4% or above 99.6%. Some profiles allow the motor to run in an alternate mode when there is no pulse on the PWM input.
Output Type	Insert jumper for 0 to +10V motor control. Remove jumper for PWM motor control
Ramp Disable	Insert jumper to disable the 1% PWM/second ramp rate (no delay).

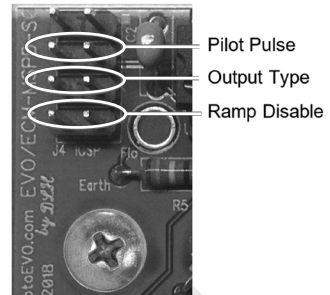
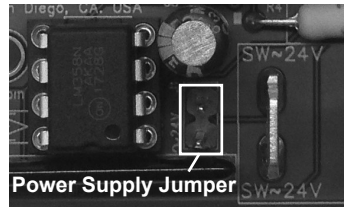

9. WIRING

Power the ECM-MSpd controller with a ~24V NEC UL 1310 Class 2 USA power source. DC voltages from +20V to +30V may also be used to power the control. Observe all code requirements and follow all safety practices regarding low voltage power supplies and circuits to insure a safe, reliable installation.

Earth one side of the power source. Connect the neutral connection to the earthed side of the ~24V Class 2 power source.

Some applications may require an isolated power supply or alternative earthing scheme. Follow code requirements and observe all safety practices concerning unearthed low voltage circuits.

Connect the ~24V connection to the hot side of the ~24V Class 2 power source. You may interrupt this connection to turn off the controller and stop the EC Motor. This is especially useful if you plan to set a flow when the switch is off (no signal at the Switch tab). Many automation controllers will power the ECM-MSpd controller directly from an on/off output.

The Switch tab is optically isolated from other ECM-MSpd circuitry. To use the same power as the control, install the ~24V jumper to internally connect SW~24V to the internal ~24V power.

For simple two speed operation, install the ~24V jumper and connect a switch between SW~24V and SW.

³ If DC voltage is used to power the control and the switch, it can only be used for dual speed control. For multiple speeds, a second ~24VAC transformer must be used to power the switch.

10. SINGLE SPEED

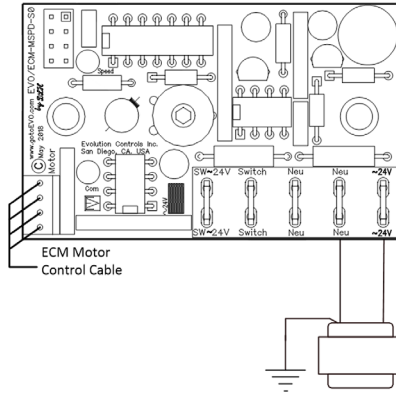

11. DUAL SPEED

Same ~24V Supply (insert Jumper )

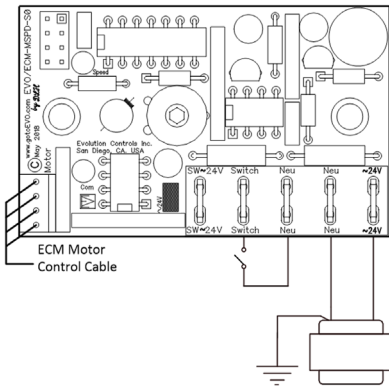

Different ~24V Supplies:

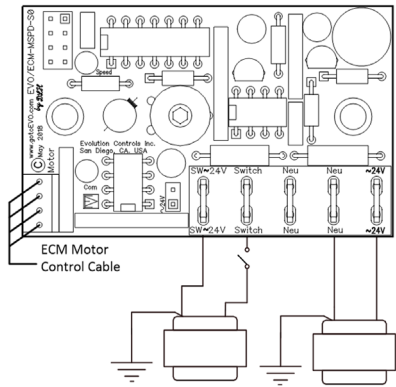

ECM-MSPD WIRING DIAGRAM NIDEC MOTOR

--- FIELD WIRING
— FACTORY WIRING

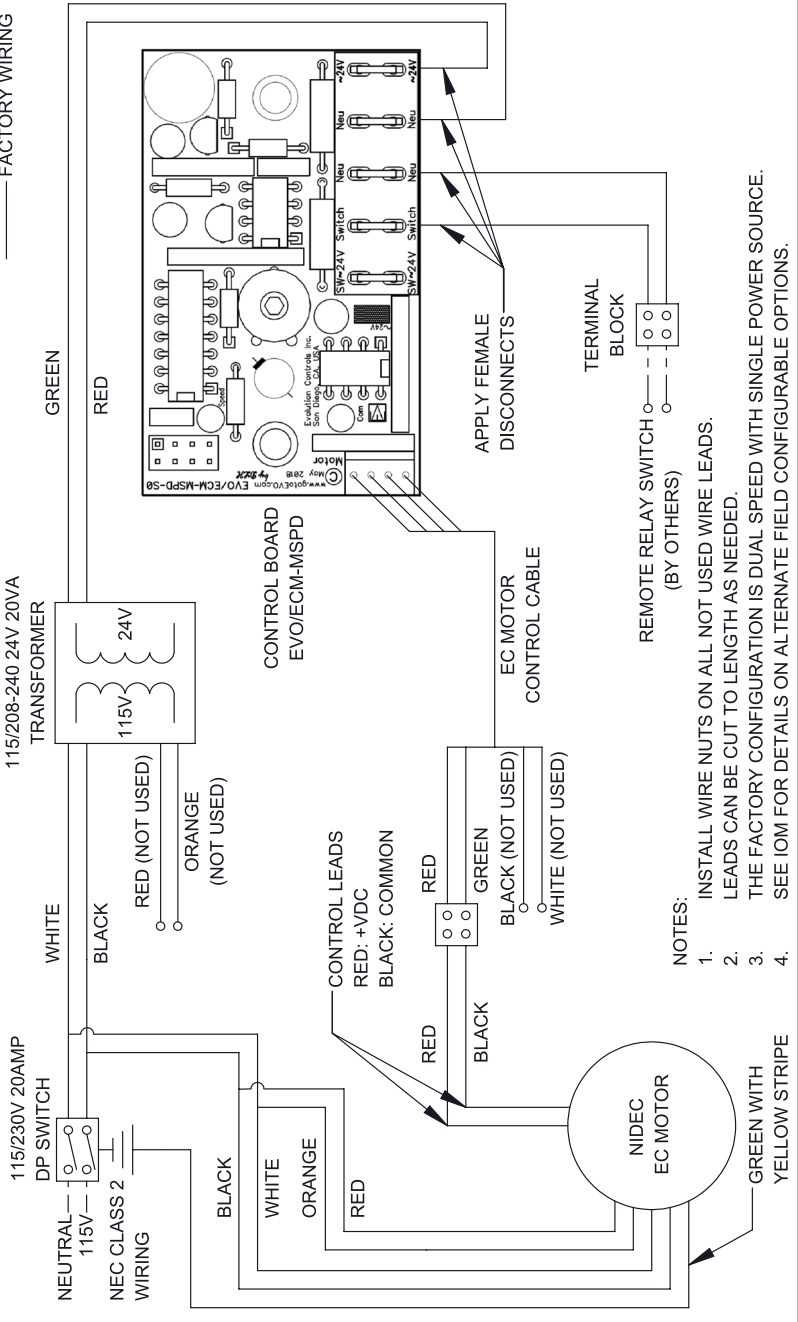

NOTES:

1. INSTALL WIRE NUTS ON ALL NOT USED WIRE LEADS.
2. LEADS CAN BE CUT TO LENGTH AS NEEDED.
3. THE FACTORY CONFIGURATION IS DUAL SPEED WITH SINGLE POWER SOURCE.
4. SEE IOM FOR DETAILS ON ALTERNATE FIELD CONFIGURABLE OPTIONS.

ECM-MSPD WIRING DIAGRAM REGAL BELOIT MOTOR

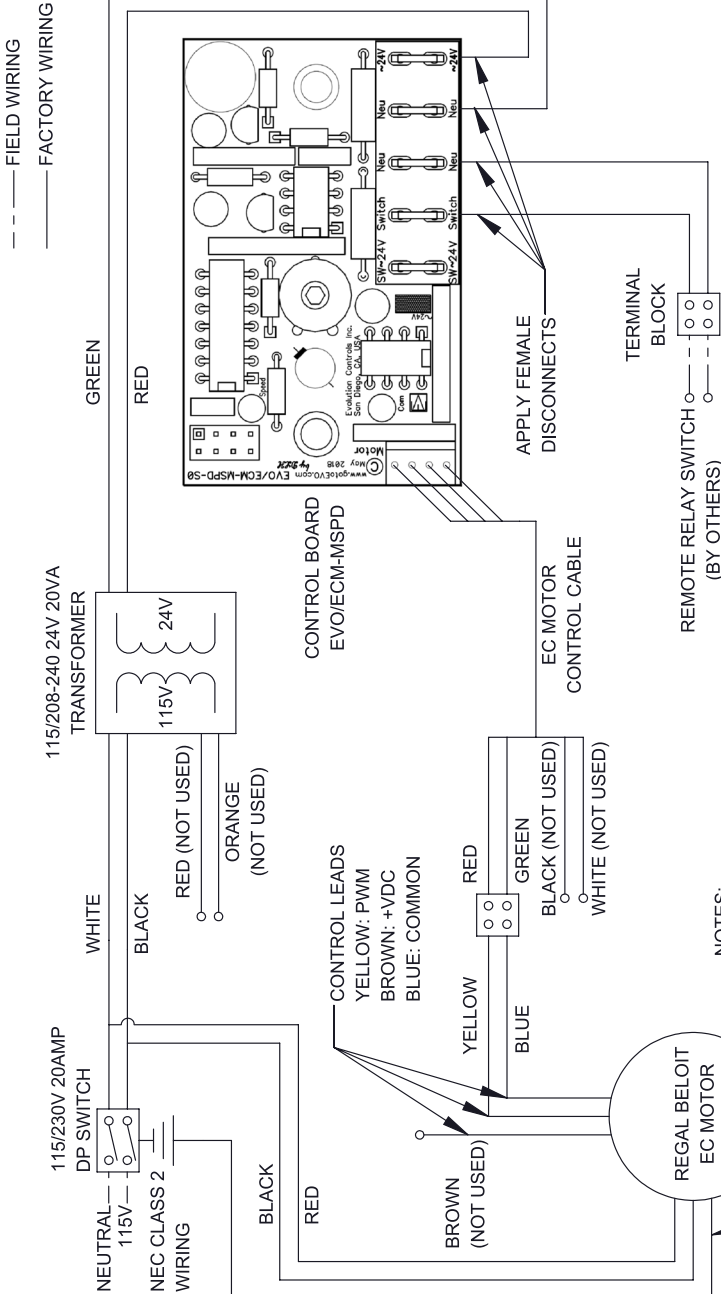

NOTES:

1. INSTALL WIRE NUTS ON ALL NOT USED WIRE LEADS.
2. LEADS CAN BE CUT TO LENGTH AS NEEDED.
3. THE FACTORY CONFIGURATION IS DUAL SPEED WITH SINGLE POWER SOURCE.
4. SEE IOM FOR DETAILS ON ALTERNATE FIELD CONFIGURABLE OPTIONS.

JencoFan

USA Division

6393 Powers Avenue
Jacksonville, FL 32217
P. 904-731-4711 · F. 904-737-8322
www.jencofan.com

Canada Division

6710 Maritz Drive Unit #7
Mississauga, ON L5W 0A1 - Canada
P. 416-744-1217 · F. 416-744-0887
www.jencofan.com