

Features and Construction

- Brushless DC Motor for long life - rated for 60,000 hours
- Built-in backdraft damper
- Robust steel housing
- Attractive, sturdy grille
- ETL Listed
- ENERGY STAR® qualified
- HVI Certified
- 6 year warranty



Performance and Dimensions

PCD200	
CFM @ 0.1" SP	220
CFM @ 0.25 SP	189
Sones @ 0.1" SP	2.5
Sones @ 0.25" SP	N/A
Watts @ 0.1" SP	31.3W
Watts @ 0.25" SP	N/A
ENERGY STAR Qualified	Yes
Duct Connector Diameter (in)	6"
Grille Size (in)	15" x 16"
Dimensions (w x d x h) (in)	12-7/8" x 12-1/2" x 7-5/8"

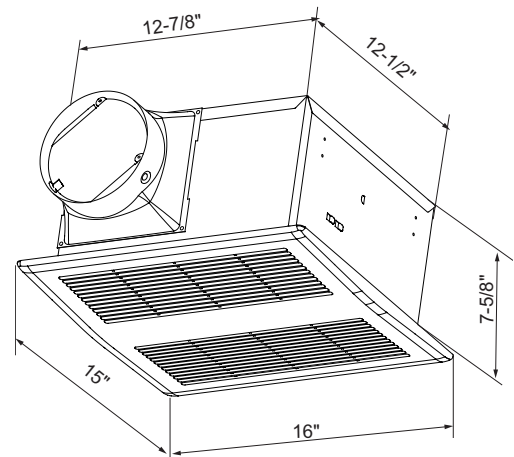

JencoFan, Div. of Soler & Palau Ventilation Group, certifies that the Models PC shown herein are licensed to bear the AMCA Seal. The ratings shown are based on test and procedures performed in accordance with AMCA Publication 211 and AMCA Publication 311 and comply with the requirement of the AMCA Certified Ratings Program.