

MODELS GED/GSD, eGED/eGSD, DFE/DFS, DDE/DDS
 DIRECT DRIVE SIDEWALL PROPELLER FANS

LINE OVERVIEW



JencoFan's Direct Drive Sidewall Propeller Fan line is designed to exhaust or supply large volumes of air at relatively low static pressures. With 3 types of construction, the direct drive models are designed for use in a variety of applications for commercial, industrial and agricultural buildings such as manufacturing and assembly plants, warehouses, parking garages, gymnasiums, equipment rooms, distribution centers, foundries, boiler rooms, greenhouses and OEM applications. The direct drive models provide general ventilation for a wide variety of buildings and enclosed areas within buildings. Examples include factories, assembly plants, warehouses, gymnasiums, garages, jails, machine rooms and many others.

These Sidewall Propeller Fans are rated from 300 to 55,000 CFM with static pressures to 1" w.g. Models range from 10 to 60". A full line of accessories is available to meet any need or specification. See the below Model Comparison to find the right Direct Drive Sidewall Propeller Fan for your application.

Model GED is available in our Quickship program. Most sizes are available for next day or 10-day shipping from stock.



MODEL COMPARISON

Construction Type	Model	Size Range	Performance
	GED GSD	10 to 20"	300 to 3,500 CFM up to 3/4" w.g.
	DFE DFS	10 to 30"	500 to 12,000 CFM up to 1" w.g.
	DDE DDS	24 to 60"	3,500 to 55,000 CFM up to 1" w.g..

MOUNTING ARRANGEMENT OPTIONS

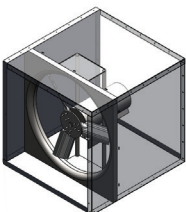
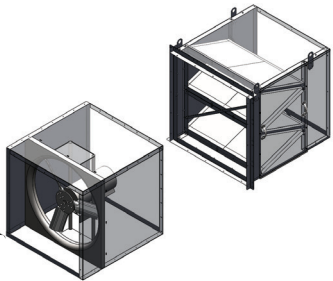
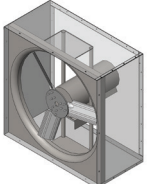
Mounting Arrangement	Description
<p>Wall Housing</p> 	<p>Heavy-gauge, all galvanized G-90 steel housing provides a simple solution to installing a fan and all required accessories in a rough wall opening. It can be used in exhaust or supply applications and in fan sizes 10 through 60 inch.</p>
<p>Filtered Wall Housing</p> 	<p>For installations where filtering is required. Heavy-gauge, all galvanized G-90 steel filtered wall housings are available in both supply and exhaust configurations. They are available in nine (9) sizes for fans ranging from size 14 to 60 inches. They are designed with the draw-thru concept to achieve the highest filter and fan efficiencies.</p>
<p>Wall Collar</p> 	<p>Heavy-gauge, all G-90 galvanized mounting collar provides a simple solution to installing a fan in a rough wall opening when a rear safety guard is NOT required.</p>

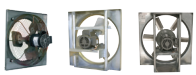

WALL HOUSING MOUNTING OPTIONS

WALL HOUSING: This heavy-gauge, all galvanized G-90 steel (aluminum optional) housing provides a simple solution to installing a fan and all specified accessories in a rough wall opening. It can be used in exhaust or supply applications and maintains the proper clearance between the fan and damper. Depending on space and maintenance requirements, the wall housing may be installed projecting inside or outside of the building. All housings ship assembled with the fan to lessen job site installation costs. Wire motorside guard, damper or propeller side guard and rainhood may be attached to the flange. We strongly recommend a rainhood and motorized shutter for all supply applications and whenever additional weather resistance is desired.

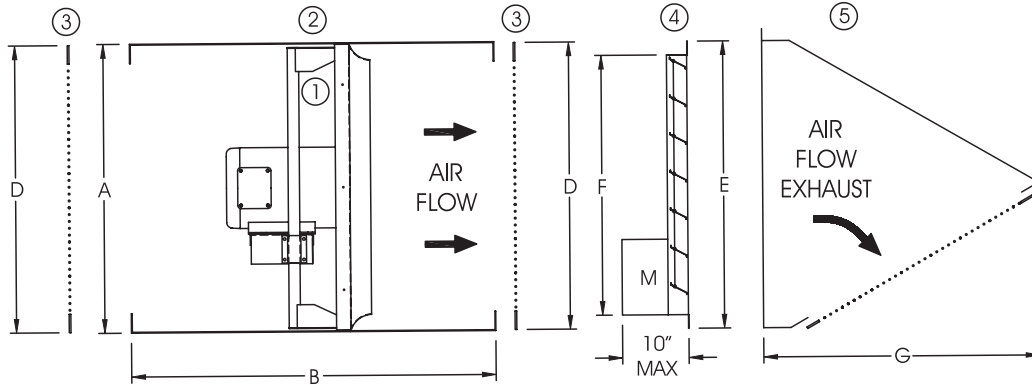
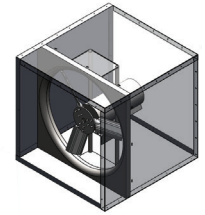

Fan Size	A (S.Q.) O.D. ①	Wall Housing ②				Minimum Wall Opening	Flat Guard ③	Damper ④		Rainhood Exhaust 45 Deg. ⑤		
		B Length						Square	D (SQ.)		E (O.D.)	F
		GED & DFE Only		DDE/DDS								
		Exhaust	Supply	Exhaust	Supply							
10/12	17	26	26	N/A	N/A	17 1/2	16	14 1/2	12	16 3/4		
14/16	21	26	26	N/A	N/A	21 1/2	20	18 1/2	16	20 1/4		
18/20	25	26	26	N/A	N/A	25 1/2	24	22 1/2	20	24 1/4		
24	31	44	44	44	44	31 1/2	30	28 1/2	26	28 1/2		
30	37	44	44	44	44	37 1/2	36	34 1/2	32	34 1/2		
36	43	N/A	N/A	44	44	43 1/2	42	40 1/2	38	40 1/2		
42	49	N/A	N/A	44	44	49 1/2	48	46 1/2	44	44 1/2		
48	55	N/A	N/A	44	44	55 1/2	54	52 1/2	50	49 1/2		
54	61	N/A	N/A	44	44	61 1/2	60	58 1/2	56	55		
60	67	N/A	N/A	44	44	67 1/2	66	64 1/2	62	69		

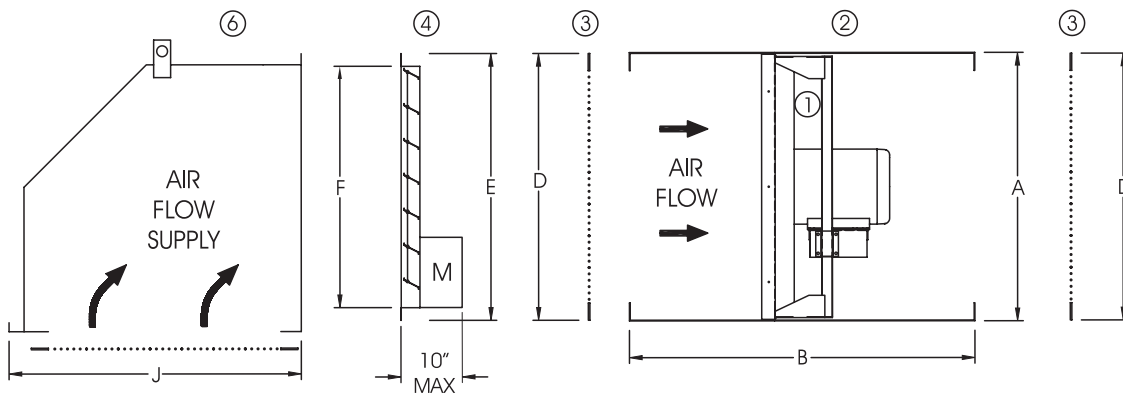

90 Deg. Supply Rainhood - Sizes 20 Thru 60

Fan Size	Width	Height	J	Gauge	Degree
20	22	22	27 3/4	18	90
24	27 1/4	26 1/2	38 1/2	18	90
30	32 1/2	33 1/2	44 1/2	18	90
36	38 1/2	39 1/4	49	18	90
42	44 1/2	45 1/4	56 1/2	18	90
48	50 1/2	51 1/2	62 1/2	18	90
54	56 3/4	57	73	18	90
60	62 3/4	63	73	18	90



WALL HOUSING STANDARD MOUNTING ARRANGEMENTS

The most common mounting arrangement (below left) leaves a clean building exterior and allows access to the fan, motor and drives from inside the building. Additional bracing angle, rod or cable (field provided) should be used in addition to the mounting angles to support the fan and wall housing assembly.

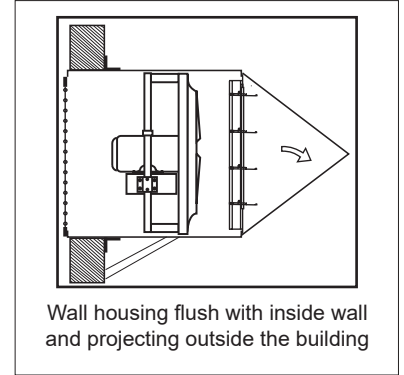
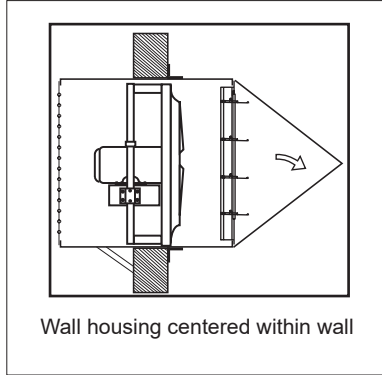
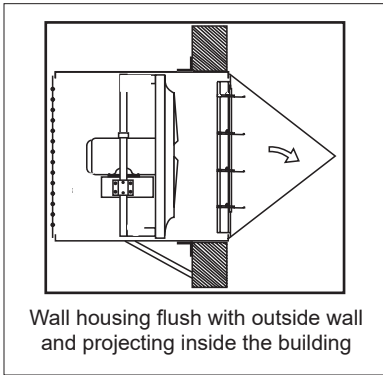

NOTE: Supply applications have the fan venturi spun on the opposite side of the fans shown above. The fans shown are exhaust. Rainhoods are required on supply applications and recommended on exhaust applications where additional weather protection is desired. Exhaust and/or supply fans installed as shown should be serviced from the interior of the building. Where service is required from the exterior of the building, consult the factory or representative for recommendations. All bracing shown is field provided. Field flashing and caulking of wall housing seams and unused mounting holes, will ensure a weather resistant installation.

PRESSURE LOSS GUIDE FOR ACCESSORIES

Use the estimated pressure drop graphs to help select the proper exhaust or supply fan that will deliver the desired airflow. Enter the graph from the bottom at the specified CFM and move vertically upward to the fan curve for the desired size, then horizontally to the left and read the estimated static pressure drop resulting from these typical accessory packages. Add the accessory pressure loss to the system (or building) design static pressure loss to obtain the total static pressure loss to be used for the proper fan selection.

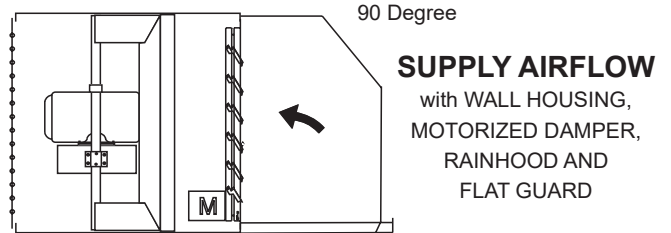
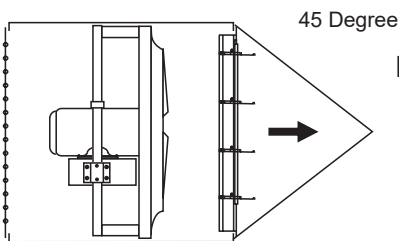

SIZES 10 THROUGH 24

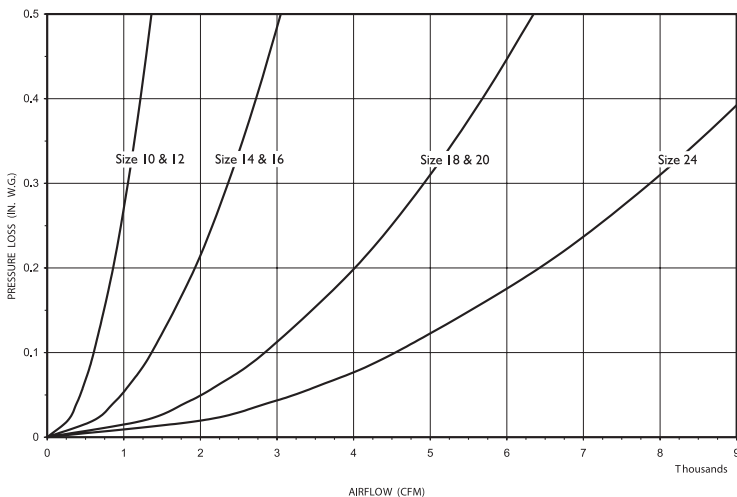

SIZES 30 THROUGH 60

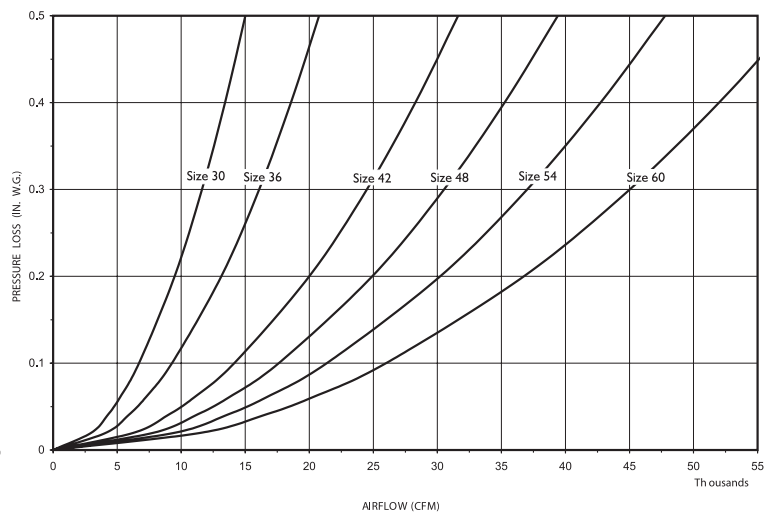

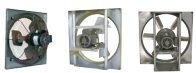

FILTERED WALL HOUSING MOUNTING OPTIONS

Filtered wall housings are available in both supply and exhaust configurations. They are available in nine (9) sizes for fans ranging from size 14 to 60 inches. They are designed with the draw-thru concept to achieve the highest filter and fan efficiencies.

Standard construction is galvanized steel. Mounting flanges are factory installed for either flush exterior or flush interior. Permanent 2-inch (51 mm) washable filters are accessed through a bolted or hinged panel and can be easily removed for cleaning.

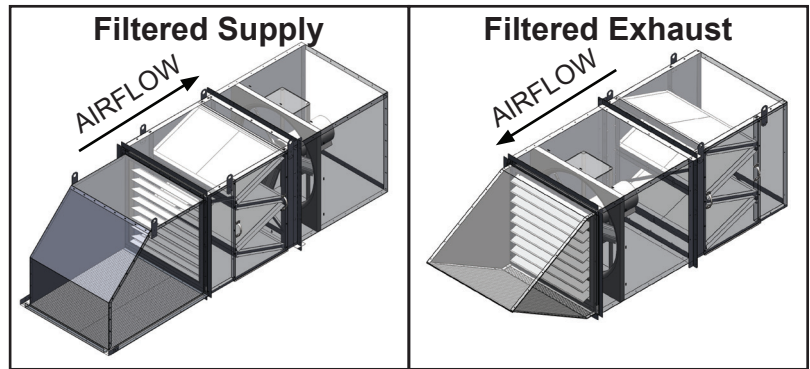

FILTERED SUPPLY WALL HOUSING

Standard Features and Options

1. **Wall Housing Box (Standard)**

2. **Filter Box (Standard)**

- Bolted or Hinged Door
- Includes 2 sets of flanges for mounting filter box to wall housing.

3. **Wall Mount Flanges**

- Set of 4 - shipped loose

4. **Damper (Optional)**

- Supply Type
- Gravity, Motorized, or Center Pivot

5. **Rain Hood (Optional)**

- 90 Degree - Supply Type

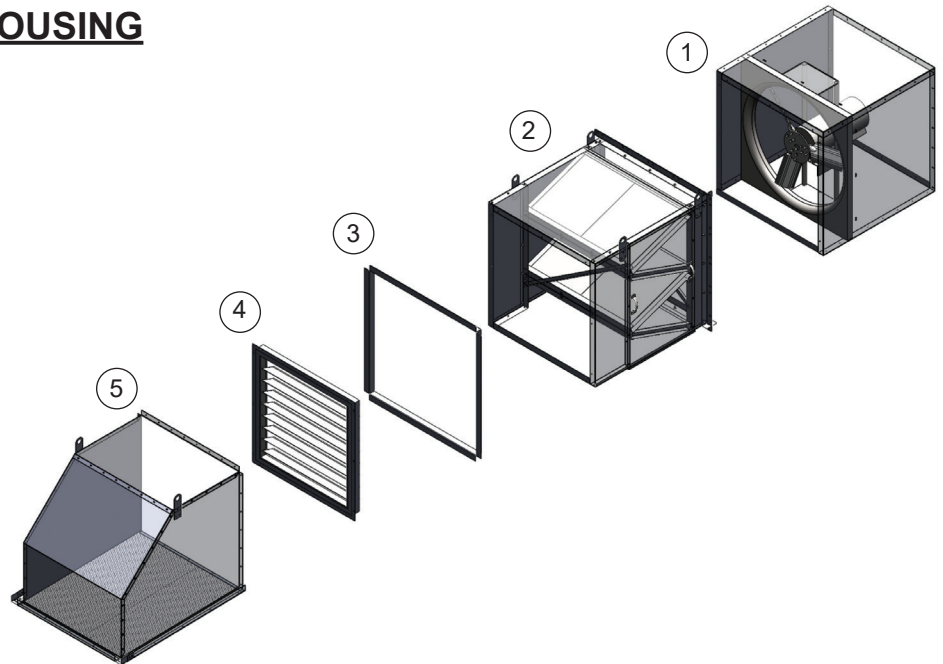

FILTERED EXHAUST WALL HOUSING

Standard Features and Options

1. **Wall Housing Box (Standard)**

2. **Filter Box (Standard)**

- Bolted or Hinged Door
- Includes 2 sets of flanges for mounting filter box to wall housing.

3. **Wall Mount Flanges**

- Set of 4 - shipped loose

4. **Damper (Optional)**

- Exhaust Type
- Gravity, Motorized, or Center Pivot

5. **Rain Hood (Optional)**

- 45 Degree - Exhaust Type

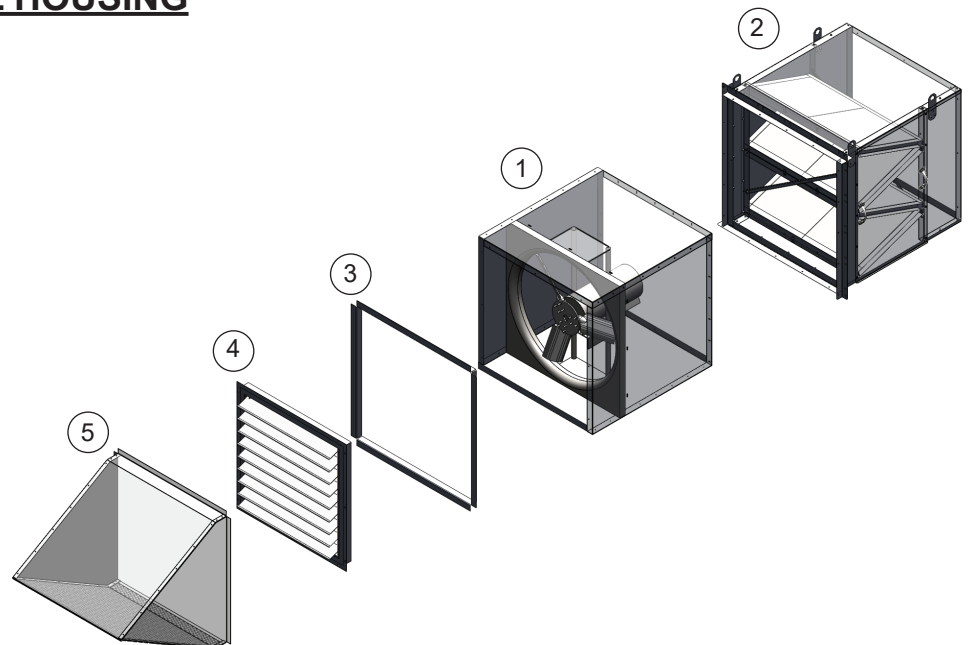



FILTERED WALL HOUSING MOUNTING OPTIONS Cont.

Filtered Wall Housing Dimensions

Filtered Supply

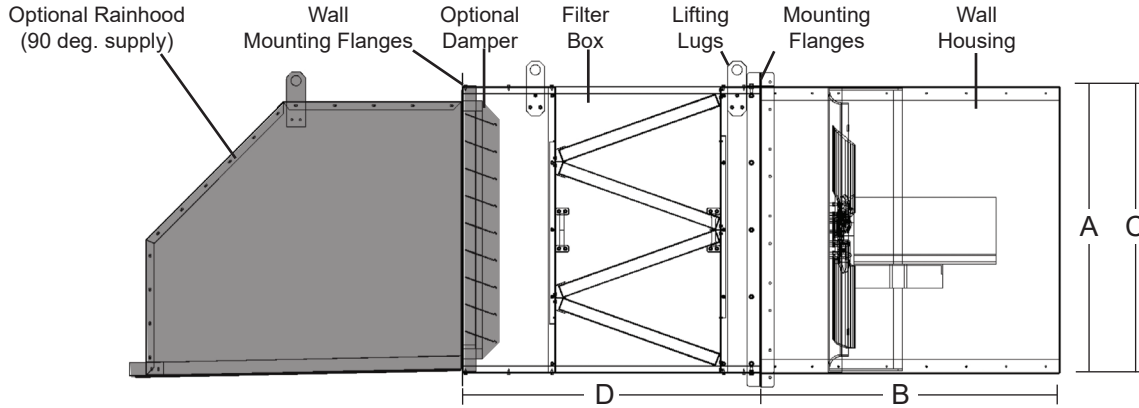

Fan Size	A (S.Q.) O.D.	Wall Housing B Length				Minimum Wall Opening Square	Filter Box			
		GED & DFE Only		DDE/DDS			C	D	# of Filters	Filter Actual Dimensions
		Exhaust	Supply	Exhaust	Supply					
14/16	21	26	26	N/A	N/A	21 1/2	21	39	2	19 5/8 x 19 5/8 x 1 7/8
18/20	25	26	26	N/A	N/A	25 1/2	25	44 1/8	3	19 5/8 x 24 5/8 x 1 7/8
24	31	44	44	44	44	31 1/2	31	41 1/8	4	19 5/8 x 24 5/8 x 1 7/8
30	37	44	44	44	44	37 1/2	37	44 1/8	8	15 5/8 x 24 5/8 x 1 7/8
36	43	N/A	N/A	44	44	43 1/2	43	44 1/8	8	19 5/8 x 24 5/8 x 1 7/8
42	49	N/A	N/A	44	44	49 1/2	49	44 1/8	10	19 5/8 x 24 5/8 x 1 7/8
48	55	N/A	N/A	44	44	55 1/2	55	40 1/2	12	19 5/8 x 24 5/8 x 1 7/8
54	61	N/A	N/A	44	44	61 1/2	61	44 1/8	15	19 5/8 x 24 5/8 x 1 7/8
60	67	N/A	N/A	44	44	67 1/2	67	44 1/8	15	19 5/8 x 24 5/8 x 1 7/8

Filtered Exhaust

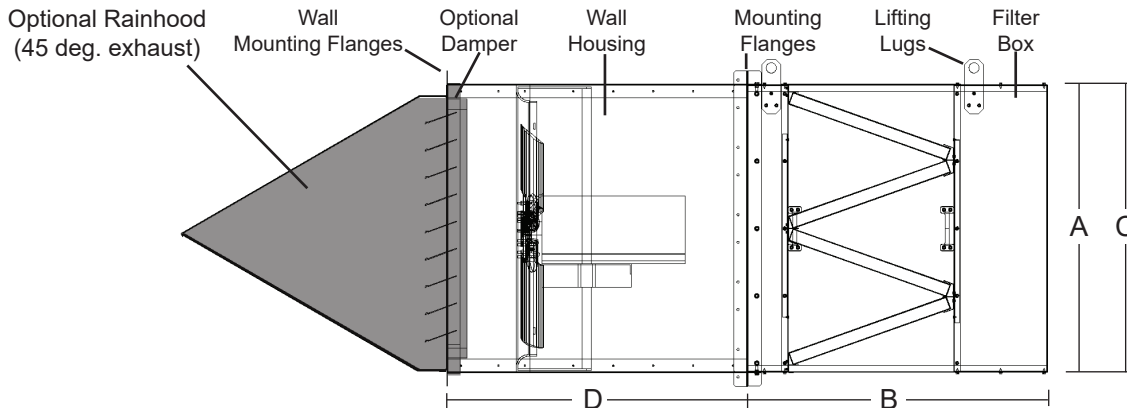

PRESSURE LOSS GUIDE FOR FILTER BOX

Use the estimated pressure drop graphs to help select the proper exhaust or supply fan that will deliver the desired airflow. Enter the graph from the bottom at the specified CFM and move vertically upward to the fan curve for the desired size, then horizontally to the left and read the estimated static pressure drop resulting from these typical accessory packages. Add the accessory pressure loss to the system (or building) design static pressure loss to obtain the total static pressure loss to be used for the proper fan selection.

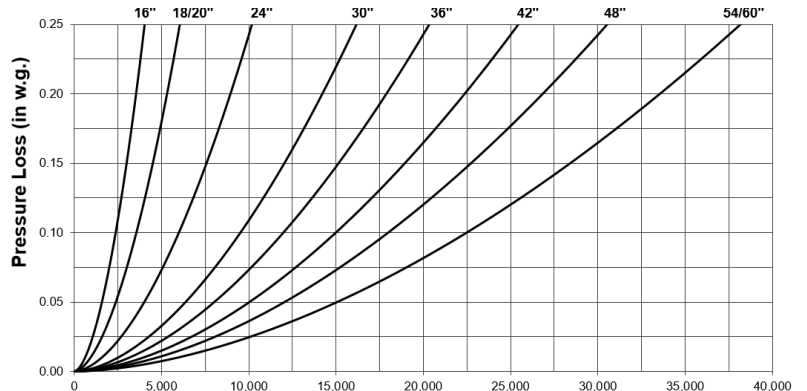



WALL COLLAR MOUNTING OPTIONS

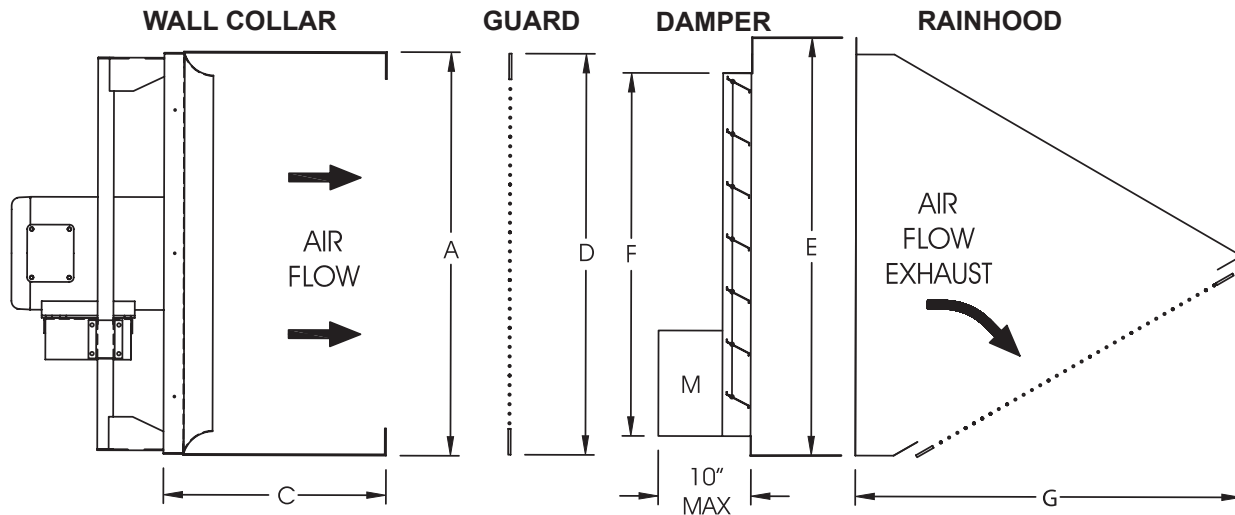

WALL COLLAR: This heavy-gauge, all G-90 galvanized (aluminum optional) mounting collar provides a simple solution to installing a fan in a rough wall opening when a rear safety guard is **NOT** required. A front wire guard or shutter and rainhood can be attached to the front flanges. The wall collar can be used in exhaust or supply applications for all fan sizes and maintain the proper clearance between the fan and damper. The wall collar is mounted with the fan on the interior side of the building. All collars ship fully assembled with the fan to lessen job site installation costs. We strongly recommend a rainhood and motorized shutter for all supply applications and for additional weather protection.



Fan Size	WALL COLLAR		MINIMUM WALL OPENING	FLAT GUARD	DAMPER		RAINHOOD Exhaust 45 Deg.
	A	C	Square	D (SQ.)	E (O.D.)	F	G
10/12	17	16	17 1/2	16	14 1/2	12	16 3/4
14/16	21	16	21 1/2	20	18 1/2	16	20 1/4
18/20	25	16	25 1/2	24	22 1/2	20	24 1/4
24	31	21	31 1/2	30	28 1/2	26	28 1/2
30	37	21	37 1/2	36	34 1/2	32	34 1/2
36	43	21	43 1/2	42	40 1/2	38	40 1/2
42	49	21	49 1/2	48	46 1/2	44	44 1/2
48	55	21	55 1/2	54	52 1/2	50	49 1/2
54	61	21	61 1/2	60	58 1/2	56	55
60	67	21	67 1/2	66	64 1/2	62	69

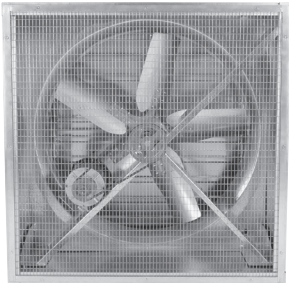

ACCESSORIES & OPTIONS **FOR MOUNTING ARRANGEMENTS**

Accessory or Option	
	<p>Safety Guards Safety Guards (Standard or Heavy-Duty Flat Guards) are strongly recommended to protect personnel from accidental injury and to prevent debris from entering the fan. OSHA approved guards are required in many installations including when the fans are within 7 feet of the floor or work/access area.</p>
	<p>Rainhoods or Weatherhoods Designed to provide additional weather protection by partially shielding the wall opening and should be used for all supply applications and whenever additional weather resistance is desired. The galvanized (aluminum optional) hood attaches to the wall housing or wall collar flanges. Field flashing and caulking will reduce moisture penetration. Shown with optional birdscreen.</p>
	<p>Dampers Used alone or in conjunction with the wall housing or wall collar, a complete line of dampers are available for exhaust or supply configurations.</p>



ACCESSORIES & OPTIONS FOR MOUNTING ARRANGEMENTS Cont.

Safety Guards

Safety guards are strongly recommended to protect personnel from accidental injury and to prevent debris from entering the fan. OSHA approved guards are required in many installations including when the fans are within 7 feet of the floor or work/access area.

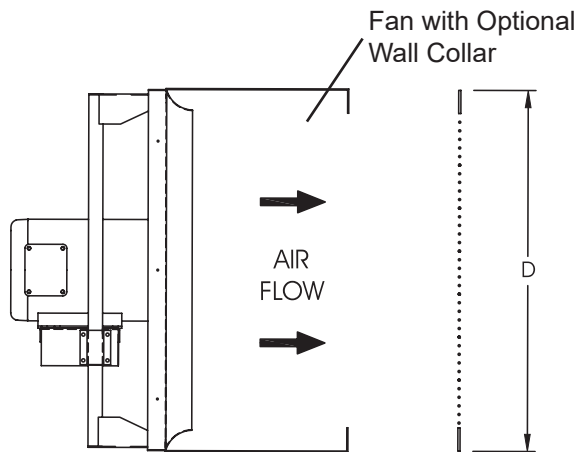

Dimensions

Fan Size	D (SQ.)
10/12	16
14/16	20
18/20	24
24	30
30	36
36	42
42	48
48	54
54	60
60	66

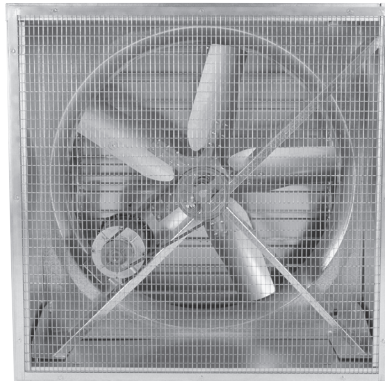

Standard Duty Flat Wire Guard

The removable safety guard satisfies OSHA requirements when used with the optional wall housing as a motor-side (rear) guard. The 16 ga. 1/2" X 1" welded wire mesh is mounted in a galvanized frame and attaches to the inward flanges of the wall housing.

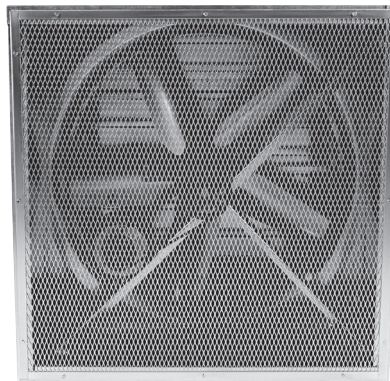

Heavy-Duty Flat Wire Guard

The removable safety guard satisfies OSHA requirements when used with the optional wall housing as a motor-side (rear) guard. The H.D. expanded aluminum mesh is mounted in a galvanized frame and attaches to the inward flanges of the wall housing.



ACCESSORIES & OPTIONS FOR MOUNTING ARRANGEMENTS Cont.

Rainhoods or Weatherhoods

Designed to provide additional weather protection by partially shielding the wall opening and should be used for all supply applications and whenever additional weather resistance is desired. The galvanized (aluminum optional) hood attaches to the wall housing or wall collar flanges. Field flashing and caulking will reduce moisture penetration. Shown with optional birdscreen.

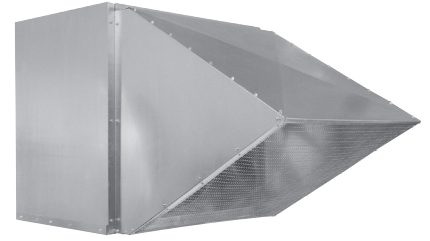

45 Degree Exhaust or Supply Sizes 10-16

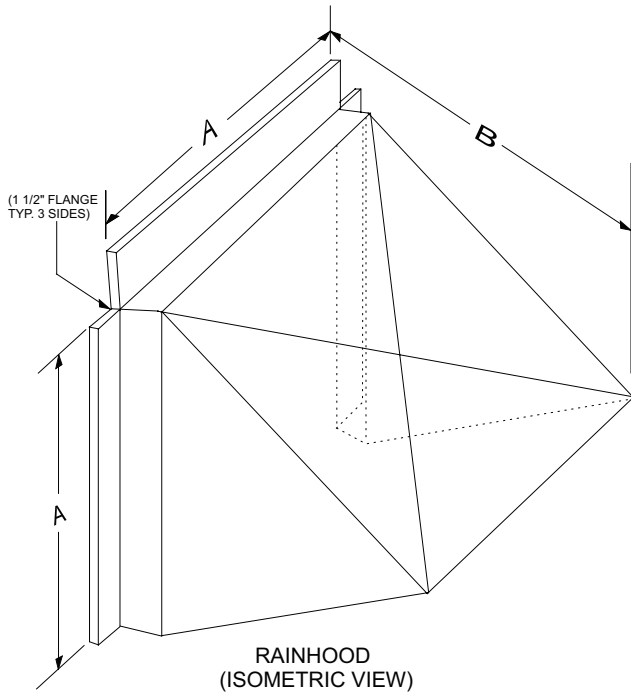

RAINHOOD
(ISOMETRIC VIEW)

Fan Size	A	B	GAUGE (2)	AVG. WT.
10/12	14	16-1/4	18	15
14/16	18	20-1/4	18	20
18/20	22	24-1/2	18	25
24	28	28-1/2	18	30
30	34	34-1/2	18	40
36	40	40-1/2	18	50
42	46	46-1/2	18	60
48	52	49-1/2	16	70
54	58	58-1/2	16	120
60	64	64-1/2	16	175

90 Degree Supply Sizes 18-60

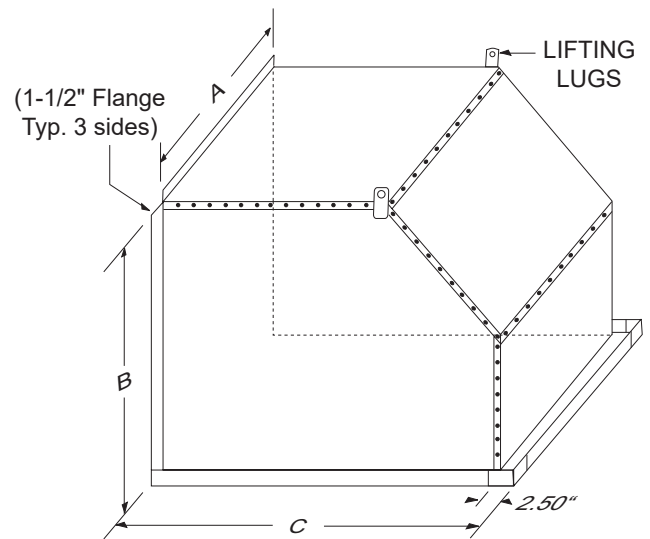

Fan Size	A	B	C	GAUGE (2)	AVG. WT.
20	22	22	27-3/4	18	25
24	27-1/4	26-1/2	38-1/2	18	30
30	32-1/2	33-1/2	44-1/2	18	40
36	38-1/2	39-1/4	49	18	50
42	44-1/2	45-1/4	56-1/2	18	60
48	50-1/2	51-1/2	62-1/2	18	70
54	56-3/4	57	73	18	120
60	62-3/4	63	73	18	175



ACCESSORIES & OPTIONS FOR MOUNTING ARRANGEMENTS Cont.

Damper Types (Shutters)

Heavy-Duty Galvanized Exhaust Motorized Shutter



This damper has a flanged frame and is designed to fit the inside flanges of the optional wall housing or wall mounting collar. The frame and blades are constructed of galvanized steel and are rated to 3000 FPM with proper clearance as provided by all factory accessories. The damper body recesses into the opening for a flush appearance.

Standard Duty Aluminum Exhaust Gravity Shutter



This damper can greatly reduce the infiltration of outside air and although not completely watertight, will provide weather protection in an economical fashion. Constructed with a galvanized frame and aluminum blades this damper is rated to 2000 FPM with the proper clearance as provided by all factory accessories. The damper body is recessed into the opening for a flush appearance.

Heavy-Duty Galvanized Supply Motorized Shutter



The motorized option improves weather protection by providing a tighter closure seal and is recommended for all supply applications. Heavy-duty dampers are constructed with galvanized frames and blades and are rated to 3000 FPM. The damper body is not recessed providing extra clearance between the fan and damper blades.

Standard Duty Aluminum Supply Motorized Shutter



The motorized option improves weather protection by providing a tighter closure seal and is recommended for all supply applications. Standard duty dampers are constructed with galvanized frames and aluminum blades and are rated to 2000 FPM. The damper body is not recessed providing extra clearance between the fan and damper blades.

Center Pivot Motorized Damper - Supply or Exhaust



The flanged frame damper is designed to recess inside the flanges of the optional wall housing or wall mounting collar. The center pivot style damper provides superior weather resistance. Galvanized (optional aluminum) construction is rated to 3500 FPM with proper clearance as provided by all factory accessories.

Electric Damper Operators

Electric damper operators provide more positive open and closed damper positions which helps increase weather resistance. Power open - spring close (POSC) motor and linkage kits are field installed (except for center pivot style) and are available in 24, 120/240, or 460 volts (single phase) and require approximately 0.5 amps at 120/1/60 power supply. Transformers are available for voltage reduction. For fan motors 5HP and larger, we recommend a factory tilt switch or "delay-on" timer in the control circuit (by others) to allow the damper to open prior to allowing fan operation, which will protect the damper blades and fan from damage when the fan is first energized.

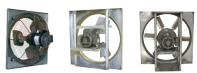

ACCESSORIES & OPTIONS

FOR MOUNTING ARRANGEMENTS Cont.

Dimensions (Standard and Heavy-Duty Dampers)

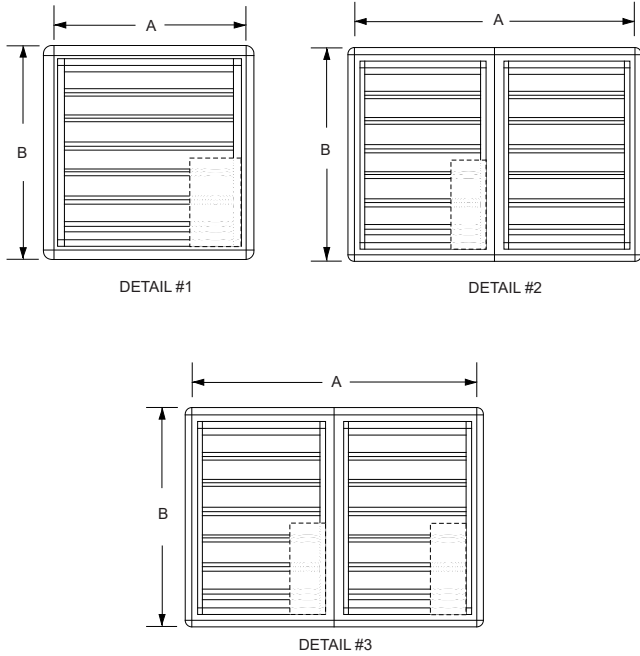
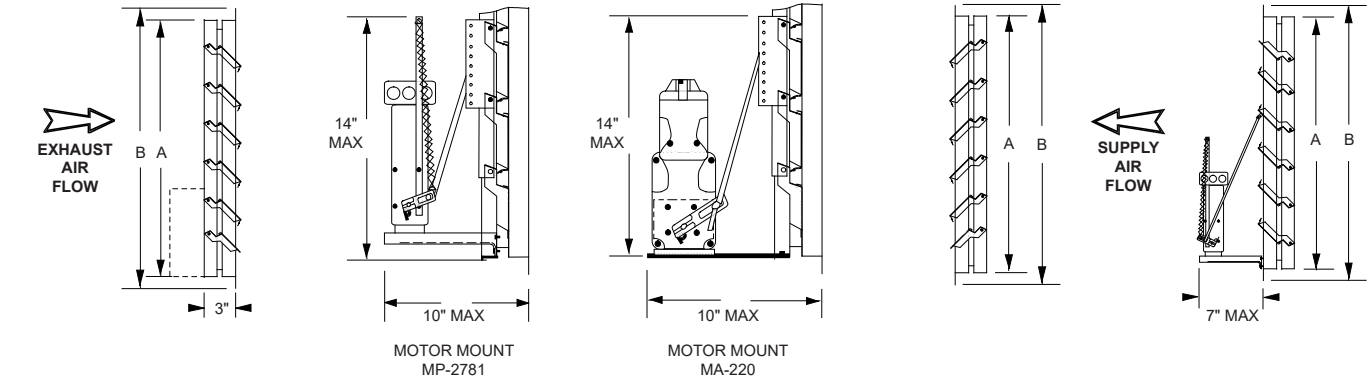

Fan Size	A Sq. Size	B Sq. OD Flange	Panels (Detail)	Motor Type			
				Exhaust		Supply	
				Type	Qty	Type	Qty
10/12	12	14 1/2	1	MP-2781	1	MP-2781-S	1
14/16	16	18 1/2	1	MP-2781	1	MP-2781-S	1
18/20	20	22 1/2	1	MP-2781	1	MP-2781-S	1
24	26	28 1/2	1	MP-2781	1	MP-2781-S	1
30	32	34 1/2	1	MP-2781	1	MA-220-S	1
36	38	40 1/2	1	MA-220	1	MA-220-S	1
42	44	46 1/2	2	MA-220	1	MA-220-S	2
48	50	52 1/2	2	MA-220	1	MA-220-S	2
54	56	58 1/2	3	MA-220	2	MA-220-S	2
60	62	64 1/2	3	MA-220	2	MA-220-S	2

Heavy Duty Dampers required on all units with 7 1/2HP motors and above.

Dimensions (Center Pivot Motorized Damper)

Fan Size	Opening Required	A O.D.	B (1)	C "Size"	D (Center of Holes)	# of Panels	G	
							Closed (E-1)	Open (E-2)
24	27	29	24-1/2	26	-	1 x 1	7-1/4	8-1/2
30	33	35	30-1/2	32	-	1 x 1	10-1/4	13-3/4
36	39	41	36-1/2	38	19-1/2	1 x 1	10-1/4	13-3/4
42	45	47	42-1/2	44	22-1/2	1 x 1	10-1/4	13-3/4
48	51	53	48-1/2	50	25-1/2	2 x 1	10-1/4	13-3/4
54	57	59	54-1/2	56	28-1/2	2 x 1	10-1/4	12-3/4
60	63	65	60-1/2	62	31-1/2	2 x 1	10-1/4	12-3/4

Fan Size	Motor (2)		
	Power Supply	Max Amps	Stall Torque (in. lbs)
24-48	120-240V 60Hz	0.3/0.6	25
54-72	240V 60Hz	0.5	60

(1) Minimum opening to clear pins.
 (2) Motor is 60 Hz, single phase continuous duty with 104°F (40°C), maximum ambient temperature

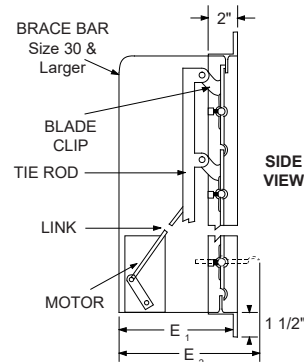
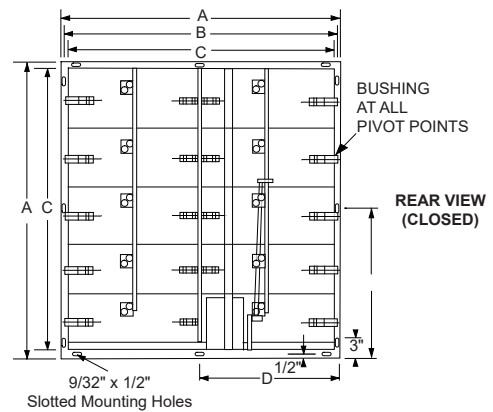



ACCESSORIES & OPTIONS

Electrical Accessories are available to simplify the installation and reduce the total project cost.

Disconnect Switches can be shipped loose or factory mounted and wired (except explosion proof and two speed) in NEMA 1, 3R, 4X, or other enclosures. Two-speed and explosion proof disconnects are available but may be subject to more stringent code requirements. It is the responsibility of the buyer and the installer to comply with all local and national codes.

Aluminum Construction is available for most models and typically includes propeller blades, fan panel, motor and drive support (large frame motors may have steel reinforcement) and accessories. When an explosion proof motor is specified, aluminum fan construction must be used for additional spark resistance.

Extended Lube Lines provide convenient access for routine bearing lubrication. Lubrication lines are installed from the fan shaft bearings to the exterior of the wall housing or sheet metal motorside guard and are provided with zerk fittings.

Paints and Coatings for protective and decorative purposes. Available coatings include: Epoxy, Synthetic Resin, and Heresite (air-dried phenolic). Contact your JencoFan representative or the factory for more information on available coatings and colors.

Mounting Angles facilitate the installation and a secure attachment of the wall housing or wall collar into the framed wall opening. Galvanized or aluminum angles are available and are pre-cut to the proper length. Additional bracing, mounting hardware, flashing and caulking are typically provided by the installer.

Factory Wiring can simplify jobsite installation and reduce the overall project cost. Optional services include wiring of motor, disconnect switch, damper actuator, and other custom controls. Please note that some wiring options may not be available for explosion proof, two speed and special motors.



MODELS GED/GSD & eGED/eGSD CONSTRUCTION FEATURES

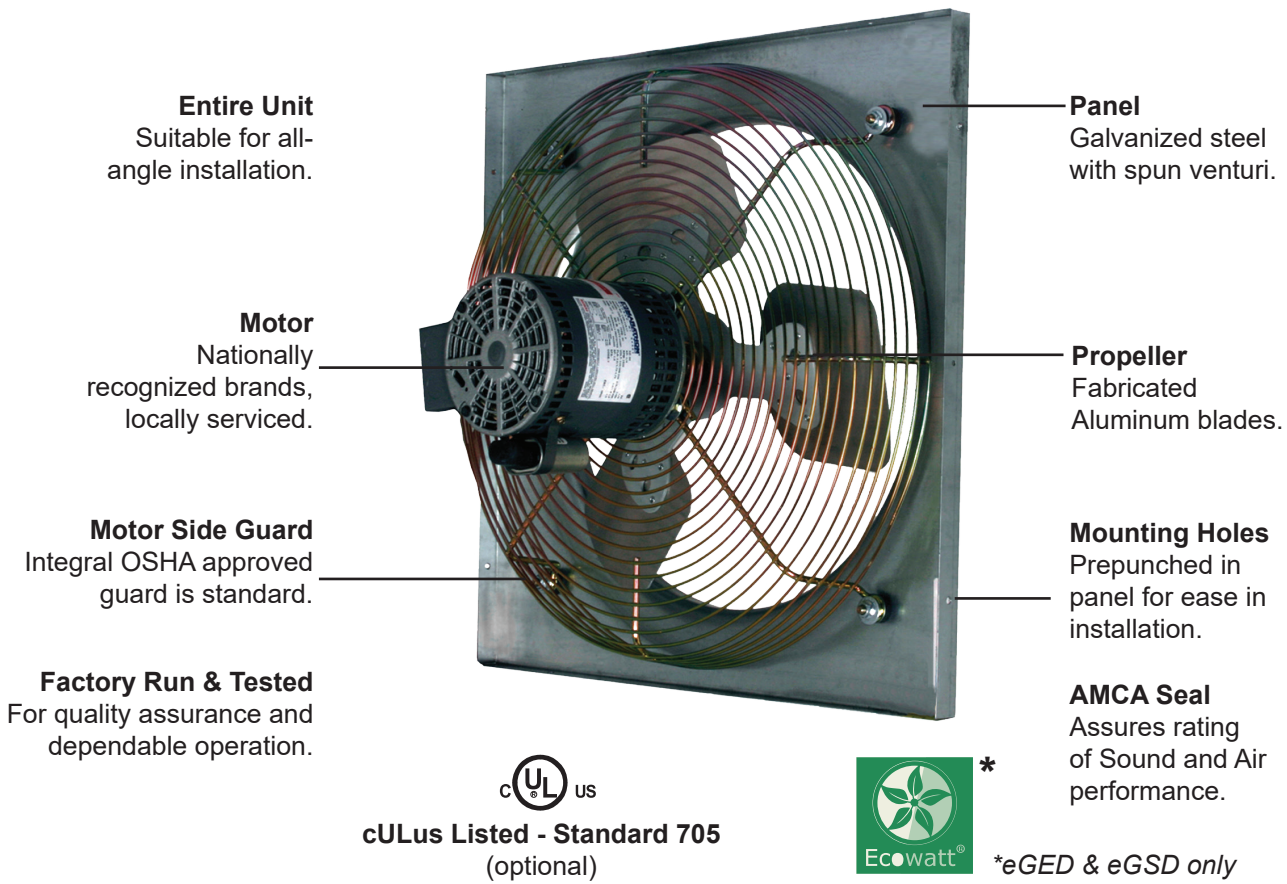

Industry best 5 year fan housing warranty, 1 year motor warranty

Construction/Specification Checklist

Panel Assembly

- Galvanized steel, 16 or 18 gauge, G-90.
- One piece spun venturi for maximum efficiency.
- Prepunched mounting holes for easy installation.
- Formed flanges for added rigidity.
- Integral OSHA approved motorside guard.

Propeller

- Fabricated aluminum blades, precision pitch.
- Mounted directly on motor shaft for maximum efficiency.
- Separate exhaust and supply designs.
- Statically and dynamically balanced.

Certifications

- AMCA Air and Sound Licensed.
- cULus 705 Listed Power Roof Ventilator label assures electrical reliability.
- UL label must be specified when needed.

Motors

- Nationally recognized brands, locally serviced.
- Sealed ball bearings on larger fractional PSCs.
- Sleeve bearings on smaller fractional PSCs.

Electronically Commutated Motors (eGED/eGSD)

- Brands are nationally recognized and locally serviced.
- Easy speed variability by ECM Speed Control.
- Motor has 80% usable turndown vs. 30% on a PSC motor.
- Internal motor circuitry converts single phase AC power to DC voltage for increased efficiencies.
- All motors are rated for continuous duty.
- 3/4 HP Motor is 230V. 1/3 HP & 1/2 HP Motors are 115V.

Entire Fan Unit

- Suitable for all-angle installation.
- Completely assembled and factory tested prior to shipment.

All specifications are subject to change without notice unless approved in submittal by JencoFan.



eMotor - Electronically Commutated Motor

JencoFan's eMotor is 115V, 60 Hz in 1/3 HP & 1/2 HP and is 230V in 3/4 HP. This fully controllable motor offers both reliability and low maintenance in one of the most efficient motor fan combinations in the industry.

When used in JencoFan's eGED/eGSD, the eMotor is the ideal solution for a low cost, fully controlled ventilation system. This motor in the eGED/eGSD can move air volumes up to 3,700 CFM.



Features and Advantages

- Easy speed variability by ECM Speed Control.
- Motor has 80% usable turndown vs. 30% on a PSC motor.
- Internal motor circuitry converts 115V single phase AC power to DC voltage for increased efficiencies.
- cULus 705 Listing.

Energy Savings = \$ Savings

eGED with 1/2 HP Motor - Continuous Ventilation

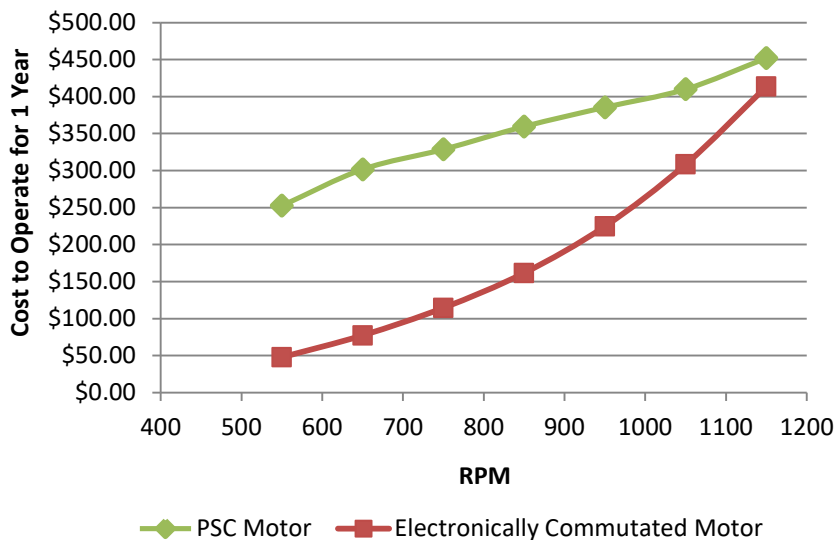

Cost to Operate Motors @ 650 RPM Continuous Ventilation

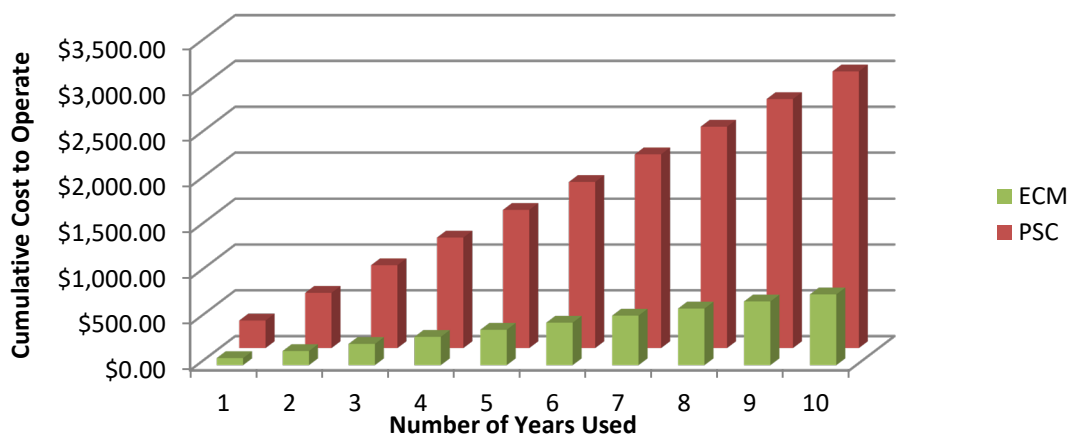



PERFORMANCE/DIMENSIONS

Model GED (Exhaust)/GSD (Supply) & eGED/eGSD

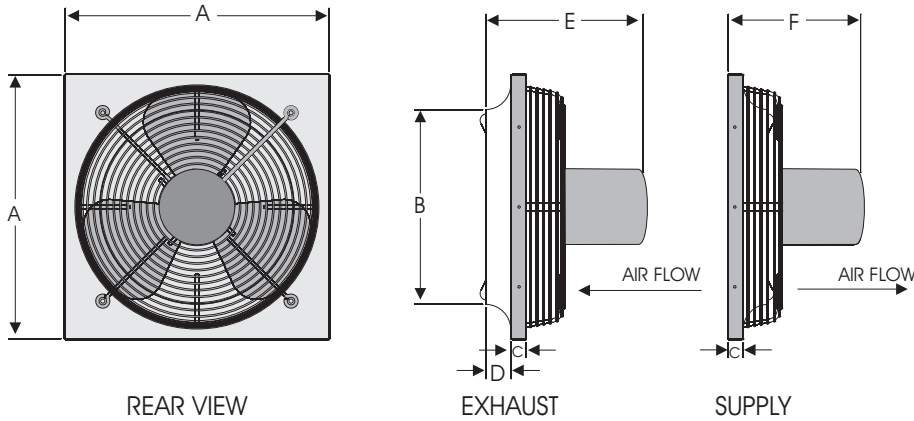

GED/GSD, eGSD/eGSD Size	Dimensions (in.)						Avg. Ship Wt. (lbs.)
	A	B	C	D	E*	F*	
10	16	10-1/2	1	2	11	9	30
12	16	12-1/2	1	2	14	12	30
14	20	14-1/2	1	2	14	12	34
16	20	16-1/2	1	2	14	12	37
18	24	18-1/2	1	2	15	13	45
20	24	20-1/2	1	2	15	13	50

A. Outside dimension of square panel.
 B. Diameter of venturi.
 C. Width of flange, 1" for all models.
 D. Depth of venturi, 2" for all models.
 E. Depth of fan (exhaust).
 F. Depth of fan (supply).
 * **Varies with motor selection.**

SIZE 10

Motor HP	RPM	Sones @ 0" SP		Static Pressure in Inches w.g.							
				0	.10	.125	.25	.375	.50	.625	.75
GED1/10 HP 1550 RPM	1150	2.9	CFM	580	343	327	-	-	-	-	-
			BHP	0.03	0.03	0.03	-	-	-	-	-
	1250	3.5	CFM	631	397	368	-	-	-	-	
			BHP	0.04	0.04	0.04	-	-	-	-	
	1350	4.0	CFM	681	460	416	227	-	-	-	
			BHP	0.06	0.06	0.06	0.05	-	-	-	
	1450	4.6	CFM	731	575	469	347	-	-	-	
			BHP	0.07	0.07	0.07	0.07	-	-	-	
	1550	5.3	CFM	782	646	558	428	-	-	-	
			BHP	0.08	0.08	0.08	0.08	-	-	-	

Speed (RPM) shown is nominal. Performance is based on actual speed of test.
 Performance certified is for installation type A-free inlet, free outlet. Performance ratings do not include the effects of appurtenances (accessories).
 The sound ratings shown are loudness values in fan sones @ 5' (1.5m) in a hemispherical free field calculated per AMCA Standard 301. Installation Type A: free inlet hemispherical sone levels.

Motors designed for use with optional speed controller.
 cULus available on most models (optional).
 Supply performance is obtained by reversing the direction of the venturi.



JencoFan, Div. of Soler & Palau Ventilation Group, certifies that the models GED & GSD are licensed to bear the AMCA Seal. The ratings shown are based on test and procedures performed in accordance with AMCA Publication 211 and AMCA Publication 311 and comply with the requirement of the AMCA Certified Ratings Program.





SIZE 12

Motor HP	RPM	Sones @ 0" SP		Static Pressure in Inches w.g.								
				0	.10	.125	.25	.375	.50	.625	.75	
GED/GSD 1/10 HP 1550 RPM	1150	5.3	CFM	1131	953	-	-	-	-	-	-	-
			BHP	0.05	0.05	-	-	-	-	-	-	-
	1250	6.2	CFM	1230	1080	1017	-	-	-	-	-	-
			BHP	0.06	0.06	0.08	-	-	-	-	-	-
	1350	7.1	CFM	1328	1197	1149	-	-	-	-	-	-
			BHP	0.08	0.08	0.08	-	-	-	-	-	-
	1450	8.1	CFM	1426	1307	1270	830	-	-	-	-	-
			BHP	0.10	0.10	0.10	0.10	-	-	-	-	-
	1550	9.3	CFM	1525	1414	1383	1049	-	-	-	-	-
			BHP	0.12	0.12	0.12	0.12	-	-	-	-	-
GED/GSD 1/4 HP 1625 RPM	1125	4.6	CFM	1038	891	765	-	-	-	-	-	-
			BHP	0.14	0.15	0.17	-	-	-	-	-	-
	1225	5.3	CFM	1130	1001	952	-	-	-	-	-	-
			BHP	0.06	0.06	0.07	-	-	-	-	-	-
	1325	6.2	CFM	1222	1096	1074	600	-	-	-	-	-
			BHP	0.07	0.08	0.08	0.09	-	-	-	-	-
	1425	7.1	CFM	1315	1200	1172	728	-	-	-	-	-
			BHP	0.09	0.10	0.10	0.11	-	-	-	-	-
	1525	8.0	CFM	1407	1303	1271	901	544	-	-	-	-
			BHP	0.11	0.12	0.12	0.12	0.15	-	-	-	-
1625	9.0	CFM	1499	1404	1375	1159	739	-	-	-	-	
		BHP	0.14	0.14	0.14	0.16	0.17	-	-	-	-	
eGED/eGSD 1/3 HP 1750 RPM	825	2.3	CFM	761	-	-	-	-	-	-	-	-
			BHP	0.02	-	-	-	-	-	-	-	-
	925	3.1	CFM	853	489	-	-	-	-	-	-	-
			BHP	0.02	0.03	-	-	-	-	-	-	-
	1025	3.8	CFM	946	727	535	-	-	-	-	-	-
			BHP	0.03	0.04	0.04	-	-	-	-	-	-
	1125	4.6	CFM	1038	891	765	-	-	-	-	-	-
			BHP	0.14	0.15	0.17	-	-	-	-	-	-
	1225	5.3	CFM	1130	1001	952	-	-	-	-	-	-
			BHP	0.06	0.06	0.07	-	-	-	-	-	-
	1325	6.2	CFM	1222	1096	1074	600	-	-	-	-	-
			BHP	0.07	0.08	0.08	0.09	-	-	-	-	-
	1425	7.1	CFM	1315	1200	1172	728	-	-	-	-	-
			BHP	0.09	0.10	0.10	0.11	-	-	-	-	-
	1525	8.0	CFM	1407	1303	1271	901	544	-	-	-	-
			BHP	0.11	0.12	0.12	0.12	0.15	-	-	-	-
	1625	9.0	CFM	1499	1404	1375	1159	739	-	-	-	-
			BHP	0.14	0.14	0.14	0.16	0.17	-	-	-	-
	1675	9.6	CFM	1545	1453	1426	1255	825	-	-	-	-
			BHP	0.15	0.16	0.16	0.17	0.18	-	-	-	-
1725	10.1	CFM	1591	1503	1477	1336	874	-	-	-	-	
		BHP	0.18	0.17	0.17	0.19	0.19	-	-	-	-	
1750	10.4	CFM	1614	1528	1502	1371	897	607	-	-	-	
		BHP	0.17	0.18	0.18	0.19	0.20	0.23	-	-	-	



JencoFan, Div. of Soler & Palau Ventilation Group, certifies that the models GED & GSD are licensed to bear the AMCA Seal. The ratings shown are based on test and procedures performed in accordance with AMCA Publication 211 and AMCA Publication 311 and comply with the requirement of the AMCA Certified Ratings Program.



Speed (RPM) shown is nominal. Performance is based on actual speed of test.

Performance certified is for installation type A-free inlet, free outlet. Performance ratings do not include the effects of appurtenances (accessories).

The sound ratings shown are loudness values in fan sones @ 5' (1.5m) in a hemispherical free field calculated per AMCA Standard 301. Installation Type A: free inlet hemispherical sone levels.

Motors designed for use with optional speed controller.

Supply performance is obtained by reversing the direction of the venturi.

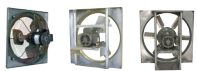

SIZE 14

Motor HP	RPM	Sones @ 0" SP		Static Pressure in Inches w.g.								
				0	.10	.125	.25	.375	.50	.625	.75	
GED/GSD 1/4 HP 1625 RPM	625	1.1	CFM	787	-	-	-	-	-	-	-	-
			BHP	0.01	-	-	-	-	-	-	-	-
	725	1.8	CFM	913	-	-	-	-	-	-	-	-
			BHP	0.02	-	-	-	-	-	-	-	-
	825	2.5	CFM	1039	604	513	-	-	-	-	-	-
			BHP	0.03	0.03	0.03	-	-	-	-	-	-
	925	3.2	CFM	1165	867	681	-	-	-	-	-	-
			BHP	0.04	0.04	0.04	-	-	-	-	-	-
	1025	3.9	CFM	1291	1057	951	-	-	-	-	-	-
			BHP	0.05	0.06	0.06	-	-	-	-	-	-
	eGED/eGSD 1/3 HP 1750 RPM	1125	4.6	CFM	1417	1229	1142	664	-	-	-	-
				BHP	0.07	0.08	0.08	0.07	-	-	-	-
1225		5.3	CFM	1543	1383	1320	820	581	-	-	-	
			BHP	0.09	0.10	0.10	0.09	0.10	-	-	-	
1325		6.1	CFM	1669	1527	1479	1001	739	-	-	-	
			BHP	0.12	0.12	0.12	0.12	0.12	-	-	-	
1425		6.9	CFM	1795	1665	1627	1291	883	693	-	-	
			BHP	0.15	0.15	0.15	0.15	0.15	0.15	-	-	
1525		7.7	CFM	1921	1800	1768	1486	1048	846	597	-	
			BHP	0.18	0.19	0.19	0.19	0.18	0.18	0.19	-	
1625		8.5	CFM	2047	1934	1905	1679	1231	989	828	-	
			BHP	0.22	0.22	0.22	0.23	0.22	0.22	0.22	-	
GED/GSD 1/2 HP 1625 RPM		1675	9.0	CFM	2110	2000	1972	1770	1371	1065	903	-
				BHP	0.24	0.25	0.25	0.26	0.25	0.24	0.24	-
		1725	9.4	CFM	2173	2066	2040	1855	1529	1147	974	803
				BHP	0.26	0.27	0.27	0.28	0.27	0.26	0.26	0.27
		1750	9.6	CFM	2205	2100	2073	1896	1592	1191	1009	857
				BHP	0.27	0.28	0.28	0.29	0.28	0.27	0.27	0.28
GED/GSD 1/2 HP 1625 RPM	1225	7.0	CFM	1920	1662	1604	-	-	-	-	-	
			BHP	0.19	0.19	0.19	-	-	-	-	-	
	1325	7.9	CFM	2076	1863	1766	1300	-	-	-	-	
			BHP	0.25	0.24	0.24	0.25	-	-	-	-	
	1425	8.9	CFM	2233	2043	1971	1432	1260	-	-	-	
			BHP	0.17	0.18	0.18	0.19	0.20	-	-	-	
	1525	10.0	CFM	2390	2215	2163	1787	1445	1035	-	-	
			BHP	0.37	0.37	0.37	0.37	0.38	0.37	-	-	
	1625	11.1	CFM	2546	2383	2340	2100	1594	1406	818	-	
			BHP	0.45	0.45	0.45	0.45	0.45	0.45	0.45	-	

Speed (RPM) shown is nominal. Performance is based on actual speed of test.
 Performance certified is for installation type A-free inlet, free outlet. Performance ratings do not include the effects of appurtenances (accessories).
 The sound ratings shown are loudness values in fan sones @ 5' (1.5m) in a hemispherical free field calculated per AMCA Standard 301. Installation Type A: free inlet hemispherical sone levels.

Motors designed for use with optional speed controller.

cULus available on most models (optional).

Supply performance is obtained by reversing the direction of the venturi.



JencoFan, Div. of Soler & Palau Ventilation Group, certifies that the models GED & GSD are licensed to bear the AMCA Seal. The ratings shown are based on test and procedures performed in accordance with AMCA Publication 211 and AMCA Publication 311 and comply with the requirement of the AMCA Certified Ratings Program.





SIZE 16

Motor HP	RPM	Sones @ 0" SP		Static Pressure in Inches w.g.								
				0	.10	.125	.25	.375	.50	.625	.75	
GED/GSD 1/4 HP 1075 RPM	775	4.6	CFM	1783	1204	-	-	-	-	-	-	-
			BHP	0.09	0.09	-	-	-	-	-	-	-
	875	5.9	CFM	2014	1660	1378	-	-	-	-	-	-
			BHP	0.13	0.13	0.13	-	-	-	-	-	-
	975	7.4	CFM	2244	1981	1842	-	-	-	-	-	-
			BHP	0.17	0.17	0.17	-	-	-	-	-	-
	1075	8.6	CFM	2474	2238	2174	-	-	-	-	-	-
			BHP	0.23	0.23	0.23	-	-	-	-	-	-
GED/GSD 1/3 HP 1625 RPM	625	1.7	CFM	1029	-	-	-	-	-	-	-	-
			BHP	0.02	-	-	-	-	-	-	-	-
	725	2.5	CFM	1194	584	-	-	-	-	-	-	-
			BHP	0.03	0.03	-	-	-	-	-	-	-
	825	3.4	CFM	1359	965	703	-	-	-	-	-	-
			BHP	0.04	0.04	0.04	-	-	-	-	-	-
	925	4.2	CFM	1523	1251	1089	-	-	-	-	-	-
			BHP	0.05	0.05	0.05	-	-	-	-	-	-
	1025	5.1	CFM	1688	1448	1378	-	-	-	-	-	-
			BHP	0.07	0.07	0.07	-	-	-	-	-	-
	1125	6.0	CFM	1853	1636	1578	-	-	-	-	-	-
			BHP	0.10	0.10	0.10	-	-	-	-	-	-
	1225	6.9	CFM	2018	1816	1768	1219	-	-	-	-	-
			BHP	0.13	0.13	0.13	0.13	-	-	-	-	-
	1325	7.9	CFM	2182	1994	1950	1600	-	-	-	-	-
			BHP	0.16	0.16	0.16	0.16	-	-	-	-	-
1425	9.0	CFM	2347	2170	2129	1893	1204	-	-	-	-	
		BHP	0.20	0.20	0.20	0.20	0.20	-	-	-	-	
1525	10.0	CFM	2512	2344	2306	2103	1590	1004	-	-	-	
		BHP	0.24	0.25	0.25	0.24	0.24	0.24	-	-	-	
1625	11.4	CFM	2676	2518	2482	2298	1968	1318	889	-	-	
		BHP	0.30	0.30	0.30	0.30	0.30	0.30	0.30	-	-	
1675	12.0	CFM	2759	2604	2569	2394	2134	1497	1038	632	-	
		BHP	0.32	0.33	0.33	0.32	0.33	0.32	0.32	0.32	0.33	
1725	12.7	CFM	2841	2690	2656	2487	2269	1694	1181	795	-	
		BHP	0.35	0.36	0.36	0.35	0.36	0.35	0.35	0.35	0.36	
1750	13.1	CFM	2882	2733	2699	2533	2330	1793	1257	877	-	
		BHP	0.37	0.37	0.37	0.37	0.37	0.37	0.37	0.37	0.37	

Speed (RPM) shown is nominal. Performance is based on actual speed of test.
 Performance certified is for installation type A-free inlet, free outlet. Performance ratings do not include the effects of appurtenances (accessories).
 The sound ratings shown are loudness values in fan sones @ 5' (1.5m) in a hemispherical free field calculated per AMCA Standard 301. Installation Type A: free inlet hemispherical sone levels.

Motors designed for use with optional speed controller.

cULus available on most models (optional).

Supply performance is obtained by reversing the direction of the venturi.



JencoFan, Div. of Soler & Palau Ventilation Group, certifies that the models GED & GSD are licensed to bear the AMCA Seal. The ratings shown are based on test and procedures performed in accordance with AMCA Publication 211 and AMCA Publication 311 and comply with the requirement of the AMCA Certified Ratings Program.



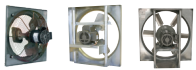

SIZE 18 (Continued on next page)

Motor HP	RPM	Sones @ 0" SP		Static Pressure in Inches w.g.								
				0	.10	.125	.25	.375	.50	.625	.75	
GED/GSD 1/4 HP 1075 RPM	775	4.6	CFM	2151	1703	1545	-	-	-	-	-	-
			BHP	0.08	0.09	0.09	-	-	-	-	-	-
	875	5.8	CFM	2428	2048	1935	-	-	-	-	-	-
			BHP	0.12	0.13	0.13	-	-	-	-	-	-
	975	7.0	CFM	2706	2378	2279	-	-	-	-	-	-
			BHP	0.17	0.17	0.19	-	-	-	-	-	-
	1075	8.3	CFM	2983	2686	2610	1986	-	-	-	-	-
			BHP	0.23	0.24	0.23	0.23	-	-	-	-	-
GED/GSD 1/4 HP 1625 RPM	625	2.9	CFM	1144	-	-	-	-	-	-	-	-
			BHP	0.01	-	-	-	-	-	-	-	-
	725	3.9	CFM	1327	-	-	-	-	-	-	-	-
			BHP	0.02	-	-	-	-	-	-	-	-
	825	5.0	CFM	1510	1119	826	-	-	-	-	-	-
			BHP	0.03	0.03	0.03	-	-	-	-	-	-
	925	6.0	CFM	1693	1351	1258	-	-	-	-	-	-
			BHP	0.04	0.04	0.04	-	-	-	-	-	-
	1025	7.1	CFM	1876	1575	1489	-	-	-	-	-	-
			BHP	0.06	0.06	0.06	-	-	-	-	-	-
	1125	8.3	CFM	2059	1786	1716	969	-	-	-	-	-
			BHP	0.08	0.08	0.08	0.08	-	-	-	-	-
	1225	9.5	CFM	2242	1990	1928	1487	-	-	-	-	-
			BHP	0.10	0.10	0.10	0.10	-	-	-	-	-
	1325	10.8	CFM	2425	2194	2135	1822	972	-	-	-	-
			BHP	0.12	0.13	0.13	0.13	0.13	-	-	-	-
1425	12.1	CFM	2608	2395	2338	2048	1410	-	-	-	-	
		BHP	0.15	0.16	0.16	0.16	0.16	-	-	-	-	
1525	13.5	CFM	2791	2595	2541	2280	1928	1101	-	-	-	
		BHP	0.19	0.20	0.20	0.20	0.20	0.20	-	-	-	
1625	14.8	CFM	2974	2792	2742	2500	2237	1524	902	-	-	
		BHP	0.23	0.24	0.24	0.24	0.24	0.24	0.24	0.24	-	
1675	15.7	CFM	3065	2889	2841	2607	2351	1800	1105	599	-	
		BHP	0.25	0.26	0.26	0.26	0.26	0.26	0.26	0.26	0.26	
1725	16.4	CFM	3156	2987	2940	2712	2460	2069	1316	777	-	
		BHP	0.27	0.29	0.29	0.29	0.29	0.29	0.29	0.29	0.29	
1750	16.8	CFM	3202	3035	2990	2764	2519	2181	1417	872	-	
		BHP	0.29	0.30	0.30	0.30	0.30	0.30	0.30	0.30	0.30	

Speed (RPM) shown is nominal. Performance is based on actual speed of test.
 Performance certified is for installation type A-free inlet, free outlet. Performance ratings do not include the effects of appurtenances (accessories).
 The sound ratings shown are loudness values in fan sones @ 5' (1.5m) in a hemispherical free field calculated per AMCA Standard 301. Installation Type A: free inlet hemispherical sone levels.

Motors designed for use with optional speed controller.

cULus available on most models (optional).

Supply performance is obtained by reversing the direction of the venturi.



JencoFan, Div. of Soler & Palau Ventilation Group, certifies that the models GED & GSD are licensed to bear the AMCA Seal. The ratings shown are based on test and procedures performed in accordance with AMCA Publication 211 and AMCA Publication 311 and comply with the requirement of the AMCA Certified Ratings Program.





SIZE 18 (Con't)

Motor HP	RPM	Sones @ 0" SP		Static Pressure in Inches w.g.								
				0	.10	.125	.25	.375	.50	.625	.75	
GED/GSD 1/2 HP 1625 RPM	625	2.8	CFM	1494	-	-	-	-	-	-	-	-
			BHP	0.03	-	-	-	-	-	-	-	-
	725	3.8	CFM	1733	1235	-	-	-	-	-	-	-
			BHP	0.04	0.04	-	-	-	-	-	-	-
	825	4.9	CFM	1972	1570	1444	-	-	-	-	-	-
			BHP	0.06	0.06	0.06	-	-	-	-	-	-
	925	6.0	CFM	2211	1877	1764	-	-	-	-	-	-
			BHP	0.09	0.09	0.09	-	-	-	-	-	-
	1025	7.2	CFM	2450	2152	2072	-	-	-	-	-	-
			BHP	0.12	0.12	0.12	-	-	-	-	-	-
	1125	8.3	CFM	2689	2419	2349	2112	-	-	-	-	-
			BHP	0.16	0.16	0.16	0.16	-	-	-	-	-
	1225	9.6	CFM	2928	2687	2616	2236	-	-	-	-	-
			BHP	0.21	0.21	0.21	0.21	-	-	-	-	-
	1325	10.8	CFM	3167	2950	2885	2549	-	-	-	-	-
			BHP	0.26	0.26	0.26	0.26	-	-	-	-	-
1425	12.2	CFM	3406	3210	3150	2860	2484	-	-	-	-	
		BHP	0.33	0.33	0.33	0.33	0.33	-	-	-	-	
1525	13.7	CFM	3646	3465	3412	3142	2808	-	-	-	-	
		BHP	0.40	0.40	0.40	0.40	0.40	-	-	-	-	
1625	15.1	CFM	3885	3718	3670	3414	3130	2780	-	-	-	
		BHP	0.48	0.49	0.49	0.49	0.49	0.49	-	-	-	
1675	16.0	CFM	4004	3844	3798	3548	3288	2981	-	-	-	
		BHP	0.53	0.53	0.53	0.53	0.53	0.53	-	-	-	
1725	16.9	CFM	4124	3969	3925	3680	3442	3140	2110	-	-	
		BHP	0.58	0.58	0.58	0.58	0.58	0.58	0.58	-	-	
1750	17.2	CFM	4183	4031	3988	3747	3516	3212	3127	-	-	
		BHP	0.61	0.61	0.61	0.61	0.61	0.61	0.61	-	-	

Speed (RPM) shown is nominal. Performance is based on actual speed of test.
 Performance certified is for installation type A-free inlet, free outlet. Performance ratings do not include the effects of appurtenances (accessories).
 The sound ratings shown are loudness values in fan sones @ 5' (1.5m) in a hemispherical free field calculated per AMCA Standard 301. Installation Type A: free inlet hemispherical sone levels.

Motors designed for use with optional speed controller.

cULus available on most models (optional).

Supply performance is obtained by reversing the direction of the venturi.



JencoFan, Div. of Soler & Palau Ventilation Group, certifies that the models GED & GSD are licensed to bear the AMCA Seal. The ratings shown are based on test and procedures performed in accordance with AMCA Publication 211 and AMCA Publication 311 and comply with the requirement of the AMCA Certified Ratings Program.





SIZE 20

Motor HP	RPM	Sones @ 0" SP		Static Pressure in Inches w.g.								
				0	.10	.125	.25	.375	.50	.625	.75	
GED/GSD 1/4 HP 1075 RPM	775	5.6	CFM	2495	1995	1830	-	-	-	-	-	-
			BHP	0.09	0.093	0.09	-	-	-	-	-	-
	875	6.9	CFM	2817	2391	2265	938	-	-	-	-	-
			BHP	0.13	0.133	0.13	0.13	-	-	-	-	-
	975	8.3	CFM	3139	2769	2661	1354	563	-	-	-	-
			BHP	0.18	0.184	0.18	0.18	0.18	-	-	-	-
	1,075	9.7	CFM	3461	3128	3040	2462	1169	-	-	-	-
			BHP	0.24	0.247	0.25	0.25	0.25	-	-	-	-
GED/GSD 1/2 HP 1625 RPM	625	2.8	CFM	1328	516	-	-	-	-	-	-	-
			BHP	0.03	0.026	-	-	-	-	-	-	-
	725	3.8	CFM	1540	865	668	-	-	-	-	-	-
			BHP	0.04	0.040	0.04	-	-	-	-	-	-
	825	4.8	CFM	1753	1238	1021	-	-	-	-	-	-
			BHP	0.06	0.059	0.06	-	-	-	-	-	-
	925	5.9	CFM	1965	1545	1393	595	-	-	-	-	-
			BHP	0.08	0.083	0.08	0.08	-	-	-	-	-
1025	6.9	CFM	2177	1826	1700	944	-	-	-	-	-	
		BHP	0.11	0.113	0.11	0.11	-	-	-	-	-	
1125	8.0	CFM	2390	2085	1984	1290	701	-	-	-	-	
		BHP	0.15	0.150	0.15	0.15	0.15	-	-	-	-	
1225	9.1	CFM	2602	2329	2248	1663	1050	555	-	-	-	
		BHP	0.19	0.193	0.19	0.19	0.19	0.19	-	-	-	
1325	10.3	CFM	2815	2563	2497	2025	1393	900	469	-	-	
		BHP	0.24	0.244	0.24	0.24	0.24	0.24	0.25	-	-	
1425	11.6	CFM	3027	2791	2735	2331	1754	1250	810	-	-	
		BHP	0.30	0.304	0.30	0.30	0.30	0.30	0.30	-	-	
1525	12.9	CFM	3240	3016	2965	2622	2131	1591	1159	764	-	
		BHP	0.37	0.373	0.37	0.37	0.37	0.37	0.37	0.37	-	
1625	14.3	CFM	3452	3240	3192	2898	2487	1949	1508	1110	-	
		BHP	0.45	0.451	0.45	0.45	0.45	0.45	0.45	0.45	-	
1675	15.0	CFM	3558	3351	3305	3030	2645	2135	1676	1285	-	
		BHP	0.49	0.494	0.49	0.49	0.49	0.49	0.49	0.49	-	
1725	15.7	CFM	3664	3462	3417	3160	2795	2323	1849	1460	-	
		BHP	0.54	0.539	0.54	0.54	0.54	0.54	0.54	0.54	-	
1750	16.1	CFM	3718	3517	3473	3223	3869	3419	1937	1547	-	
		BHP	0.56	0.563	0.56	0.56	0.56	0.56	0.56	0.56	-	

Speed (RPM) shown is nominal. Performance is based on actual speed of test.
 Performance certified is for installation type A-free inlet, free outlet. Performance ratings do not include the effects of appurtenances (accessories).
 The sound ratings shown are loudness values in fan sones @ 5' (1.5m) in a hemispherical free field calculated per AMCA Standard 301. Installation Type A: free inlet hemispherical sone levels.

Motors designed for use with optional speed controller.

cULus available on most models (optional).

Supply performance is obtained by reversing the direction of the venturi.



JencoFan, Div. of Soler & Palau Ventilation Group, certifies that the models GED & GSD are licensed to bear the AMCA Seal. The ratings shown are based on test and procedures performed in accordance with AMCA Publication 211 and AMCA Publication 311 and comply with the requirement of the AMCA Certified Ratings Program.





MODEL DFE & DFS CONSTRUCTION FEATURES

Model DFE & DFS

Entire Unit
Suitable for
all-angle installation.

Motor
Nationally recognized
brands, locally serviced.

Factory Run & Tested
For quality assurance and
dependable operation.

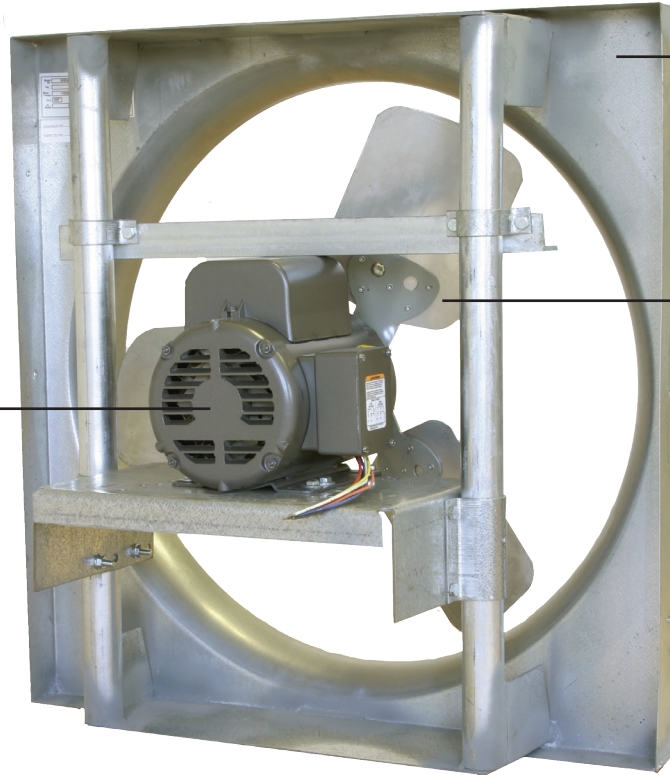

Panel
Galvanized steel
with spun venturi.

Propeller
Fabricated
Aluminum blades.

Mounting Holes
Prepunched in panel for
ease in installation.

Industry best 5 year fan housing warranty, 1 year motor warranty

Construction/Specification Checklist

Panel Assembly

- Galvanized steel, 16 or 18 gauge, G-90.
- Precision spun orifice for maximum performance.
- Prepunched mounting holes.
- Welded schedule 40 galvanized steel pipe support structure.

Propeller

- Precision pitched fabricated aluminum blades.
- Mounted directly on shaft for maximum efficiency.
- Cast aluminum and nonmetallic blade options on select sizes.
- Statically and dynamically balanced.

Motors

- Nationally recognized brands, locally serviced.
- Permanently lubricated sealed ball bearing type.
- Open drip-proof, totally enclosed and explosion proof options.
- Available 2 speed units in select models.

Entire Fan Unit

- Suitable for all-angle installation.
- Completely assembled and factory tested prior to shipment.

All specifications are subject to change without notice unless approved in submittal by JencoFan.

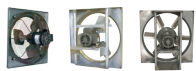

PERFORMANCE/DIMENSIONS

Model DFE (Exhaust) / DFS (Supply)

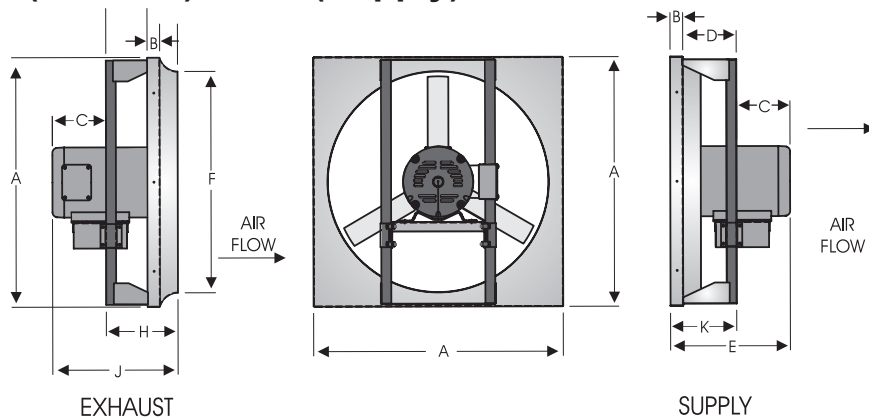

DFE/DFS Size	Dimensions (in.)											Avg. Ship Wt. (lbs.)
	A	B	C*	D	E*	F	G	H	I	J*	K	
10	16	1	6	6	11	10-1/2	2	8	5	14	7	30
12	16	1	6	6	11	12-1/2	2	8	5	14	7	30
16	20	1	6	6	12	16-1/2	2	8	5	14	7	37
18	24	1	6	6	12	18-1/2	2	8	5	14	7	45
20	24	1	7	6	12	20-1/2	2	8	5	15	7	50
24	30	2	10	9	21	25	3	10	4	20	11	70
30	36	2	10	9	21	31	3	10	4	20	11	100

- A. Outside dimension of square panel.
 - B. Width of flange.
 - C. Depth of motor beyond support structure.*
 - D. Depth of support structure - supply.
 - E. Depth of fan - supply.*
 - F. Diameter of venturi.
 - G. Depth of venturi.
 - H. Depth of panel and support structure - exhaust.
 - I. Depth of support structure - exhaust.
 - J. Depth of fan - exhaust.*
 - K. Depth of panel and support structure - supply.
- * Varies with motor selection

Model DFE/DFS	HP	RPM	Sones @ 0" SP	CFM / BHP @ Static Pressure (Inches W.G.)									
				0	1/10	1/8	1/4	3/8	1/2	5/8	3/4	1	
10	1/4	1750	8.4	6177/.04	532/.04	503/.04	3077/.06	181/.06	377/.07	-	-	-	
	2S	1160	5.5	409/.01	221/.02	178/.02	-	-	-	-	-		
12	1/4	1750	16.7	1306/.09	1199/.12	1169/.12	992/.12	734/.12	576/.14	488/.14	412/.13	275/.14	
	2S	1160	12.8	866/.03	682/.04	613/.04	347/.04	235/.04	132/.05	-	-	-	
16	1/3	1750	18.8	2439/.26	2309/.27	2274/.27	2208/.18	1872/.34	1633/.36	1350/.38	1152/.42	876/.43	
	2S	1160	11.7	1617/.08	1404/.09	1342/.09	974/.10	683/.12	491/.14	307/.15	132/.16	-	
18	3/4	1750	20	4174/.52	4021/.59	3982/.60	3781/.64	3564/.65	3321/.72	3029/.72	2468/.76	1977/.83	
	2S	1160	10.9	2767/.15	2531/.19	2468/.19	2102/.21	1504/.22	1085/.27	626/.28	264/.30	-	
20	1/3	1750	19.4	3649/.31	3455/.34	3409/.34	3177/.41	2635/.44	2634/.44	2635/.44	2344/.49	-	
	2S	1160	10.1	2418/.09	2134/.12	2063/.12	1639/.14	1153/.16	787/.17	509/.19	-	-	
24	1	1725	24	6008/.94	5788/1.01	5731/1.02	5431/1.06	5101/1.06	4734/1.13	4315/1.13	3835/1.17	2512/1.26	
	1 1/2	1725	40	6605/1.44	6383/1.44	6339/1.44	6061/1.44	5711/1.45	5279/1.36	4738/1.36	3885/1.26	2756/1.30	
	1/2	1750	14.7	4131/.31	3961/.37	3920/.38	3705/.45	3387/.50	3063/.59	2669/.68	2314/.68	-	
	2S	1160	7.7	2738/.09	2488/.13	2403/.13	1898/.17	1400/.21	-	-	-	-	
30	1/2	1750	18.4	5137/.37	4938/.43	4885/.45	4596/.53	4268/.63	3917/.67	3514/.76	2959/.92	2172/1.06	
	2S	1160	9.6	3405/.11	3083/.15	2989/.16	2459/.21	1700/.27	1196/.32	-	-	-	
	1	1725	32	6655/.76	6416/.87	6354/.87	6033/.95	5681/.96	5278/.99	4775/.99	4118/1.02	2407/1.14	
	3/4	1140	37	6684/.62	6252/.70	6140/.71	5525/.72	4686/.74	3221/.79	2031/.85	1287/.91	98/1.07	
30	1	1160	17.4	7464/.92	7015/.97	6898/.99	6267/1.01	5473/1.02	4052/1.08	2676/1.15	1820/1.19	-	
	1 1/2	1725	32	8897/1.48	8644/1.60	8579/1.62	8239/1.71	7870/1.74	7467/1.74	7020/1.80	6510/1.80	4703/1.80	
	1/2	1140	20	8427/.59	7520/.63	7288/.63	5939/.63	4108/.61	1455/.55	-	-	-	
	1	1140	27	10635/1.15	9468/1.12	9328/1.12	8205/1.12	6718/1.13	4175/1.10	1397/1.20	-	-	
30	1 1/2	1725	44	11570/1.68	11083/1.68	10956/1.68	10200/1.75	9323/1.74	8504/1.81	7625/1.74	6594/1.72	3905/1.67	
	2	1725	48	12415/1.89	11878/1.99	11723/2.01	10879/2.01	10141/2.01	9172/2.01	8172/2.01	7185/1.89	4705/1.84	

Performance shown is for wall ventilators for installation type A: Free inlet, Free outlet. The power rating (BHP) does not include drive losses. Performance ratings do not include the effects of appurtenances in the airstream.

Sound ratings shown are loudness values in fan sones at 5 feet (1.5m) in a hemispherical free field calculated per AMCA Standard 301. Values are for installation type A: Free inlet fan sone levels. For additional sound data and for selections at other static pressures, please refer to the Optimizer Selection Program.

Available motor RPM's may vary from table.

Supply performance is obtained by reversing the direction of the venturi.



MODEL DDE & DDS CONSTRUCTION FEATURES

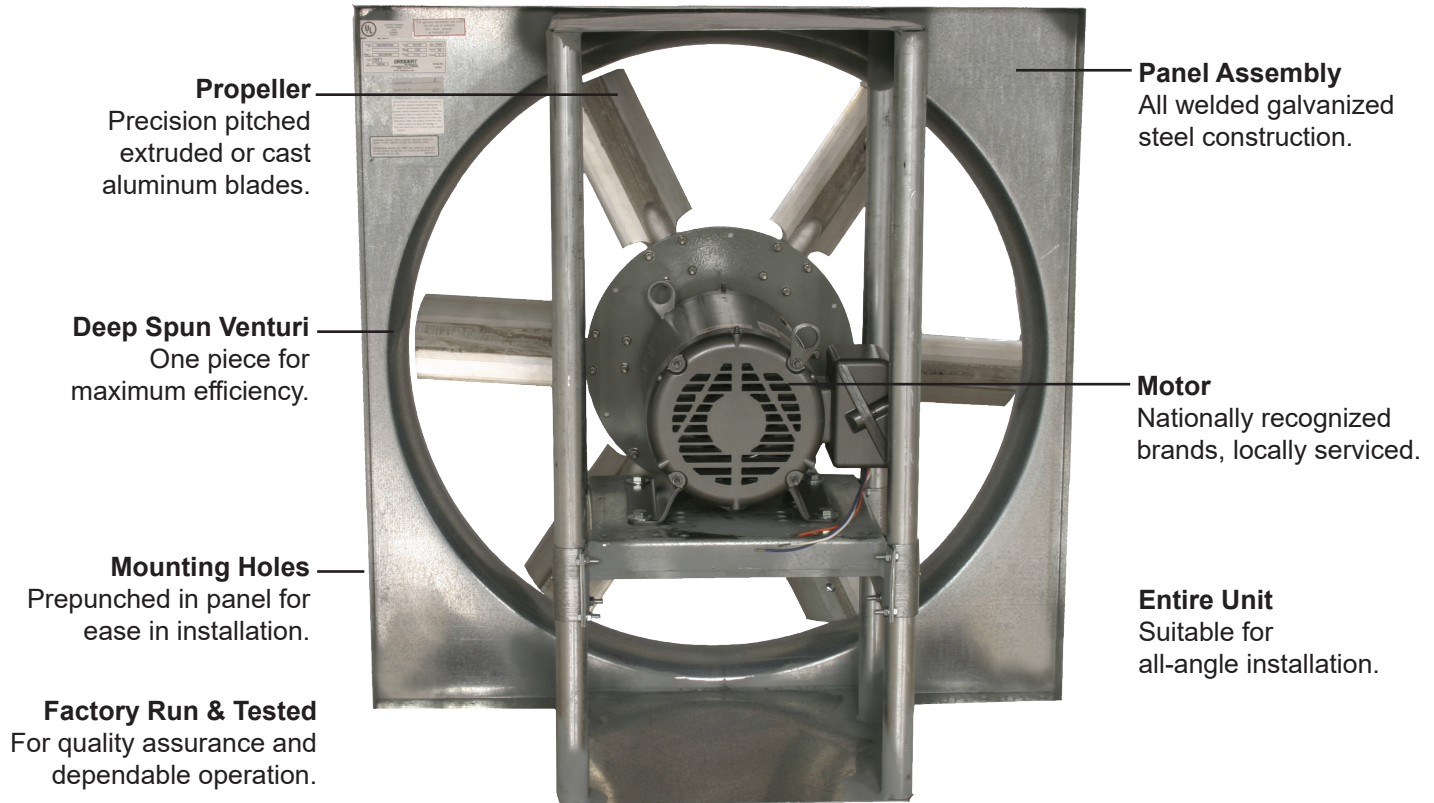

Industry best 5 year fan housing warranty, 1 year motor warranty

Construction/Specification Checklist

Panel Assembly

- Galvanized steel, 14 gauge, G-90, sizes 54-60.
- Galvanized steel, 16 gauge, G-90, sizes 24-48.
- Precision spun orifice for smooth performance.
- Prepunched mounting holes for convenient installation.
- Welded schedule 40 galvanized steel pipe support structure.

Propeller

- Aluminum airfoil blades, extruded or cast.
- Mounted directly on motor shaft for maximum efficiency.
- Steel hub plate with taper lock bushing as standard.
- Statically balanced.

Motors

- Nationally recognized brands, locally serviced.
- Sealed ball bearings on larger fractionals.
- 1/3 hp motor is the smallest available for the DDE/DDS.
- Open drip-proof, totally enclosed and explosion proof options.
- Available 2 speed units in select formats.

Entire Fan Unit

- Suitable for all-angle installation.
- Completely assembled and factory tested prior to shipment.

All specifications are subject to change without notice unless approved in submittal by JencoFan.

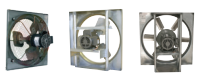

PERFORMANCE

Model DDE (Exhaust) / DDS (Supply)

Model DDE/DDS	MOTOR		Sones @ 0" SP	CFM / BHP @ Static Pressure (INCHES W.G.)								
	HP	RPM		0	1/10	1/8	1/4	3/8	1/2	5/8	3/4	1
24	1/3	1160	17.8	5600/.37	4960/.37	4800/.37	3600/.37	-	-	-	-	-
	1/2	1160	22	6600/.60	6200/.60	6100/.60	5400/.60	4300/.60	-	-	-	-
	3/4	1160	20	7800/.82	7240/.82	7100/.82	6300/.82	5400/.82	-	-	-	-
	1	1160	21	8700/1.09	8140/1.09	8000/1.09	7300/1.09	6300/1.09	4900/1.09	-	-	-
	1/2	1750	27	5900/.55	5420/.55	5300/.55	4700/.55	3900/.55	3000/.55	-	-	-
	3/4	1750	28	7000/.81	6600/.81	6500/.81	5900/.81	5300/.81	4400/.81	3500/.81	-	-
	1	1750	32	8000/1.15	7600/1.15	7500/1.15	7000/1.15	6300/1.15	5500/1.15	4700/1.15	3700/1.15	-
	1 1/2	1750	35	9000/1.66	8760/1.66	8700/1.66	8300/1.66	7900/1.66	7400/1.66	6900/1.66	6200/1.66	-
	2	1750	35	10500/2.25	10180/2.25	10100/2.25	9600/2.25	9100/2.25	8600/2.25	8100/2.25	7400/2.25	5900/2.25
3	1750	37	12500/3.30	12100/3.30	12000/3.30	11500/3.30	11100/3.30	10500/3.30	10000/3.30	9300/3.30	7900/3.30	
30	1	870	19.9	11700/1.12	10700/1.12	10450/1.12	8900/1.12	6300/1.12	-	-	-	-
	1 1/2	870	24	14300/1.65	13300/1.65	13050/1.65	11400/1.65	8850/1.65	5550/1.65	-	-	-
	3/4	1160	25	9900/.84	9020/.84	8800/.84	7500/.84	5700/.84	-	-	-	-
	1	1160	28	10600/1.16	10340/1.16	10054/1.16	9900/1.16	9478/1.16	9000/1.16	7900/1.16	6500/1.16	-
	1 1/2	1160	28	12800/1.67	12080/1.67	11900/1.67	10900/1.67	9800/1.67	8400/1.67	6700/1.67	-	-
	2	1160	29	14400/2.28	13680/2.28	13500/2.28	12400/2.28	11300/2.28	9800/2.28	7800/2.28	6000/2.28	-
	3	1160	36	17300/3.37	16660/3.37	16500/3.37	15600/3.37	14700/3.37	13000/3.37	11200/3.37	8600/3.37	-
	2	1750	44	13800/2.27	13160/2.27	13000/2.27	12200/2.27	11300/2.27	10400/2.27	-	-	-
	3	1750	55	14200/3.38	13800/3.38	13700/3.38	13200/3.38	12700/3.38	12100/3.38	11500/3.38	10700/3.38	9300/3.38
36	1	870	25	13000/1.14	12040/1.14	11800/1.14	10200/1.14	8200/1.14	6000/1.14	-	-	-
	1 1/2	870	26	16300/1.70	15180/1.70	14900/1.70	13200/1.70	11000/1.70	7900/1.70	-	-	-
	2	870	27	18500/2.23	17140/2.23	16800/2.23	15000/2.23	12900/2.23	9600/2.23	-	-	-
	3	870	32	21100/3.36	20060/3.36	19800/3.36	18100/3.36	15800/3.36	12800/3.36	9600/3.36	8100/3.36	-
	3/4	1160	30	11500/.85	10220/.85	9900/.85	8100/.85	6200/.85	-	-	-	-
	1	1160	31	13500/1.18	12460/1.18	12200/1.18	10700/1.18	8800/1.18	6500/1.18	-	-	-
	1 1/2	1160	33	15900/1.73	14780/1.73	14500/1.73	13000/1.73	11300/1.73	9200/1.73	-	-	-
	2	1160	39	15700/2.25	14980/2.25	14800/2.25	13800/2.25	12800/2.25	11600/2.25	10200/2.25	8500/2.25	-
	3	1160	40	20700/3.39	19900/3.39	19700/3.39	18600/3.39	17300/3.39	15900/3.39	14300/3.39	12300/3.39	-
42	5	1160	42	25100/5.49	24200/5.49	24000/5.49	22900/5.49	21700/5.49	20300/5.49	18700/5.49	16700/5.49	-
	7 1/2	1160	53	30500/8.15	29540/8.15	29300/8.15	28100/8.15	26700/8.15	25200/8.15	23400/8.15	21400/8.15	15500/8.15
	3	1750	58	18000/3.28	17200/3.28	17000/3.28	16000/3.28	15000/3.28	13900/3.28	12800/3.28	11600/3.28	9100/3.28
	5	1750	81	18600/5.42	18280/5.42	18200/5.42	17800/5.42	17300/5.42	16800/5.42	16200/5.42	15700/5.42	14500/5.42
	7 1/2	1750	75	27000/8.25	26360/8.25	26200/8.25	25400/8.25	24600/8.25	23600/8.25	22500/8.25	21500/8.25	19200/8.25
	1 1/2	870	36	17500/1.72	16140/1.72	15800/1.72	14100/1.72	12000/1.72	9500/1.72	7500/1.72	-	-
	2	870	36	19800/2.22	18520/2.22	18200/2.22	16200/2.22	14000/2.22	11000/2.22	8800/2.22	7200/2.22	-
	3	870	36	24500/3.26	22980/3.26	22600/3.26	20600/3.26	18000/3.26	14800/3.26	11200/3.26	9200/3.26	-
	5	870	40	31300/5.53	29780/5.53	29400/5.53	27300/5.53	24800/5.53	21800/5.53	17000/5.53	13200/5.53	-
48	3	1160	60	20500/3.30	19700/3.30	19500/3.30	18500/3.30	17300/3.30	15900/3.30	14400/3.30	13000/3.30	9700/3.30
	5	1160	61	28000/5.45	27200/5.45	27000/5.45	25800/5.45	24500/5.45	22800/5.45	20900/5.45	18900/5.45	13700/5.45
	7 1/2	1160	62	34500/8.26	33540/8.26	33300/8.26	32000/8.26	30600/8.26	28800/8.26	26800/8.26	24700/8.26	19400/8.26
	5	1750	89	26000/5.41	24960/5.41	24700/5.41	23500/5.41	22100/5.41	20700/5.41	19300/5.41	17900/5.41	-
	7 1/2	1750	94	32500/8.25	31700/8.25	31500/8.25	30300/8.25	29140/8.25	27800/8.25	26500/8.25	25200/8.25	-
	1 1/2	870	36	22800/1.68	20560/1.68	20000/1.68	16600/1.68	12100/1.68	-	-	-	-
	2	870	38	25900/2.25	23740/2.25	23200/2.25	19800/2.25	15800/2.25	-	-	-	-
	3	870	48	27000/3.37	25640/3.37	25300/3.37	23400/3.37	21100/3.37	18400/3.37	15200/3.37	-	-
	5	870	48	36000/5.57	34320/5.57	33900/5.57	31600/5.57	29000/5.57	25800/5.57	21900/5.57	17800/5.57	-
54	7 1/2	870	51	42100/8.14	40420/8.14	40000/8.14	37600/8.14	34900/8.14	31800/8.14	28000/8.14	22500/8.14	-
	10	870	63	46600/11.03	44920/11.03	44500/11.03	42200/11.03	39500/11.03	36100/11.03	32300/11.03	27500/11.03	20500/11.03
	3	1160	59	27000/3.29	25320/3.29	24900/3.29	22600/3.29	19800/3.29	17000/3.29	13800/3.29	11100/3.29	-
	5	1160	64	34700/5.54	33180/5.54	32800/5.54	30700/5.54	28400/5.54	26000/5.54	22900/5.54	19300/5.54	-
	7 1/2	1160	76	40500/8.12	38900/8.12	38500/8.12	36500/8.12	34000/8.12	31500/8.12	28700/8.12	25500/8.12	-
	10	1160	81	43400/10.81	42280/10.81	42000/10.81	40500/10.81	39000/10.81	37200/10.81	35200/10.81	33000/10.81	28000/10.81
	5	1750	75	37300/5.41	35220/5.41	34700/5.41	32000/5.41	29200/5.41	26100/5.41	23000/5.41	19600/5.41	-
	7 1/2	1750	79	46000/8.21	44320/8.21	43900/8.21	41700/8.21	39200/8.21	36400/8.21	33000/8.21	29500/8.21	-
	10	1750	86	51600/11.00	49920/11.00	49500/11.00	47300/11.00	44800/11.00	42200/11.00	39300/11.00	36200/11.00	-
60	7 1/2	870	77	49000/8.25	47000/8.25	46500/8.25	43900/8.25	41100/8.25	37700/8.25	34200/8.25	30500/8.25	22700/8.25
	10	870	77	55800/10.33	53800/10.33	53300/10.33	50500/10.33	47300/10.33	43600/10.33	39800/10.33	35700/10.33	27000/10.33

Performance shown is for wall ventilators for installation type A: Free inlet, Free outlet. The power rating (BHP) does not include drive losses. Performance ratings do not include the effects of appurtenances in the airstream.

Sound ratings shown are loudness values in fan sones at 5 feet (1.5m) in a hemispherical free field calculated per AMCA Standard 301. Values are for installation type A: Free inlet fan sone levels.

For additional sound data and for selections at other static pressures, please refer to the Optimizer Selection Program. Available motor RPM's may vary from table. Supply performance is obtained by reversing the direction of the venturi.



DIMENSIONS

Model DDE & DDS

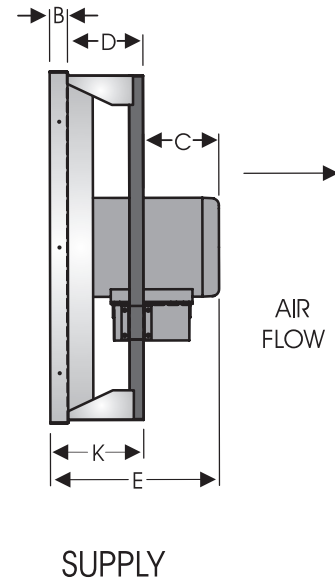
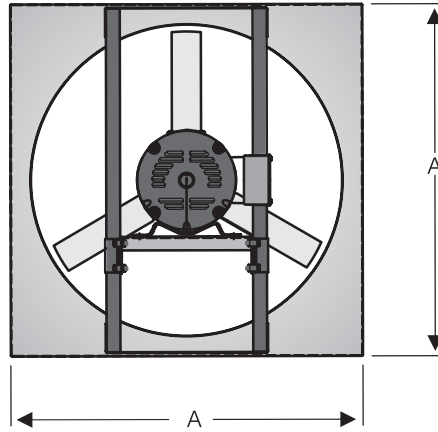
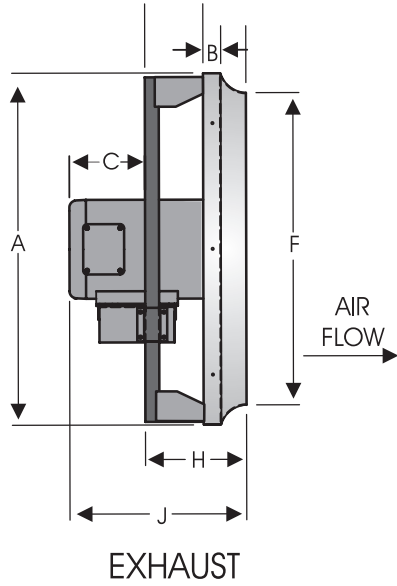

DDE/ DDS Size	Dimensions (in.)										
	A	B	C*	D	E*	F	G	H	I	J	K
24	30	2	11	9	21	25	3	9	4	20	11
30	36	2	11	9	21	31	3	9	4	20	11
36	42	2	11	9	21	37	3	9	4	20	11
42	48	2	11	9	21	43	3	9	4	20	11
48	54	2	12	10	23	49-1/4	4	10	4	22	12
54	60	2	13	11	25	55-1/4	5	11	4	24	13
60	66	2	13	11	25	61-1/4	5	11	4	24	13

- A. Outside dimension of square panel.
 - B. Width of flange.
 - C. Depth of motor beyond support structure.*
 - D. Depth of support structure - supply.
 - E. Depth of fan - supply. *
 - F. Diameter of venturi.
 - G. Depth of venturi.
 - H. Depth of panel and support structure - exhaust.
 - I. Depth of support structure - exhaust.
 - J. Depth of fan - exhaust.*
 - K. Depth of panel and support structure - supply.
- * Varies with motor selection**