

WALL MOUNTING KIT ASSEMBLY INSTRUCTIONS

MODELS: TXBW & TXDW

JencoFan

6393 Powers Avenue
Jacksonville, Florida 32217-2298
P: 904.731.4711 / F: 904.737.8322
www.Jencofan.com

Soler&Palau
Ventilation Group

The centrifugal power roof ventilators model TXB (belt drive) and TXD (direct drive) can be factory ordered as wall mount or converted to wall mount units by field installing internal motor/bracket gusset and/or an external shroud support strap.

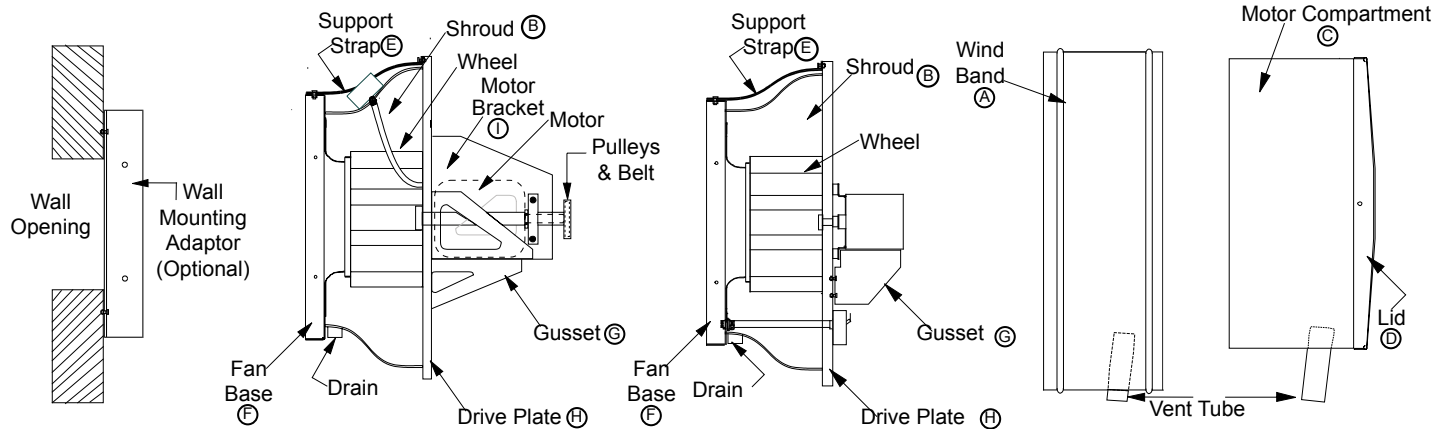

PARTS LIST - PART # (QTY)					
TXB WALL MOUNT KITS (BELT DRIVE)			TXD WALL MOUNT KITS (DIRECT DRIVE)		
Kit includes: Wall mount strap, gusset, upper support strap, flange nuts & bolts		Optional Wall Mount Adaptor	Kit includes: Wall mount gusset, upper support strap and flange bolts.		Optional Wall Mount Adaptor
6 & 8	#100401	700708-2	6 (1)	#100409	700708-2
10	#100402	700708-2	8 (1)	#100408	700708-2
12 & 15	#100403	700709-2	10	#100406	700708-2
18 & 20	#100404	700710-2	12, 14, 15	#100407	700709-2
24	#100405	700711-2	1515	#100410	700709-2

(1) Gusset not required on TXD 6" & 8" units.

INSTALLATION / ASSEMBLY INSTRUCTIONS:

Disconnect electrical power before servicing or assembling. Place the unit on a table or other stable surface.

1. Remove cotter pin & slide vent tube out.
2. Remove windband (A) from lower shroud (B) by removing eight (8) number 14 SS screws.
3. Remove motor compartment (C) and Lid (D) by removing four (4) number 14 SS screws.
4. Attach support strap (E) to fan base (F) by bolting thru the fan base with a 5/16 bolt & locking in place with a 5/16 nut on the outside of base.
5. To attach top end of support strap (E) to shroud by placing 5/16 bolt thru strap and shroud, then lock in place with 5/16 nut on the inside of shroud flange.
6. Attach gusset (G) to motor drive plate (H) (direct drive). Attach gusset (G) to drive support plate (H) (belt drive) and to motor bracket (I) with 5/16 X 1" bolts. Bolt the direct drive gusset to the drive plate only.
7. Bolt belt drive gusset to drive plate with bolt coming thru the drive plate and the locknut on top side of drive plate and gusset.
8. Re-assemble housing (steps 3, 2 then 1) using care not to damage the threaded fasteners by overtightening.

Only a qualified professional should perform the fan installation. **IMPORTANT:** The fan must be installed with the drain and vent tube on the underside of the fan for weather protection and proper operation.

For additional safety precautions please refer to AMCA Bulletin #410 "Recommended Safety Practices for Users and Installers of Industrial and Commercial Fans".