

### STANDARD CONSTRUCTION FEATURES

- All aluminum exterior construction.
- Stainless steel exterior fasteners.
- Ventilated motor compartment.
- Prepunched curb cap with welded corners.
- Aluminum nonoverloading wheel.
- Adjustable V-Belt drive.
- Motor & drive factory mounted (except 182T and larger).
- Mounted service disconnect (except 2 speed and XP motors).
- Pillow block ball bearings (L50 = 200k with lube fittings).
- Internal wiring chase.
- Aluminum birdscreen and windband.
- Neoprene vibration isolators.

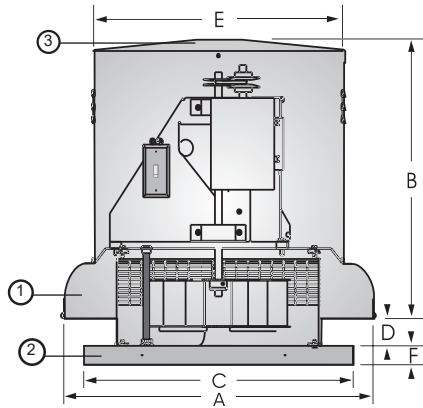

SIZE	DIMENSIONS (IN.)						Damper OD	MIN. METAL THICKNESS (ALUM.)			AVG. SHIP WT. LBS.
	A	B	C	D	E	F		SKIRT ①	CURB CAP ②	LID COVER ③	
36	58 3/8	37	42 1/2	10	41	2 1/2	36	.100	.090	.050	475
42	73	40 1/2	55	10	54 5/8	2 1/2	48	.100	.090	.050	700
48	73	40 1/2	55	13	54 5/8	2 1/2	48	.100	.090	.050	830

A - Skirt OD (Dia). E - Motor cover OD (Dia).  
 B - Height. F - Curb cap flange.  
 C - Curb cap OD.  
 D - Skirt height.

DIMENSIONS REPRESENT GENERAL CONSTRUCTION AND MAY VARY SLIGHTLY. CONTACT FACTORY FOR CERTIFIED DRAWINGS.

FAN SPECIFICATIONS									MOTOR SPECIFICATIONS				
Line	Qty.	Model No.	Tag	CFM	SP	Fan RPM	BHP	Sones	HP	Volts	Phase	Hertz	Encl
1													
2													
3													
4													
5													

ACCESSORY ITEMS	1	2	3	4	5	ACCESSORY ITEMS	1	2	3	4	5
<input type="checkbox"/>						<input type="checkbox"/>					
<input type="checkbox"/>						<input type="checkbox"/>					
<input type="checkbox"/>						<input type="checkbox"/>					
<input type="checkbox"/>						<input type="checkbox"/>					
<input type="checkbox"/>						<input type="checkbox"/>					

For more information contact us at [www.solerpalau-usa.com](http://www.solerpalau-usa.com) or 1.800.961.7370 for additional submittal drawings.

JencoFan will not be responsible for fabrication changes or errors resulting from customer use of a non-current submittal drawing.