

MODEL TUB

TUBEAXIAL UPBLAST PROPELLER ROOF EXHAUSTER



MODEL FEATURES

- Exhaust air up to 60,116 CFM in static pressure applications up to 1" w.g.
- Straight-through air flow design results in maximum exhaust efficiency
- Motor and drives are located outside of the exhaust airstream
- Belt drives permit easy performance adjustments when needed
- cULus 705 Listed

MODEL OVERVIEW

Model TUB is designed for high capacity industrial and commercial roof exhaust applications. The remote drive configuration of the TUB is especially suited for the removal of fumes, vapors, steam, dust, smoke and contaminated or heated air. Belt drive models are available for continuous operation in air temperatures to 200°F. For temperature ratings to 1000°F and/or IRI requirements refer to Model TUB-HT

Capacities range from 6,210 to 60,116 CFM and up to 1" static pressure. Fan selections are available in 24, 30, 36, 42, 48, 54 and 60 inch sizes. Horsepowers range from 3/4 to 15HP. Blade selections are available in aluminum, steel, or fiberglass reinforced polypropylene (see capacity charts for performances). Units are tested in accordance with AMCA 301 (sound) and AMCA 210 (air) in an AMCA certified laboratory. Every unit is completely assembled and factory tested for quality assurance prior to shipment.

2 year fan housing warranty, 1 year motor warranty



CONSTRUCTION FEATURES AND OPTIONS

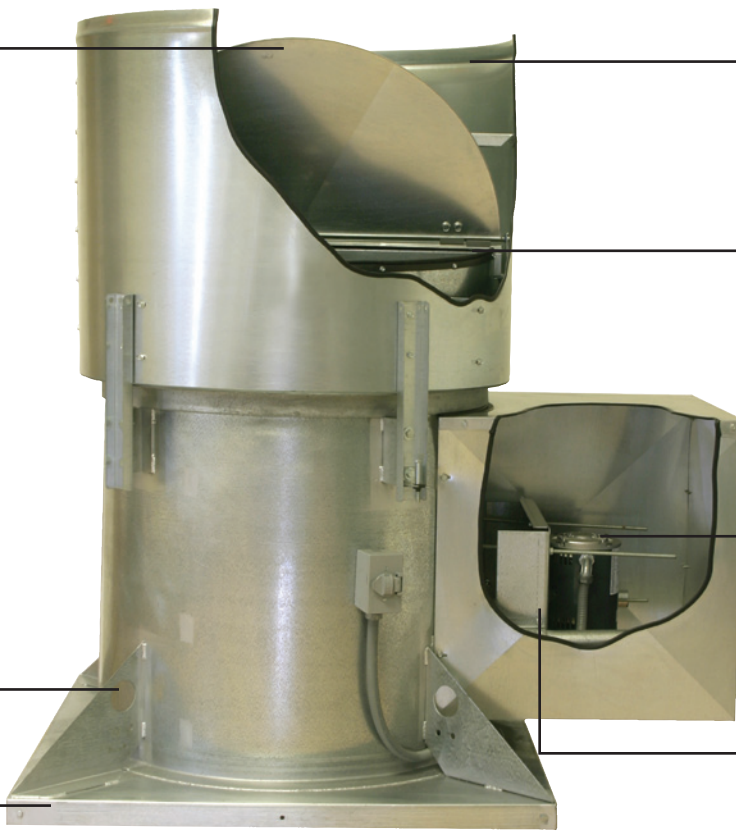

Butterfly Dampers

Available in steel or fiberglass.

Blades

Statically and dynamically balanced aluminum airfoil extrusion or polypropylene propellers for optimum performance. High temperatures fans use steel blades.

Damper Bearings

Damper doors pivot on a galvanized steel shaft rotating in two bronze bushings.

Lift Points

For easy, safe roof placement.

Curb Cap

Heavy-gauge galvanize with integral inlet.

Bearings & Shaft

200,000 hour bearings and turned, ground and polished shafting.

Factory Run & Tested

Assures dependable operation.

Windband

Heavy-gauge galvanized steel.

Rain Channel

Galvanized metal channel section drains water out of the fan area when the damper doors are closed.

Motors

ODP, 2-speed, TEFC, corrosion duty, or explosion proof.

Motor Slide Base

For ease of belt adjustment.

Drives

Variable pitch through 3HP and fixed pitch sheaves 5HP and larger. High temperature fan uses minimum dual groove sheaves.

CONSTRUCTION/SPECIFICATION CHECKLIST

Construction

The TUB series is built with heavy-gauge steel to provide years of reliable service. Tubes 24-60" (to 10HP) are G-90 galvanized steel. Sizes 24-60" have rolled 2" flanged ends.

The TUB series is also available in aluminum construction sizes 24-48" with welded aluminum angle flanges on each end.

Upblast fans include a heavy-gauge galvanized steel windband with pressure operated damper doors. A galvanized channel section drains water out of the fan area when the damper doors are closed.

All fans are available in epoxy, heresite or polyester resin finishes. Special colors can be ordered. Contact your representative for the cost and finish best suited for your application.

Blades

For versatility, blades are offered in special high-strength, adjustable pitch aluminum airfoil, or adjustable pitch fiberglass reinforced polypropylene. TUB units with special steel blades are available upon request. These styles were selected to provide optimum performance and strength at low to moderate noise levels. Refer to the performance tables for the best selection.

The adjustable pitch aluminum airfoil propeller performs over a wide range of static pressures. This blade's strength is derived from matching T-6061 extruded aluminum airfoil sections to a heavy steel plate hub. All JencoFan blades are statically and dynamically balanced.

The highly corrosive resistant polypropylene blade's efficiency is due to the uniform twisting of the airfoil section over its entire length, resulting in less turbulence. The operating parameters are -40°F to 185°F ambient temperatures. Hubs are produced from die cast aluminum resulting in a light weight, high strength factory adjustable pitch blade.

Drives

This belt drive model comes with 200,000 hour L50 relubricable pillow block bearings and remote grease lines as a standard feature. Bearings and drives are isolated from the airstream by bolted, heavy-gauge galvanized belt tubes and bearing covers. Belt drive models through 3HP ship with variable pitch pulleys; over 3HP have fixed pulleys. The motor base slides for easy belt adjustment. All units are factory assembled and test run for quality assurance.

Motors

Motors used in the TUB series are heavy-duty, nationally recognized, with nationwide service centers. Standard motors are open drip-proof (ODP). High efficiency, totally enclosed fan cooled (TEFC), explosion proof, and corrosion duty motors are available as an option.

Fan shafts shall be turned, ground and polished steel coated with an anti-rust compound to resist corrosion.

OPTIONS/ACCESSORIES

Roof Curb: Prefabricated heavy-gauge galvanized steel, welded construction, 12” high with 1-1/2” wood nailer. Options include burglar bars, single and double pitch construction, and additional curb heights.

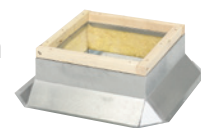

Outlet Guard: 1/2” x 1” wire mesh guard will prevent birds and other objects from entering fan.

Inspection Door: For inspection and blade service/cleaning.

Magnetic Latches: Helps reduce damper chatter when the unit is not in operation.

Heat/Smoke Vent: Opens damper doors when temperatures exceed 165°F. Allows heat and smoke to escape building without use of fan power.

Disconnect Switch: Nonfused safety disconnects are available for all motor sizes in rain-tight or open enclosures.

Aluminum Construction: Optional aluminum construction available on windbands, curb caps, panel and blades.

Special Coatings: Powered roof exhausters often require special coatings for protective and decorative purposes. Available coatings include: Synthetic Resin, Epoxy, and Heresite (air-dried phenolic). Contact your representative or the factory for more information on available coatings and colors.

DIMENSIONS

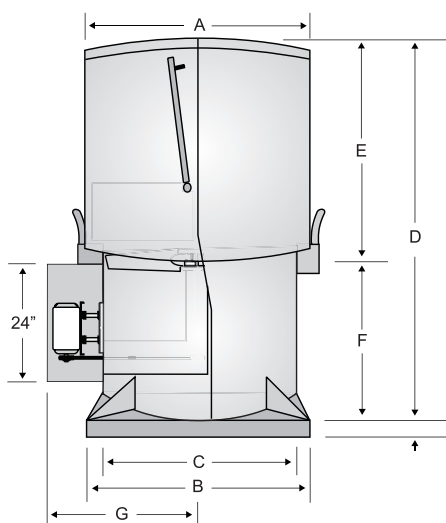

Model TUB	Dimensions (Inches)						
	A O.D. Windband	B sq. I.D. Curb Cap	C sq. Min. I.D. Opg	D Height	E Windband Height	F Tube Height	G (Max.)
24	30	35	25-1/8	55-1/2	25	30-1/2	37
30	36	41	31-1/8	58-1/2	28	30-1/2	40
36	42	47	37-1/8	60-1/2	30	30-1/2	43
42	48	53	43-1/8	65-1/2	33	32-1/2	46
48	54	59	49-1/8	68-1/2	36	32-1/2	49
54	60	65	55-1/8	71-1/2	39	32-1/2	52
60	66	71	61-1/8	74-1/2	42	32-1/2	55

Model TUB	Metal Gauges			Average Weight
	Fan Housing	Wind Shroud	Curb Cap	
24	12	18	14	500
30	12	18	14	600
36	12	18	14	1000
42	12	18	14	1100
48	10	18	14	1300
54	10	18	14	1580
60	10	18	10	1700

**PERFORMANCE****Model TUB-A - Belt Drive - Aluminum Blade**

Model TUB	CFM / BHP @ Static Pressure								HP	RPM	No. of Blades	Max. BHP	Sones @ 5 ft.
	0	1/8	1/4	3/8	1/2	5/8	3/4	1					
24	6210	5807	5171	4321	-	-	-	-	3/4	1200	3	0.83	19
	6805	6443	5948	5201	4415	-	-	-	1	1315	3	1.09	24
	7840	7537	7162	6651	5979	5306	4519	-	1-1/2	1515	3	1.65	29
	8668	8398	8081	7688	7156	6544	5936	4531	2	1675	3	2.22	38
30	9035	8175	6911	-	-	-	-	-	3/4	915	3	0.83	23
	9973	9213	8219	6789	-	-	-	-	1	1010	3	1.11	24
	11405	10755	9989	8955	7664	6304	-	-	1-1/2	1155	3	1.65	32
	12590	12009	11351	10554	9495	8312	7079	-	2	1275	3	2.21	38
	14318	13813	13262	12642	11903	10974	9935	7778	3	1450	3	3.22	45
36	13854	12440	10596	-	-	-	-	-	1	815	3	1.10	20
	15894	14689	13275	11404	9161	-	-	-	1-1/2	935	3	1.66	26
	17424	16337	15110	13611	11713	9660	-	-	2	1025	3	2.19	30
	19719	18769	17734	16568	15162	13476	11652	-	3	1160	3	3.14	36
	23798	23021	22201	21324	20373	19306	18074	15197	5	1400	3	5.47	68
	27028	26347	25639	24897	24114	23277	22371	20220	7-1/2	1590	3	7.97	89
42	14588	-	-	-	-	-	-	-	3/4	550	4	0.84	22
	16046	14024	11621	-	-	-	-	-	1	605	4	1.04	23
	18300	16539	14632	12265	-	-	-	-	1-1/2	690	4	1.57	24
	20157	18561	16898	14949	12723	-	-	-	2	760	4	2.11	29
	23074	21682	20029	18749	16978	15038	12727	-	3	870	4	3.28	36
	27349	26140	24961	23751	22474	21049	19441	15994	5	1030	4	5.17	45
	32037	30976	29849	28647	27358	25974	24473	21207	7-1/2	1310	3	7.87	57
48	20266	16694	-	-	-	-	-	-	1	500	4	1.12	24
	23104	20044	16726	-	-	-	-	-	1-1/2	570	4	1.67	25
	25536	22821	19815	16733	-	-	-	-	2	630	4	2.25	26
	29184	26863	24237	21647	18899	14356	-	-	3	720	4	3.33	35
	34656	32749	30623	28375	26210	23907	21375	-	5	855	4	5.51	43
	39519	37871	36068	34141	32163	30271	28304	23692	7-1/2	975	4	7.88	51
54	45327	43576	41742	39672	37424	35052	32652	28246	10	1175	4	10.87	73
	31028	26996	23045	19851	-	-	-	-	3	600	4	3.09	33
	38951	35127	30055	26760	24164	18353	-	-	5	710	4	5.32	44
	44741	41411	37455	32829	29414	26206	20758	-	7-1/2	850	3	7.91	54
60	49215	46040	42878	38781	34681	31975	29019	18913	10	935	3	10.89	62
	33008	22992	-	-	-	-	-	-	3	485	3	3.15	38
	39133	31577	24734	-	-	-	-	-	5	575	3	5.18	39
60	44918	38963	30343	27344	-	-	-	-	7-1/2	660	3	8.15	51
	49342	44124	36563	31592	-	-	-	-	10	725	3	10.93	59

Contact factory for alternate selections if required.

The sound ratings shown are loudness values in fan sones at 5 ft. (1.5m) in a hemispherical free field calculated per AMCA Standard 301 @ free air.

Brake horsepower does not include drive losses.

Values are installation Type A, free inlet fan sone levels.

Performance shown is for types and units without inlet or outlet ducts.

**Model TUB-P - Belt Drive - Polypropylene Blade**

Model TUB	CFM / BHP @ Static Pressure								HP	RPM	No. of Blades	Max. BHP	Sones @ 10 ft.
	0	1/8	1/4	3/8	1/2	5/8	3/4	1					
24	6350	5962	5491	4980	-	-	-	-	3/4	1275	6	0.75	17
	6998	6680	6180	5755	5268	4595	-	-	1	1390	6	1.00	20
	8265	7943	7615	7267	6873	6421	5382	-	1-1/2	1615	6	1.50	26
	9246	8996	8697	8408	8190	7731	6942	5382	2	1800	6	2.00	36
	10626	10323	10121	9875	9619	9342	8731	8042	3	2050	6	3.00	39
30	8697	7942	6919	-	-	-	-	-	3/4	975	6	0.75	19
	9775	9121	8323	7321	-	-	-	-	1	1080	6	1.00	20
	11515	10920	10321	9646	8797	7870	-	-	1-1/2	1250	6	1.50	24
	12821	12222	11727	11224	10523	9719	7823	-	2	1375	6	2.00	26
	14525	14029	13623	13124	12628	12031	10741	8914	3	1550	6	3.00	34
	17514	17112	16694	16301	15913	15491	14631	13585	5	1850	6	5.00	52
36	14809	13921	12488	11222	8630	-	-	-	1-1/2	930	6	1.50	24
	16823	16002	14911	13692	12481	10275	-	-	2	1040	6	2.00	28
	19331	18540	17681	16791	15710	14722	11081	-	3	1180	6	3.00	34
	22940	22026	21560	20890	20018	19230	17450	15008	5	1385	6	5.00	39
	26230	25850	25120	24562	23900	23243	21900	20144	7-1/2	1585	6	7.50	50
	29020	28671	28028	27670	27016	26560	25048	24010	10	1750	6	10.00	71
42	17451	15670	13561	10019	-	-	-	-	1-1/2	750	6	1.50	20
	19563	17981	16195	14986	10126	8126	-	-	2	825	6	2.00	32
	22893	21562	20128	18673	16892	14457	-	-	3	950	6	3.00	33
	27670	26551	25253	24030	22968	21616	18018	12775	5	1130	6	5.00	39
	31120	30830	30039	29130	28312	27022	24790	21100	7-1/2	1300	6	7.50	50
	34310	33537	32610	31674	30880	29868	27986	25708	10	1420	6	10.00	53
48	20303	18249	15126	-	-	-	-	-	1-1/2	620	8	1.50	24
	21414	19321	16364	-	-	-	-	-	2	650	8	2.00	26
	25236	23381	21684	19291	16061	-	-	-	3	750	8	3.00	28
	30791	29108	27464	25852	24142	22122	15276	-	5	890	8	5.00	36
	35748	34126	32561	31213	29792	28382	24298	18203	7-1/2	1015	8	7.50	50
	39574	38235	36780	35453	34243	33033	30691	26405	10	1120	8	10.00	55
54	31896	28991	24252	-	-	-	-	-	3	600	6	3.00	26
	34454	33006	31283	28892	25962	22632	-	-	5	730	8	5.00	33
	40051	38596	37383	35663	33543	31323	25762	-	7-1/2	835	8	7.50	39
	44750	43544	42334	41124	39504	37683	33343	28192	10	925	8	10.00	43
	51252	50115	49105	48094	46974	45764	42334	38593	15	1040	8	15.00	56
	60	44454	40914	37683	33704	28292	-	-	-	5	640	6	5.00
52235		49105	46274	43344	40015	35963	-	-	7-1/2	735	6	7.50	39
58295		55465	52735	50015	47484	44354	-	-	10	810	6	10.00	50
60116		58695	57185	55565	54055	52535	49205	45164	15	926	8	15.00	56

Contact factory for alternate selections if required.

The sound ratings shown are loudness values in fan sones at 5 ft. (1.5m) in a hemispherical free field calculated per AMCA Standard 301 @ free air.

Brake horsepower does not include drive losses.

Values are installation Type A, free inlet fan sone levels.

Performance shown is for types and units without inlet or outlet ducts.

MODEL TUB-HT

TUBEAXIAL UPBLAST PROPELLER ROOF EXHAUSTER FOR HEAT AND SMOKE REMOVAL



MODEL FEATURES

- Exhaust air up to 57,000 CFM in static pressure applications up to 3/4" w.g.
- Motor and drives are located outside of the exhaust airstream
- Designed and tested for emergency heat and smoke removal
- Successfully passed heat test of 1000°F for 15 minutes and 500°F for over 4 hours
- Belt drives permit easy performance adjustments when needed
- UL 793 Listed as Power Ventilator for Smoke Control Systems

MODEL OVERVIEW

Model TUB-HT has been designed and tested for emergency heat and smoke removal. This design also lends itself to everyday nonemergency high capacity industrial and commercial roof exhaust applications. Model TUB-HT successfully passed heat test of 1000°F for fifteen (15) minutes, and 500°F for over four (4) hours by an independent testing agency. Model TUB-HT exceeds I.R.I (Industrial Risk Insurers) guidelines and is UL-793 Listed as "Power Ventilator for Smoke Control Systems."

The heavy-gauge design allows for years of standard commercial use and the dependability required in a fire emergency. The upblast configuration exhausts heat and smoke high above the roof line aiding in the access and capabilities of fire fighters. Unlike complete design dependence on gravity vents which are sometimes limited by air temperature and wind velocity, the TUB-HT in conjunction with gravity vents, will more effectively remove smoke, hot air, and gases when used in a properly designed system. In the event of electrical failure, the 165°F fusible link will activate the spring assisted damper doors to provide gravity ventilation. Fan CFM, sizing and location for both exhaust and supply air are an important part of the overall heat and smoke venting building design needs. Refer to I.R.I., NFPA (National Fire Protection Association), and local fire codes for help in proper system design. Final approval for the complete system design should be authorized by the local authority having jurisdiction.

Fan selections are available in 24, 30, 36, 42, 48, 54 and 60 inch sizes. Horsepower and CFM range to 57,000 CFM and 15HP. Units are tested in accordance with AMCA Standard 301 (sound) and AMCA 210 (air) in an AMCA certified laboratory. Every unit is completely assembled and factory tested for quality assurance prior to shipment.

1 year fan housing warranty, 1 year motor warranty



CONSTRUCTION/SPECIFICATION CHECKLIST

1. Successfully heat tested by independent laboratory for:
 - (a) 1000°F for 15 minutes.
 - (b) 500°F for minimum 4 hours.
2. All ferrous construction in airstream.
3. 165°F fusible link in damper mechanism (heat & smoke vent).
4. Motor out-of-airstream design.
5. Belt & bearings enclosed in ventilated housing.
6. Minimum dual groove drive/belt combination.
7. Shaft heat slinger.
8. Extended lubrication lines.
9. UL-793 Listed Power Ventilator for Smoke Control Systems.
10. Meets UL-793 snow load test.

Drives

Motors, bearings and belt are shielded from the airstream by a sheet metal enclosure, with cooling provided by fresh outside air. Drives are sized for a minimum 150% of drive horsepower. Drives are minimum dual groove sheaves through 10 horsepower and three-belt on 15HP. Adjustable sheaves are available as an option. Bearings are heavy-duty cast iron, pillow block with relubricable fittings. Standard bearings are fitted with remote relubricable fittings and designed for minimum 200,000 hour life. All shafts are turned, ground and polished steel coated with an anti-rust compound to resist corrosion.

Electrical Power

Electrical power should be independent of the general building. Wiring requires special, heat resistant qualities as determined by local fire codes. Switching should always be arranged so that automatic start-up can be achieved through safety devices such as, but not limited to, sprinkler systems and smoke or heat sensors.

OPTIONS/ACCESSORIES

Roof Curb: Prefabricated heavy-gauge galvanized steel, welded construction, 12" high with 1-1/2" wood nailer. Options include burglar bars, single and double pitch construction, and additional curb heights.

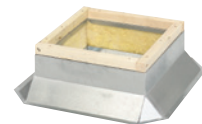

Outlet Guard: 1/2" x 1" wire mesh guard will prevent birds and other objects from entering fan.

Inspection Door: For inspection and blade service/cleaning.

Disconnect Switch: Nonfused safety disconnects are available for all motor sizes in rain-tight or open enclosures.

Special Coatings: Powered roof exhausters often require special coatings for protective and decorative purposes. Available coatings include: Synthetic Resin, Epoxy, and Heresite (air-dried phenolic). Contact your representative or the factory for more information on available coatings and colors.



DIMENSIONS

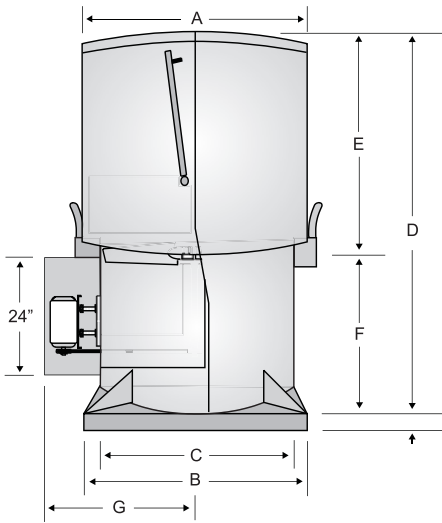

Model TUB-HT	Dimensions (Inches)						
	A O.D Windband	B sq. I.D. Curb Cap	C sq. Min. I.D. Opg	D Height	E Windband Height	F Tube Height	G (Max.)
24	30	35	25-1/8	55-1/2	25	30-1/2	37
30	36	41	31-1/8	58-1/2	28	30-1/2	40
36	42	47	37-1/8	60-1/2	30	30-1/2	43
42	48	53	43-1/8	65-1/2	33	32-1/2	46
48	54	59	49-1/8	68-1/2	36	32-1/2	49
54	60	65	55-1/8	71-1/2	39	32-1/2	52
60	66	71	61-1/8	74-1/2	42	32-1/2	55

Model TUB-HT	Metal Gauges			Average Weight
	Fan Housing	Wind Shroud	Curb Cap	
24	12	18	14	500
30	12	18	14	600
36	12	18	14	1000
42	12	18	14	1100
48	10	18	14	1300
54	10	18	14	1580
60	10	18	10	1700

**PERFORMANCE DATA****TUB-HT - Belt Drive - Steel Blade**

Model TUB-HT	CFM / BHP @ Static Pressure							HP	RPM	Max. BHP	Sones @ 5 ft.
	0	1/8	1/4	3/8	1/2	5/8	3/4				
24	6255	5297	4821	4035	-	-	-	3/4	1215	0.78	21
	6962	6547	6115	5446	-	-	-	1	1275	1.08	25
	7896	7272	6601	6216	5814	5248	-	1-1/2	1530	1.53	31
	8693	8109	7688	7265	6276	5409	-	2	1750	2.05	40
30	9631	8703	6835	6478	-	-	-	1	1180	1.06	26
	11324	10716	9408	7755	6574	-	-	1-1/2	1155	1.57	29
	11952	11272	10694	9776	8405	7824	-	2	1550	2.09	35
	13871	13059	12491	11234	10295	8173	-	3	1325	3.08	34
	16225	15983	15120	14730	12761	10576	8568	5	1560	5.13	42
36	14173	13128	11822	10471	-	-	-	1-1/2	1015	1.61	28
	15114	14353	13243	11988	10514	8772	7444	2	1160	2.11	32
	18020	16740	16186	14342	10549	9510	7865	3	1140	3.05	38
	20849	20157	19368	18978	16490	14118	11362	5	1245	5.12	53
42	18628	17503	15264	12855	11606	-	-	2	930	2.01	29
	22193	20384	18866	17337	15643	13574	-	3	1140	3.13	38
	25960	24822	23667	22374	20839	19521	18043	5	1140	5.07	48
	29490	28518	28186	26569	24926	23934	19623	7-1/2	1140	7.81	58
48	20302	18094	15044	11132	-	-	-	2	655	2.1	29
	27001	25050	22614	18159	12350	-	-	3	745	3.08	32
	29173	27591	25732	23625	21215	17472	-	5	840	5.16	42
	33418	31872	30249	28062	25682	22744	18678	7-1/2	860	7.6	51
	36776	35878	34984	34042	33014	31980	30940	10	1340	10.1	98
54	27348	24097	18041	-	-	-	-	3	530	3.15	29
	34050	31546	28811	24511	18272	-	-	5	640	5.4	39
	42632	40823	38562	36009	29864	23065	-	7-1/2	900	7.55	48
	47064	45427	43602	41604	38006	30622	-	10	860	10.08	52
	49325	48358	47390	45974	42307	37941	34800	15	780	15.71	62
60	35718	32721	24429	19438	-	-	-	3	530	3.11	28
	42487	40061	35933	30065	25302	22050	-	5	640	5.18	35
	48378	45938	43009	38690	35690	30406	-	7-1/2	800	7.59	47
	54617	50622	48428	45938	37363	29993	-	10	845	10.13	53
	57143	54850	52557	50264	47971	42759	35297	15	675	15.61	62

Contact factory for alternate selections if required.

The sound ratings shown are loudness values in fan sones at 5 ft. (1.5m) in a hemispherical free field calculated per AMCA Standard 301 @ free air.

Brake horsepower does not include drive losses.

Values are installation Type A, free inlet fan sone levels.

Performance shown is for types and units without inlet or outlet ducts.



Standard 793

(optional)