

# MODEL STXB-UL762

## UPBLAST BELT DRIVE CENTRIFUGAL ROOF/SIDEWALL EXHAUSTER FOR RESTAURANT AND GENERAL EXHAUST



CENTRIFUGAL ROOF & WALL EXHAUSTERS

### APPLICATION

Isolation of motor and drive components from the air stream and the high velocity vertical air discharge make the model STXB-UL762 ideally suited for the removal of dirty, contaminated and/or high temperature air from processes and buildings. Typical applications include restaurant hoods and similar kitchen exhaust ventilation, fume and smoke removal, laboratory fume hood exhaust and chemical process exhaust.

For grease removal applications the fan must be installed per NFPA 96 and with a 40" discharge height and hinged access base.

### CONSTRUCTION

#### Housing

- Heavy-gauge aluminum for extra strength with prepunched mounting holes.
- Neoprene isolators for reduction of vibration and sound.
- Enclosed, ventilated motor/drive compartment isolates motor and drives from exhaust air.
- Cover easily removed for quick access to motor compartment.
- Water tight conduit tube for easy electrical connection.
- External weather proof disconnect is included on standard models.
- Lifting lugs for easy and safe placement on roof.
- Stainless steel exterior fasteners.

#### Centrifugal Wheel

- All aluminum backward inclined wheel.
- Nonoverloading for safe operation in ducted systems.
- Dynamically balanced for smooth operation.

#### Drives

- Sized for minimum 150% of drive horsepower.
- Machined cast iron adjustable motor pulleys.
- Adjustable base for belt tensioning.
- Nonstatic oil resistant v-belts.

### AMCA SEAL



JencoFan, Div. of Soler & Palau Ventilation Group, certifies that the Models STXB shown herein are licensed to bear the AMCA Seal. The ratings shown are based on test and procedures performed in accordance with AMCA Publication 211 and AMCA Publication 311 and comply with the requirement of the AMCA Certified Ratings Program.



LISTED POWER ROOF VENTILATOR  
UL STANDARD 762

#### Motors

- Single speed open drip-proof are standard.
- All motors are rated for continuous duty.
- 182T and larger motors shipped unmounted for field installation.
- Disconnect switch standard with single speed drip-proof motors.

#### Bearings

- Heavy-duty ball bearing type.
- Prelubricated and permanently sealed.

### DIMENSIONAL DATA

MODEL STXB-RHUL	A	B	C	D	ROOF OPENING	Average Ship Wt. Lbs.
8	18 1/8	29 1/3	28 5/8	24 1/3	13 1/2	123
10	18 1/8	29 1/3	28 5/8	24 1/3	13 1/2	124
12	20 1/8	30 7/8	31 1/3	25 7/8	15 1/2	136
14	20 1/8	30 7/8	31 1/3	25 7/8	15 1/2	138
15	24 1/8	31 3/8	36 1/2	26 5/8	19 1/2	155
16	24 1/8	31 3/8	36 1/2	26 5/8	19 1/2	155

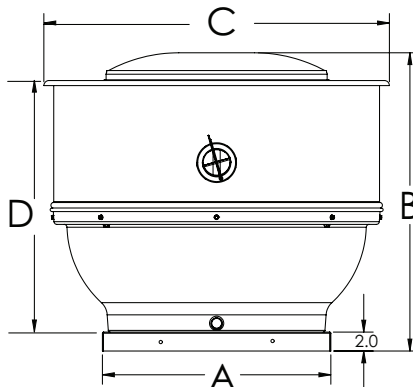

Ship Schedules:	
●	Next Day Shipment From Stock
▲	3 Day Shipment From Stock
◆	10 Day Shipment

Curb Cap adaptors are available to match old style TXB and competitors curb caps. Refer to Optimizer2 for sizes available on Quickship.

### ACCESSORIES

MODEL STXB-RHUL	12" HIGH MOUNTING CURB (1)		18" HIGH MOUNTING CURB	DAMPER (2)		DAMPER MOTOR (LOOSE)	AUTOMATIC BELT TENSIONER (INSTALLED)	HINGED BASE KIT	METAL GREASE BOX
	OD	STOCK NO.	STOCK NO.	OD	STOCK NO.	STOCK NO.	STOCK NO.	STOCK NO.	STOCK NO.
8	16 1/2	711216 ●	721816V ●	12	411012 ●	411611 ●	100069 ●	400252 ●	90005891-A ●
10	16 1/2	711216 ●	721816V ●	12	411012 ●	411611 ●	100069 ●	400252 ●	90005891-A ●
12	18 1/2	711218 ●	721818V ●	14	411014 ●	411611 ●	100070 ●	400252 ●	90005891-A ●
14	18 1/2	711218 ●	721818V ●	14	411014 ●	411611 ●	100070 ●	400252 ●	90005891-A ●
15	22 1/2	711222 ●	721822V ●	18	411018 ●	411611 ●	100070 ●	400252 ●	90005891-A ●
16	22 1/2	711222 ●	721822V ●	18	411018 ●	411611 ●	100070 ●	400252 ●	90005891-A ●

1 - RESTAURANT CURBS MUST BE 18" HIGH MINIMUM PER NFPA-96.

2 - DO NOT USE DAMPER FOR FANS IN GREASE REMOVAL APPLICATIONS PER NFPA 96.

ALL DIMENSIONS IN INCHES, WEIGHTS IN POUNDS. OD IS OUTSIDE DIMENSION OF SQUARE CURB AND DAMPER. DUE TO CONTINUING RESEARCH, Jencofan RESERVES THE RIGHT TO CHANGE SPECIFICATIONS WITHOUT NOTICE.

**Please refer to the General Catalog or contact the Factory for our Full Line of products available on standard shipping schedules.**

**ACCESSORIES CONTINUED**

MODEL STXB	CURB CAP ADAPTOR (replace TXB with STXB using existing curb)	WALL MOUNT ADAPTOR	BIRDSCREEN (3)	GREASE GRABBER	GREASE GRABBER FOR WALL
	STOCK NO.	STOCK NO.	STOCK NO.	STOCK NO.	STOCK NO.
8	CCA1816 ●	400555 ●	400248 ●	708971 ●	708971W ●
10	CCA1816 ●	400555 ●	400248 ●	708971 ●	708971W ●
12	CCA2024 ●	400557 ●	400249 ●	708971 ●	708971W ●
14	N/A	400557 ●	400249 ●	708971 ●	708971W ●
15	N/A	400559 ●	400250 ●	708971 ●	708971W ●
16	N/A	400559 ●	400250 ●	708971 ●	708971W ●

3 - DO NOT USE FOR UL762 APPLICATIONS

<b>MODEL STXB-UL762</b>					<b>Upblast Belt Drive Centrifugal Restaurant Roof Exhauster</b>							Ventilator with Open Drip-proof Motor and Drive Assembly	
Model STXB	Motor Hp	Max. BHp	RPM	Sones @ 1/4 SP	CFM at Static Pressure							115/1/60*	208-230/460/3/60
					0	1/4	1/2	3/4	1	1-1/4	1-1/2	Stock No.	Stock No.
8	1/4	0.13	1,550	9.0	833	714	560	-	-	-	-	STXB08RHULML1S ●	STXB08RHULML3S ▲
	1/4	0.19	1,750	11.5	940	837	720	544	-	-	-	STXB08RHULMM1S ●	STXB08RHULMM3S ▲
	1/4	0.26	1,950	13.5	1047	955	855	732	505	-	-	STXB08RHULMH1S ●	STXB08RHULMH3S ▲
	1/3	0.33	2100	15.0	1128	1041	951	850	705	-	-	STXB08RHULPH1S ●	STXB08RHULPH3S ▲
10	1/4	0.26	1600	12.9	1342	1198	1044	864	-	-	-	STXB10RHULMH1S ●	STXB10RHULMH3S ▲
	1/3	0.37	1800	15.4	1510	1384	1252	1106	934	571	-	STXB10RHULPH1S ●	STXB10RHULPH3S ●
12	1/4	0.26	1450	11.8	1602	1417	1213	958	-	-	-	STXB12RHULMH1S ●	STXB12RHULMH3S ▲
	1/3	0.35	1600	13.8	1768	1599	1431	1221	950	-	-	STXB12RHULPH1S ●	STXB12RHULPH3S ▲
	1/2	0.5	1800	16.5	1989	1840	1698	1520	1331	1086	-	STXB12RHULQH1S ●	STXB12RHULQH3S ●
14	1/4	0.24	1050	9.0	2122	1847	1472	-	-	-	-	STXB14RHULMH1S ●	STXB14RHULMH3S ▲
	1/3	0.36	1200	11.9	2425	2191	1895	1506	-	-	-	STXB14RHULPH1S ●	STXB14RHULPH3S ▲
	1/2	0.52	1350	15.0	2728	2525	2289	1987	-	-	-	STXB14RHULQH1S ●	STXB14RHULQH3S ●
	3/4	0.78	1550	19.1	3132	2960	2763	2537	2269	1947	-	STXB14RHULRH1S ●	STXB14RHULRH3S ●
	1	1.03	1700	22.0	3435	3280	3105	2917	2688	2439	2141	STXB14RHULSH1S ●	STXB14RHULSH3S ●
15	1/4	0.26	1000	8.6	2302	1998	1627	-	-	-	-	STXB15RHULMH1S ●	STXB15RHULMH3S ▲
	1/3	0.34	1100	10.2	2533	2260	1953	1519	-	-	-	STXB15RHULPH1S ●	STXB15RHULPH3S ▲
	1/2	0.5	1250	13.3	2878	2644	2383	2079	1641	-	-	STXB15RHULQH1S ●	STXB15RHULQH3S ●
	3/4	0.78	1450	17.8	3338	3143	2921	2693	2423	2085	-	STXB15RHULRH1S ●	STXB15RHULRH3S ●
	1	1.05	1600	21.0	3684	3510	3311	3107	2895	2638	2325	STXB15RHULSH1S ●	STXB15RHULSH3S ●
16	1/4	0.26	900	9.3	2555	2201	1740	-	-	-	-	STXB16RHULMH1S ●	STXB16RHULMH3S ●
	1/3	0.35	1000	10.9	2839	2524	2152	1511	-	-	-	STXB16RHULPH1S ●	STXB16RHULPH3S ●
	1/2	0.55	1150	14.0	3265	2994	2699	2334	1687	-	-	STXB16RHULQH1S ●	STXB16RHULQH3S ●
	3/4	0.79	1300	17.8	3691	3453	3202	2919	2579	2051	-	STXB16RHULRH1S ●	STXB16RHULRH3S ●
	1	0.99	1400	21.0	3975	3755	3524	3276	2988	2645	1953	STXB16RHULSH1S ●	STXB16RHULSH3S ●

Power ratings (BHP) do not include transmission losses.

Performance certified is for installation type A-free inlet, free outlet. Performance ratings do not include the effects of birdscreen in the airstream.

The sound ratings shown are loudness values in fan sones @ 5' (1.5m) in a hemispherical free field calculated per AMCA Standard 301.

Installation Type A: free inlet hemispherical sone levels.

\*Tri-voltage (115-208-230) is standard on 3/4 through 1 1/2 Hp Single phase motors. Tri-voltage is available for the 1/2 Hp motors. Inquire for price and delivery.

Please refer to the General Catalog or contact the Factory for our Full Line of products available on standard shipping schedules.